



# **GENERAL INFORMATION AND STANDARD SPECIFICATIONS FOR THE INSTALLATION OF WATER MAIN AND SERVICES FOR VEOLIA WATER PENNSYLVANIA INC.**

**ISSUE DATE: JANUARY 2024**

Veolia Water Pennsylvania Inc.  
6310 Allentown Blvd, Suite 104,  
Harrisburg, PA 17112  
888-299-8972



# VEOLIA WATER PENNSYLVANIA INC.

## TABLE OF CONTENTS

2024 REVISIONS.....	5
GENERAL INFORMATION SECTION .....	6
1. INTRODUCTION.....	6
2. DEFINITIONS .....	6
3. QUALIFICATIONS OF CONTRACTORS.....	9
4. CONDITIONS OF WORK.....	10
5. AGENDA & INTERPRETATIONS.....	10
6. LAWS & REGULATIONS.....	10
7. CONTRACT DOCUMENTS .....	10
8. WARRANTEE .....	11
9. DOCUMENTS TO BE KEPT ON THE JOB SITE.....	11
10. CONSTRUCTION MEANS, METHODS, TECHNIQUES, & PROCEDURES.....	11
11. CONTRACTOR'S TOOLS & EQUIPMENT .....	11
12. ROYALTIES & PATENTS.....	11
13. EQUAL OPPORTUNITY CLAUSE.....	12
14. INFORMATION REGARDING EXISTING FACILITIES.....	12
15. RIGHTS OF WAY & EASEMENTS.....	12
16. PRIVATE PROPERTY.....	12
17. RIGHTS OF VARIOUS INTERESTS.....	12
18. UNFORESEEN DIFFICULTIES .....	13
19. WARNING SIGNS & BARRICADES.....	13
20. PROTECTION OF WORK & OWNERS PROPERTY.....	13
21. SANITARY PROVISIONS.....	13
22. PAYMENT FOR WATER USED.....	14
23. PROJECT SCHEDULE .....	14
24. WEEKLY PROGRESS REPORT .....	14
COMPANY PROJECT SECTION.....	15
1. INTRODUCTION.....	15
2. INSTRUCTIONS FOR PREPARING PROPOSAL.....	15
3. INSTRUCTIONS FOR PAYMENT REQUESTS.....	15
4. MATERIALS.....	16

5.	RETURN OF SURPLUS MATERIALS.....	17
6.	SAFETY.....	17
7.	PRECONSTRUCTION CONFERENCE .....	18
8.	PROSECUTION OF THE WORK.....	18
9.	PROGRESS OF CONSTRUCTION .....	19
10.	RESTORATION.....	19
11.	EXAMINATION OF COMPLETED WORK.....	19
12.	USE OF COMPLETED PORTIONS.....	20
13.	EXPLOSIVES.....	20
14.	INTERFERING STRUCTURES & UTILITIES .....	20
15.	PLANS .....	21
16.	FIELD RELOCATION .....	22
17.	PUBLIC SAFETY & CONVENIENCE.....	22
18.	EASEMENTS & PERMITS.....	23
19.	LAND MONUMENTS.....	23
	DEVELOPER PROJECT SECTION.....	24
1.	INTRODUCTION.....	24
2.	INSTRUCTIONS FOR PREPARING PROPOSAL.....	24
3.	SAFETY.....	24
4.	PRECONSTRUCTION CONFERENCE .....	25
5.	PROSECUTION OF THE WORK.....	25
6.	EXAMINATION OF COMPLETED WORK.....	25
7.	USE OF COMPLETED PORTIONS.....	26
8.	PROGRESS OF CONSTRUCTION .....	26
9.	EXPLOSIVES.....	27
10.	INTERFERING STRUCTURES & UTILITIES.....	27
11.	PLANS.....	27
12.	FIELD RELOCATION.....	28
13.	PUBLIC SAFETY & CONVENIENCE.....	28
14.	EASEMENTS & PERMITS .....	29
15.	LAND MONUMENTS.....	29
	INSTALLATION SECTION.....	30
1.	INTRODUCTION.....	30
2.	TRENCH EXCAVATION & BACKFILL.....	30
3.	INSTALLATION OF WATER MAINS.....	37

<b>4. INSTALLATION OF FIRE HYDRANTS .....</b>	<b>48</b>
<b>5. INSTALLATION OF SERVICES.....</b>	<b>51</b>
<b>6. SURFACE REMOVAL &amp; RESTORATION .....</b>	<b>56</b>
<b>PROJECT CLOSE OUT SECTION .....</b>	<b>58</b>
<b>1. INTRODUCTION.....</b>	<b>58</b>
<b>2. BACTERIAL SAMPLING.....</b>	<b>58</b>
<b>3. RECORD OF SERVICE SPREADSHEETS.....</b>	<b>59</b>
<b>4. AS BUILT .....</b>	<b>59</b>
<b>5. PROJECT INSPECTION &amp; PUNCH LIST.....</b>	<b>61</b>
<b>6. BILL OF SALE &amp; MAINTENANCE BOND.....</b>	<b>61</b>
<b>Appendix A - Asbestos Cement Pipe Repair, Removal &amp; Disposal Standard Operating Procedures .....</b>	<b>62</b>
<b>Appendix B - Typical Drawings &amp; Forms.....</b>	<b>Attached, Page 1-34</b>

## **2024 REVISIONS**

### **GENERAL INFORMATION AND STANDARD SPECIFICATIONS FOR THE INSTALLATION OF WATER MAIN AND SERVICES FOR VEOLIA WATER PENNSYLVANIA INC.**

- 1. Qualification of Contractors - Permitted usage of electric ditch pumps, page 9.**
- 2. Trench Excavation & Backfill - Mechanical Tamping - Removal of hydro-hammer usage, page 35.**
- 3. Installation of Water Main- Ductile Iron Pipe - Removal of the use of bronze wedges, page 40.**
- 4. Typical 5/8" X 3/4" Meter with 3/4" PRV Meter Pit detail added; see Appendix, page 20.**
- 5. Typical Water Main Storm, Sewer and Gas Crossings revisions made; see Appendix B, pages 31,32 and 33.**
- 6. Minor changes to GPS directions; see Appendix B, page 48.**

## GENERAL INFORMATION

### 1. **INTRODUCTION**

This document outlines VEOLIA WATER PENNSYLVANIA INC. (Veolia) standard specifications for the installation of water mains, services, and appurtenances. Work will be based upon the policy and procedures outlined in this document and on subsequent forms of proposals. The information presented in this document is for Developer and Company projects. Developer projects are projects completed by a Developer usually involving new water main, services, and appurtenances, where the Contractor is contracted by the Developer to perform water facility installations. Company projects are replacement and new water facility projects where the Contractor is contracted by the Company to install replacement water mains.

### 2. **DEFINITIONS**

The following terms shall have the meanings indicated which shall be applicable to both the singular and plural thereof.

a. Company/Owner

The term `Company` or the term `Owner` shall refer to VEOLIA WATER PENNSYLVANIA INC.

b. Developer

The term "Developer" shall refer to an owner or business installing new water main and appurtenances as part of new construction.

c. Contractor

Firm or corporation executing the Contract with the Company or Developer for the performance of the work.

d. Prequalified Contractor

A firm or corporation that has completed the required prequalification application and has been approved to complete work for VEOLIA WATER PENNSYLVANIA INC. Attendance at the Annual Contractor Meeting is required each year to maintain prequalification status.

e. Superintendent or Foreman

Executive representative of Contractor authorized to receive and fulfill instructions from the Owner.

f. Bidder

Any person, firm, or corporation submitting a bid for The Work described hereunder.

g. Proposal

The offer of a Bidder to perform The Work described by the Contract Documents when made out and submitted on the prescribed form of proposal properly signed.

h. Contract

The contract consists of the information for contractors, the Form of Proposal, the Contract Agreement, the General Conditions, the Specifications, the Plans, Supplemental Specifications and other Supplemental Agreements all as required for the full execution and satisfactory completion of the work.

i. Specifications

The directions, provisions, and requirements contained herein and referred to herein pertaining to the work.

j. Supplemental Specifications

Specific instructions setting forth conditions or requirements peculiar to the project under consideration when said project is not completely covered by the specifications contained herein.

k. Supplemental Agreements

The written agreements executed by the Contractor and the Company covering alterations in the Contract, unforeseen work, and materials incident and necessary to the project.

l. Plans

Company approved maps, standard drawings, work order drawings, and supplemental drawings and sketches which show the locations, character, dimensions and details of the work to be done. The Contractor will be supplied with copies of the Final Official Plans and any Supplemental Specifications for each project. Any alterations affecting the requirements and information given in the Plans and Specifications shall be authorized in writing.

m. The Work

Work required for the complete installation of the water main, services, and appurtenances as described in the specifications and shown on design drawings. Work required for the complete installation of the water main, services, and appurtenances as described in the specifications and shown on design drawings.

n. Short Service

Any service to the side of the street the main is located.

o. Test Hole

Excavation made prior to start of, or during a project for the purpose of locating buried facilities to aid in choice of alignment and grade for proposed pipeline. Excavation made at existing main(s) where a tie-in or a tap is made is not considered a test hole. To include excavation and tamped backfilling of a hole, and temporary and final restoration of surface.

p. Long Service by Excavation

Any service where the main is under the pavement and the method for installation is open cut.

q. Long Service by Trenchless Method

Any service where the main is under the pavement and the method for installation is by trenchless method which may require excavation of a pit.

r. Developer Project

A project funded by a Developer

s. Company Project

A project funded by VEOLIA.

t. Project Schedule

Timeline for complete project including start, milestones, critical path, and completion.

u. Unclassified Excavation

The excavation of all materials encountered, including rock materials, regardless of their nature or the manner in which they are removed. Excavation work (including boring operations) for all Company Projects are unclassified and shall be included in the Contractor's base bid. Change orders will not be paid for rock removal.

v. Weekly Progress Report

Report showing project progress on a weekly basis using VEOLIA provided form.

w. As Built

The general term "As Built" shall consist of 1) GPS data points; to be submitted in real time, prior to backfilling & 2) ROS spreadsheet

When references to the following capitalized abbreviations are made, they refer to specifications, standards, or methods of the respective national association. Abbreviations listed herein, but not mentioned in the Specifications, shall be disregarded.

AASHO	American Association of State Highway Officials	ACI	American Concrete Institute
AISC	American Institute of Steel Construction	AISI	American Iron and Steel Institute
ANSI	American National Standards Institute	ASCE	American Society of Civil Engineers
ASTM	American Society for Testing and Materials	AWWA	American Water Works Association
AWS	American Welding Society		
NEC	National Electrical Code		
NFPA	National Fire Protection Association	UBC	Uniform Building Code

Unless a particular issue is designated, all references to the above specifications, standards, or methods shall, in each instance, be understood to refer to the issue in effect (including all amendments) on the date of the Advertisement for Bids.



### 3. QUALIFICATIONS OF CONTRACTORS

The Contractor shall furnish proof, by listing available equipment and supervisory personnel, that he is capable of pursuing projects for Veolia Water Pennsylvania Inc. without interference from his normal workload not covered by the contract. The Contractor shall also furnish the name and qualifications of the **general superintendent(s)** whose responsibility it shall be to oversee and supervise all work for each VEOLIA WATER PENNSYLVANIA INC. project. The contractor is also required to submit a completed Contractor Safety Prequalification form and all associated information asked for by the form. The Contractor is also required to complete the VEOLIA Contractor Orientation Program. This information is to be supplied to VEOLIA **Annually** upon signing the Annual Agreement for Installation of Water mains and Services.

The Contractor shall further certify that he **owns and will have available on site** the following specialized equipment for use in pursuing work for VEOLIA WATER PENNSYLVANIA INC.:

- (1) One Mueller "D-4" or "B-100" tapping machine (or approved equal) plus accessories for the installation of service taps on mains sized from 2 inches to 24 inches inside diameter.
- (2) One Mueller CC-25 or C1-12 (or equivalent) tapping machine capable of making taps from 2 inches to 12 inches in diameter.
- (3) One auxiliary power-operated pipe saw capable of cutting pipe ranging in size from 4 inches to 24 inches inside diameter.
- (4) Two 1-1/2 inch centrifugal ditch pumps.
- (5) One 2-inch centrifugal ditch pump.
- (6) One 3-inch centrifugal ditch pump.
- (7) One 3-inch diaphragm ditch pump.
- (8) One gasoline engine operated hydraulic test pump capable of developing a minimum pressure of 250 psi.
- (9) One underground-piercing tool (mole) or hydraulic push machine for installing services without street excavation.
- (10) Two-way communication for each working crew.
- (11) Necessary torque, open-end, box and ratchet wrenches for working with mechanical joint and flanged pipe from 4-inch to 16-inch diameter.
- (12) Temporary wing-nut style line plugs, various diameters.
- (13) Backhoe with hydraulic breaker (ram hoe) for the purpose of rock removal.
- (14) One (1) GPS unit per job site.

#### **4. CONDITIONS OF WORK**

The Contractor must make his own determination of the nature of The Work, the general and local conditions which may be encountered and all other matters which may in any way affect The Work. It shall also be the Contractor's responsibility to be thoroughly familiar with the specifications, plans and all other documents pertaining to The Work. Failure to make these determinations or to examine any form, instrument, or document shall not release the Contractor from the obligations to complete The Work as proposed.

#### **5. AGENDA & INTERPRETATIONS**

No interpretation of the meaning of the Specifications or other documents will be made orally.

Every request for such interpretation should be in writing and addressed to Engineering Department, Veolia Water Pennsylvania Inc., 6310 Allentown Blvd., Suite 104, Harrisburg, PA 17112.

Any and all such interpretations and any supplemental instructions will be in the form of written addenda to the specifications. All addenda so issued shall become part of the Contract Documents.

#### **6. LAWS & REGULATIONS**

The Contractor's attention is directed to the fact that all applicable Federal, State Laws, Municipal and County Ordinances, and the rules and regulations of all authorities having jurisdiction over construction of any of The Work covered under The Contract shall apply to the Contract throughout, and they will be deemed to be included in the Contract the same as though herein written out in full.

#### **7. CONTRACT DOCUMENTS**

The intent of the Plans for the various projects, which will be submitted to the Contractor and the Specifications as contained herein, is to describe a complete project, which the Contractor shall undertake to do in full compliance with a Contract Agreement, plans, and Specifications. The Contract Documents comprise the entire agreement between the Company and the Contractor/Developer. They may only be altered as provided for in the General Conditions of the Contract.

Figure dimensions on Plans shall govern over scale dimensions, and detailed drawings shall govern over general drawings. Any work that may reasonably be inferred from the Specifications or Plans as being required to produce the intended result shall be supplied whether or not it is specifically called for. Work, materials, or equipment described in words, which so applied, have a well-known technical or trade meaning shall be deemed to reference such recognized standards. The Contractor assumes full responsibility for having familiarized himself with the nature and extent of the Contract Documents, the Work, locality, and local conditions that may in any manner affect The Work to be done.

**8. WARRANTEE**

The Contractor shall warrant that no verbal agreement or conversation with any officer, agent or employee of the Company, either before, during or after the completion of The Work, has affected or modified any of the terms or obligations herein contained.

**9. DOCUMENTS TO BE KEPT ON THE JOB SITE**

The Contractor shall keep one copy of the Contract Documents, including a plan provided by VEOLIA, a copy of the current year's VEOLIA Specifications and all applicable permits, at each job site, in good order, available to the Company's representatives, and authorized authorities. Original VEOLIA plans must be used for all water main installations. Plans prepared by all others will not be accepted for water main installations.

**10. CONSTRUCTION MEANS, METHODS, TECHNIQUES, & PROCEDURES**

The Contractor shall have the full power and authority to select the means, methods, techniques, and procedures for performing The Work, provided said means, methods, techniques, and procedures are in strict compliance with the requirements of all local, state and federal authorities; are in compliance with these specifications; and are not in conflict with the recommended installation practices of the pipe manufacturer who is the supplier for the pipe to be utilized on the Company's main extension projects. The construction means, methods, techniques, and the procedures utilized shall produce a satisfactory quality of workmanship and shall be adequate to maintain the schedule of progress as required under the provisions of these Specifications.

**11. CONTRACTOR'S TOOLS & EQUIPMENT**

The Contractor's tools and equipment used on The Work shall be furnished in sufficient quantity and of a capacity and type that will safely perform The Work specified, and shall be maintained and used in a manner that will not create a hazard to persons or property, or cause a delay in the progress of The Work. The Owner/Company shall have the right to require the removal and/or replacement of any equipment, which he deems incapable of satisfactory performance.

**12. ROYALTIES & PATENTS**

The Contractor shall pay all royalty and license fees, unless otherwise specified. He shall defend all suits or claims or infringement of any patent rights and shall save the Owner harmless from loss on account thereof.

**13. EQUAL OPPORTUNITY CLAUSE**

“The provisions of Executive Order 11246 of September 24, 1965, and the Rules and Regulations issued therein are hereby incorporated by reference, and the Contractor represents, by acceptance of a Contract to perform The Work, that he will comply with such Executive Order and Rules and Regulations and amendments thereto, to the extent the same are applicable to the contracting and/or subcontracting of services or work hereunder.”

**14. INFORMATION REGARDING EXISTING FACILITIES**

Any information relative to the location of other utilities’ facilities shall be the sole responsibility of the Contractor so specified and defined under PA Act 287 (Pennsylvania One Call Law). Any information relative to the location of the Owner’s Existing Facilities is provided to the contractor as a best possible location based on the Owner’s Records and is not to be interrupted as a definite location. Field adjustments to the planned location of The Work must be coordinated with a representative of the Owner. The Contractor may, at his expense, need to excavate test holes to determine the depth and location of existing water main or other underground facilities.

**15. RIGHTS OF WAY & EASEMENTS**

The various main extension projects and other work are to be constructed in right-of-ways and easements furnished by the Owner. The Contractor shall confine his equipment, the storage of materials and the operation of his workmen to the limits as shown on the Plans or indicated by law, ordinances, permits, or directions of the Owner, and shall not unreasonably encumber the premises with his materials. Any additional land and access thereto, which the Contractor might desire for temporary construction facilities or for storage of materials, shall be provided by the Contractor with no liability to the Owner. The Contractor shall pay all costs involved in acquiring such rights and all clean up shall be made as required by these specifications.

**16. PRIVATE PROPERTY**

The Contractor shall not enter upon private property for any purpose without obtaining permission. The Contractor shall be responsible for the preservation of all public property, trees, and monuments, etc., along and adjacent to the street and/or right-of-way. The Contractor shall use every precaution necessary to prevent damage to pipes, conduits, and other underground structures, and shall protect carefully from disturbance or damage all monuments and property marks until an authorized agent has witnessed or otherwise referenced their location and shall not remove them until directed.

**17. RIGHTS OF VARIOUS INTERESTS**

Wherever work being done by the Owner’s forces is contiguous to The Work of a Contractors project, the respective rights of the various interests involved shall be established by the Owner, to secure the completion of the various portions of The Work in general harmony.

**18. UNFORESEEN DIFFICULTIES**

The Contractor shall protect his work and materials from damage due to the nature of The Work, the elements, carelessness of other Contractors, or from any cause whatever until the completion and acceptance of The Work. All loss or damage arising out of the nature of The Work, or from any unseen obstruction or defects which may be encountered in the prosecution of The Work or from the action of the elements shall be sustained by the Contractor.

**19. WARNING SIGNS & BARRICADES**

The Contractor shall provide adequate signs, barricades and lights, and take all necessary precautions for the protection of The Work and the safety of the public. All warning signs, flashers and barricades shall conform to the applicable provisions of PENNDOT Form 408, "Maintenance, Protection of Traffic on Construction Projects Publication 43" (latest revised issue), and "Temporary Traffic Control Guidelines Publication" 213 (latest revised issue). This applies regardless of where the work is located, in PENNDOT ROW or in any other public or private ROW.

The Contractor shall at all times so conduct his work as to insure the least possible obstruction to traffic and inconvenience to the general public and the residents in the vicinity of The Work, and to insure the protection of persons and property in a manner satisfactory to the Owner. No road or street shall be closed to the public except with the permission of the Owner and proper governmental authority. No driveway or property entrance can be blocked off. The Contractor must provide means for ingress and egress to the property such as steel plates or temporary backfilling of an open work area. Any additional cost as a result of maintaining a property entrance will be the responsibility of the Contractor and will not be applicable to a change work authorization. Temporary provisions shall be made by the Contractor to insure the use of sidewalks and the proper functioning of all gutters, sewer inlets and drainage ditches, which shall not be obstructed except as approved by the Owner.

**20. PROTECTION OF WORK & OWNER'S PROPERTY**

The Contractor shall at all times safely guard the Owner's property and equipment from injury or loss in connection with The Work. Contractor shall at all times safely guard and protect his own work and that of adjacent property (as provided by law and the Contract Documents) from damage. The Contractor shall be responsible for any damage to the Owner's property and equipment, which is a result of the Contractor's negligence.

**21. SANITARY PROVISIONS**

The Contractor shall provide and maintain such sanitary accommodations for the use of his employees and those of his Subcontractors as may be necessary to comply with the requirements and regulations of the local and state Departments of Health and as directed by the Owner.

**22. PAYMENT FOR WATER USED**

The Contractor/Developer shall pay VEOLIA for all water used in the installation of the water system including test water and water loss during the installation process. Water usage will be estimated by the VEOLIA representative dependent on the size of the water system being installed.

**23. PROJECT SCHEDULE**

As part of the bid for Company projects, the Company Contractor shall provide a complete project schedule showing start, milestones, critical path, in-service, substantial completion, and project completion dates.

**24. WEEKLY PROGRESS REPORT**

Company Contractor shall provide a weekly progress report by 12:00 PM Friday at the end of each week. This Report shall also contain the location and scope of anticipated work for the upcoming week. Report shall be submitted on the VEOLIA provided Weekly Progress Report form.

# VEOLIA WATER PENNSYLVANIA INC. COMPANY PROJECT SECTION

## 1. INTRODUCTION

The Owner will furnish all pipes, valves, fittings, and other pipeline appurtenances as may be required plus all service materials and appurtenances to be installed as part of The Work for all Company Projects unless otherwise stated in bid documents or Contract documents. The Contractor shall do all work and furnish all the labor, materials not provided by the Owner, and equipment necessary or required to install various main extension projects and related service installations for VEOLIA WATER PENNSYLVANIA INC.

## 2. INSTRUCTIONS FOR PREPARING PROPOSAL

Payment for completed work shall be at the lump sum price stated for the bid items as established in the Contractor's bid proposal and shall be considered compensation in full for the furnishing of all overhead, labor, materials not provided by the Owner, devices, equipment, and appurtenances included as are necessary to complete the total work for the various projects included in The Work. All work shall be completed in a good, neat and satisfactory manner as shown on the Plans, as described in the Specifications, and as otherwise implied or required to meet the objectives of The Work.

## 3. INSTRUCTIONS FOR PAYMENT REQUESTS

All requests for payment must be submitted to Owner on **The American Institute of Architects (AIA) Document G702**. Payment request must include the **VEOLIA Waiver and Release of Lien from Schedule C of the VEOLIA Annual Agreement**. Owner payment terms are Contract specific. No payment for work outside of the project scope will be made to the Owner without prior approval through the written change request process. The Change Request form is included in Appendix B.

#### **4. MATERIALS**

The Owner shall furnish all pipe, valves, fittings, sleeves, fire hydrants and appurtenances, and such other pipeline materials as may be required plus all service materials including corporation stops, tapping sleeves and valves, pipe, curb stops, etc., as required for service installation. The fact that the Owner is to furnish material is conclusive evidence of its acceptability for the purpose intended and the Contractor may continue to use it until otherwise directed.

The Contractor's responsibility for material furnished by the Owner shall begin upon the Contractor's acceptance of the material at the point of delivery to him. The Contractor shall examine all such materials and the Contractor can reject any material found to be defective in manufacture and/or otherwise damaged at the time and place of delivery to him. The Owner will replace said rejected materials. Materials furnished by the Owner and accepted by the Contractor, which are found damaged after acceptance by the Contractor, shall be replaced by the Contractor at his own expense and he shall be responsible for the disposal of said damaged materials. Materials, which are delivered directly to a job site by the material manufacturer or supplier shall be accepted or rejected by the Contractor at that time. Failure by the Contractor to have a responsible party present for acceptance or rejection of the materials shall not relieve the Contractor of his responsibility for materials delivered to the job site. The Contractor's failure to accept or reject materials delivered to a job site shall mean he accepts as sound all materials so delivered.

All materials as provided by the Owner shall be furnished to the Contractor at the Owner's pipe storage yard or shop facility and shall be transported to the job site by the Contractor at his expense, except where delivery of pipe or other material to the job site is by the material manufacturer. The pick-up of materials at the Owner's pipe storage yard or shop facility shall be coordinated by the Contractor with the Owner's representative and shall not be on an "urgent" or "emergency" basis. The Contractor shall be responsible for providing all equipment necessary for the loading and unloading of materials. The Contractor shall not pick up any material unless it is properly charged to him and he shall be responsible for any material loss or damage after receipt of materials.

Any materials delivered to a job site are the responsibility of the Contractor. Contractor must deliver the packing slip & Bill of Lading for all materials delivered to the job site to Owner within 24 hours of delivery. By signing the receiver slip, the Contractor assumes responsibility for all materials listed on the receiver slip.



## **5. RETURN OF SURPLUS MATERIALS**

Upon completion of a project and at his expense, the Contractor shall deliver to such delivery points, storage lots, or warehouses as designated by the Owner, all materials as furnished by the Owner and not used in The Work, regardless of location of said materials at that time. Prior to acceptance, the Owner's personnel shall inspect materials so returned by the Contractor. The Owner will not accept any material, which has been damaged, and the Contractor shall be responsible for the disposal of such damaged materials. The Owner's personnel shall properly record and document the returned material once accepted. The Contractor shall compensate the Owner or replace any lost or damaged materials.

Material must be returned prior to Retainage release.

## **6. SAFETY**

The Contractor will be solely and completely responsible for conditions of the job sites, including safety of all persons and property during performance of The Work. This requirement will apply continuously and not be limited to normal working hours. Safety provisions shall conform to all applicable federal, state, county, and local laws, ordinances and codes. A health and safety plan must be produced by the Contractor for the performance of The Work and shall be provided to the Owner and kept on site at all times for the review of the Owner, any inspector or applicable health and safety enforcement agency to review.

The Contractor shall also comply with all applicable U.S. Department of Labor (e.g. Construction Safety Act) and Occupational Safety and Health Administration (e.g. Occupational Health and Safety Act) regulations and the Manual of Accident Prevention in Construction published by the Associated General Contractors of America, except where these are in conflict with State Laws, in which case the more stringent requirement shall be followed.

The Contractor shall maintain at the job site all articles necessary for giving first aid to the injured, and shall establish the procedures for the immediate removal to a hospital or a doctor's care of persons (including employees) who may be injured on the job site.

The duty of the Owner to conduct construction reviews of the Contractor's performance is not intended to include review of the adequacy of the contractor's safety measures in, on, or near the construction sites. However, the Owner reserves the right to shut down a project when in the Owner's or Owner's Representative's opinion a gross negligent safety condition(s) is/are present that threatens the safety of the Owner and/or his employees or representative, the public, or the contractor's personnel. The Contractor is responsible for determining and providing solution(s) to correct the unsafe condition(s). The Owner will not provide or recommend corrective actions. Once the situation, in the Owners opinion, has been satisfactorily corrected, the Owner will allow the Contractor to continue The Work.

If death or serious injuries or serious damages are caused, the accident shall be reported immediately by telephone or messenger to the Owner. In addition, the contractor must promptly report in writing to the Owner all accidents whatsoever arising out of or in connection with the performance of The Work whether on, or adjacent to, the sites, giving full details and statements of witnesses.

If any claim is made by anyone against the Contractor on account of any accident, the Contractor shall promptly report the facts in writing to the Owner giving full details of the claim.

## **7. PRECONSTRUCTION CONFERENCE**

Before starting The Work, a Preconstruction Conference will be held to review scheduling of The Work, evaluation of shut downs/planned tie-ins, and to establish a working understanding between the parties as to The Work. At a minimum, the Owner, a representative of the Owner's Inspection Firm, and the Superintendent or Foreman from the Contractor shall be present at the preconstruction conference.

## **8. PROSECUTION OF THE WORK**

It is expressly understood and agreed that the time of beginning, rate of progress, and times of completion of The Work are of the utmost importance. The Contractor shall perform the construction of work with due diligence and at such a rate and in such a manner as, in the opinion of the Owner, is necessary for completion within a reasonable time. The Contractor shall arrange his work and dispose of materials so as to insure the least possible interference and inconvenience to the land owners on or beside whose property the pipelines are being constructed, or to the public where the pipelines lie in or near a public thoroughfare. Contractor shall employ only such number of construction crews as are reasonably necessary to construct said pipelines. If the Contractor desires to carry on work at night or outside the regular hours, he shall contact the proper governing body to gain permission to work outside the regular hours. He shall also give timely notice to the Owner to allow satisfactory arrangements to be made for inspecting The Work.

## **9. PROGRESS OF CONSTRUCTION**

It is understood and agreed upon that the progress of The Work shall proceed in a systematic manner so the minimum of inconvenience will result to the public in the course of construction. It is therefore necessary that the Contractor confine his operations to the smallest work crew feasible.

Complete backfill and clean up shall be accomplished at the end of each day and/or after each section of the pipe has been inspected and approved.

Clean up of all construction debris, excess excavation, excess materials, and complete restoration of all fences, mailboxes, ditches, culverts, signposts, and similar items shall be completed immediately following the final backfilling of the line and testing of the main. The Contractor shall stockpile the excavated trench material to do the least damage to adjacent areas or fences, regardless of whether these are on private property or public right-of-way. All excavated materials shall be removed from adjacent areas, and these surfaces shall be left in a condition equivalent to their original surface and free from all rocks, gravel, boulders or other foreign material at the end of each workday.

It is understood and agreed that the Contractor shall provide all labor and equipment necessary to grade and maintain in a reasonable condition all streets on which water main construction has been accomplished until surface repair has been completed.

## **10. RESTORATION**

All temporary and final restoration shall be completed in a timely manner to an as-good or better than pre-construction condition.

Temporary Restoration: Temporary restoration shall be completed daily for all water facility work completed each day. Temporary restoration shall provide a level at grade finish with no trip hazards. No trench or holes shall be left open when Contractor is not on site. If a hole or trench must be left open for an extended period Contractor shall provide steel plating and OSHA approved barriers to provide adequate protection from unauthorized persons from entering opening.

Final Restoration: Upon completion of the project installation, contractor shall contact VEOLIA to schedule a site visit. The site visit will confirm the required final restoration scope of work.

## **11. EXAMINATION OF COMPLETED WORK**

### **Pipe Bedding/Cover Verification:**

Upon completion of the project and at any time before acceptance of The Work by the Owner, the Contractor is required to uncover the pipe at two locations randomly chosen by the Owner's Inspector – the purpose being to verify the 2A modified pipe cover requirement. Possible consequences to a violation of the pipe cover requirement include an extension of the maintenance bond duration and/or Contractor loss of pre-qualified status. Cost of uncovering such work shall be borne by the Contractor, whether or not the depth of pipe cover is found acceptable.

### **Other Requests to Uncover Installed Pipe:**

At any time before acceptance of The Work by the Owner, the Owner's Representative may request that the Contractor remove or uncover such portions of the finished work as may be directed. After examination, the Contractor shall restore said portions of The Work to the standards required by the Specifications. If The Work thus exposed or examined proves to be in accordance with the Specifications, the costs to uncover and restore The Work will be paid for by the Owner. However, should The Work so exposed or examined prove to be not in accordance with the Specifications, the costs to uncover and restore The Work to the standards required by the Specifications shall be at the Contractor's expense. Any work performed by the Contractor without sufficient notice to the Owner that eliminates an opportunity for inspection by the Owners Representative will be uncovered at the Contractor's expense for examination by the Owner. Cost of uncovering such work shall be borne by the Contractor, whether or not The Work is found acceptable. The Work shall also be subject to inspection by appropriate governmental inspectors at all times.

### **12. USE OF COMPLETED PORTIONS**

The Owner shall have the right to take possession of and use any completed or partially completed portions of The Work. Such use shall not be considered as final acceptance of any portion of The Work, nor shall such use be considered as cause for an extension of Contract completion time unless authorized by a change order issued by the Owner.

### **13. EXPLOSIVES**

Use of explosives is prohibited for water main installation unless authorized by VEOLIA, in writing.

### **14. INTERFERING STRUCTURES & UTILITIES**

The Contractor shall exercise all possible caution to prevent damage to existing structures and utilities whether aboveground or underground. Whenever possible, the Owner will attempt to locate its proposed water main extension so as to provide a minimum of conflict with existing structures and utilities. While the location of existing structures and utilities will be based upon the best information available, the completeness and accuracy of said information cannot be guaranteed, and it is provided simply as a guide to possible difficulties. The Contractor shall be required to notify all utility offices concerned at least forty-eight (48) hours in advance of construction operations in which a utility's facilities may be involved. This notification does not alleviate or replace the Contractor's responsibility to contact PA One Call as required by law. It is recommended that these utilities be contacted to attend the preconstruction conference. This shall include but is not limited to sanitary and storm sewers, telephone, cable, electric and gas.

**It shall be the responsibility of the Contractor to locate and expose all existing underground structures and utilities in advance of the trench excavation including Owners facilities.** In the event that any structures and/or utilities are

damaged by The Work, the contractor shall immediately contact their VEOLIA representative to disclose details of the event. Where applicable, contractor and VEOLIA representative shall file Alleged Violation Report(s) (AVR) in accordance with applicable PA One Call law and acceptable standards. Existing, damaged utilities shall be repaired or replaced in accordance with applicable AVR guidelines and requirements. Where applicable, such repair or replacement shall be accomplished at the Contractor's expense without additional compensation from the Owner.

The Contractor shall, with the permission of the owner of the following, remove and replace such small miscellaneous structures as fences, catch basins, drain pipe, culverts, mailboxes, and signposts at his own expense without additional compensation from the Owner. The Contractor shall replace these structures in a condition as good as or better than their original condition.

If power poles, telephone poles, guy wires, or anchors are encountered that conflict with the proposed work, the Contractor shall notify the Owner at least seven (7) days in advance of construction to allow for discussion with the utility company for protection or relocation of the structures. The Contractor shall arrange protection of the interfering facility with the appropriate utility company.

The Contractor shall remove, protect and replace all drainage ways, all drainage structures, or other improvements and similar items located along the proposed water mains at his own expense without additional compensation from the Owner. Replacement shall be in a manner and in a condition at least equivalent to the original condition.

If the Contractor encounters existing structures, which will prevent the construction of the pipeline, he shall notify the Owner before continuing with the construction in order that the Owner may make such field revisions as necessary to avoid conflict with the existing structures. The cost of waiting or "down" time during such field revision shall be at no additional cost to the Owner. If the Contractor shall fail to so notify the Owner when an existing structure is encountered, but shall proceed with the construction despite this interference, he shall do so at his own risk. In particular, when the location of the new construction, as shown on the Plans, will prohibit the restoration of existing structures to their original conditions, he shall notify the Owner so relocation may be made to avoid the conflict.

## **15. PLANS**

The Contractor will be provided with Plans furnished by the Owner for each project. These Plans will show the locations of the proposed facilities and denote thereon all fittings, valves, and other pipeline appurtenances as may be required. The Contractor is required to keep a copy of the Plans on site at all times during The Work for review by the Owner, Owners Inspector or any governing agent.

## **16. FIELD RELOCATION**

During the progress of construction, it is possible that minor relocations may be necessary. Such relocations shall be made only by direction of the Owners Representative. Unforeseen obstructions encountered as a result of such relocations will not be subject to claims for additional compensation by the Contractor to any greater extent than would have been the case had the obstruction been encountered along or in the original location.

## **17. PUBLIC SAFETY & CONVENIENCE**

The Contractor shall comply with all rules and regulations of the Local, County and State authorities regarding the closing of public streets or highways to the use of public traffic. No road shall be closed by the Contractor to the public except by express permission of the Owner and the governing authority. Traffic must be kept open on roads and streets where a detour is impossible. The Contractor shall, at all times, conduct his work so as to assure the least possible obstruction to traffic and normal commercial pursuits. All obstructions within traveled roadways shall be protected by approved signs, barricades and lights where necessary or ordered by the Owner or the governing authority for the safety of the traveling public. The convenience of the general public and the protection of persons and property are the prime importance and shall be provided for by the Contractor in an adequate and satisfactory manner.

The Contractor shall use every reasonable precaution to safeguard the persons and property of the traveling public. Failure of the Owner to notify the Contractor to maintain barricades, barriers, lights, flares, danger signals, or watchman shall not relieve the contractor from his responsibility. All barricades and obstructions shall be protected at night by signal lights, which shall be suitably distributed across the roadway or alleyway and kept burning from sunset to sunrise.

Whenever the Contractor's operations create a hazardous condition, he shall furnish flagmen and guards as necessary or as ordered by the Owner or the governing authority to give adequate warning to the public of any dangerous conditions to be encountered. He shall furnish, erect, and maintain approved fences, barricades, lights, signs, and any other devices that may be equipped with safety wearing apparel and a flag, which shall be kept clean and in good repair.

The Contractor will be required to confine construction operations within the dedicated right-of-ways or within areas for which construction easements have been obtained unless he has made special arrangements with the affected property owners in advance. The Contractor will be required to protect stored materials, cultivated crops and trees, and other items located adjacent to the pipe lines. During all construction operations, the Contractor shall construct and maintain such facilities as may be required to provide access by all property owners to their property. No person shall be cut off from access to his residence or place of business unless the Contractor has made special arrangements with the affected persons. The Contractor shall provide for control at all times for livestock through farm areas by whatever means necessary, including temporary fencing.

## **18. EASEMENTS & PERMITS**

Portions of the project may be located on private property. The Owner will obtain easements and permits. Easements shall provide for the use of property for construction purposes to the extent indicated on the easements. Copies of these easements and permits will be available at the offices of the Owner for inspection by the Contractor. The Contractor shall confine his construction operations to within the easement limits or street and alley right-of-way limits or make special arrangements with the property owners for the additional area required. Any damage to private property, either inside or outside the limits of the easements provided by the Owner shall be the responsibility of the Contractor.

## **19. LAND MONUMENTS**

The Contractor shall preserve existing City, County, State, Federal, and private land monuments where possible. When these monuments cannot be preserved, the Contractor shall notify the Owner at least forty-eight (48) hours in advance of the proposed construction in order that the Owner will have ample opportunity to reference these monuments for later replacement.

# VEOLIA WATER PENNSYLVANIA INC.

## DEVELOPER PROJECT SECTION

### **1. INTRODUCTION**

The Developer shall furnish all pipes, valves, fittings, sleeves, fire hydrants, casing pipe and appurtenances, and such other pipeline materials as may be required plus all service materials including corporation stops, tapping sleeves and valves, pipe, curb stops, etc., as required for service installation. The material will be inspected and approved before installation by the Owner's representative. The inspection will be scheduled with the Company's representative by the Developer or Developer's Contractor.

### **2. INSTRUCTIONS FOR PREPARING PROPOSAL**

Payment for Developer projects will be at the discretion of the Developer. The Agreement for water main installation will be between the Developer and the Contractor. VEOLIA requires a Proposed Cost Summary Breakout and a Final Cost Summary Breakout using VEOLIA provided forms for all Developer projects.

All costs that apply to specific bid items shall be included under that item for both Cost Summary and Final Cost Summary Breakouts. All additional costs, such as testing and other incidental operations, profit, overhead cost including the cost of supervision, site mobilization, insurance, taxes, equipment not a permanent part of the job, and other incidental items shall be distributed proportionally throughout all items.

### **3. SAFETY**

The Contractor will be solely and completely responsible for conditions of the job sites, including safety of all persons and property during performance of The Work. This requirement will apply continuously and not be limited to normal working hours. Safety provisions shall conform to all applicable state, county, and local laws, ordinances and codes. A health and safety plan must be produced by the Contractor for the performance of The Work and shall be provided to the Owner and kept on site at all times for the review of the Owner or any applicable health and safety enforcement agency to review.

The Contractor shall also comply with all applicable U.S. Department of Labor (e.g. Construction Safety Act) and Occupational Safety and Health Administration (e.g. Occupational Health and Safety Act) regulations and the Manual of Accident Prevention in Construction published by the Associated General Contractors of America, except where these are in conflict with State Laws, in which case the more stringent requirement shall be followed.

The Contractor shall maintain at the job site all articles necessary for giving first aid to the injured, and shall establish the procedures for the immediate removal to a hospital or a doctor's care of persons (including employees) who may be injured on the job site.



The duty of the Owner to conduct construction reviews of the Contractor's performance is not intended to include review of the adequacy of the contractor's safety measures in, on, or near the construction sites.

If death or serious injuries or serious damages are caused, the accident shall be reported immediately by telephone or messenger to the Owner's Representative. In addition, the Contractor must promptly report in writing to the Owner all accidents whatsoever arising out of or in connection with the performance of The Work whether on, or adjacent to, the sites, giving full details and statements of witnesses.

If any claim is made by anyone against the Contractor on account of any accident, the contractor shall promptly report the facts in writing to the Owner's Representative giving full details of the claim.

#### **4. PRECONSTRUCTION CONFERENCE**

Before starting The Work, a Preconstruction Conference will be held to inspect material, to review scheduling of The Work, to establish procedures for processing applications for payment and to establish a working understanding between the parties as to The Work. At a minimum, the Owner, a representative of the Owner's Inspection Firm, the Superintendent or Foreman from the Contractor and a representative of the Developer shall be present at the preconstruction conference. No construction of water main or appurtenances will be permitted until all rough grading of the area in which the facilities are to be located is complete. For the purposes of this section, rough grading shall be considered to be the designed finish grade plus or minus eight inches (8").

#### **5. PROSECUTION OF THE WORK**

It is expressly understood and agreed that the time of beginning, rate of progress, and times of completion of The Work are of the utmost importance. The Contractor shall perform the construction of work with due diligence and at such a rate and in such a manner as, in the opinion of the Owner, is necessary for completion within a reasonable time. The Contractor shall arrange his work and dispose of materials so as to insure the least possible interference and inconvenience to the land owners on or beside whose property the pipelines are being constructed, or to the public where the pipelines lie in or near a public thoroughfare. Contractor shall employ only such number of construction crews as are reasonably necessary to construct said pipelines. If the Contractor desires to carry on work at night or outside the regular hours, he shall give timely notice to the Owner or allow satisfactory arrangements to be made for inspecting the work in progress.

#### **6. EXAMINATION OF COMPLETED WORK**

##### **Pipe Bedding/Cover Verification:**

Upon completion of the project and at any time before acceptance of The Work by the Owner, the Contractor is required to uncover the pipe at two locations randomly chosen by the field inspector – the purpose being to verify the 2A modified pipe cover requirement.

Possible consequences to a violation of the pipe cover requirement include an extension of the maintenance bond duration and/or Contractor loss of pre-qualified

status. Cost of uncovering such work shall be borne by the Contractor, whether or not the depth of pipe cover is found acceptable.

**Other Requests to Uncover Installed Pipe:**

At any time before acceptance of The Work by the Owner, the Owner may request that the Contractor remove or uncover such portions of the finished work as may be directed. After examination, the Contractor shall restore said portions of The Work to the standards required by the Specifications. If The Work thus exposed or examined proves to be in accordance with the Specifications, the costs to uncover and restore The Work will be paid for by the Owner. However, should The Work so exposed or examined prove to be not in accordance with the Specifications, the costs to uncover and restore the work to the standards required by the Specifications shall be at the Contractor's expense. Any work performed by the Contractor without sufficient notice to the Owner that eliminates an opportunity for inspection by the Owner or his representative will be uncovered at the Contractor's expense for examination by the Owner. Cost of uncovering such work shall be borne by the Contractor, whether or not The Work is found acceptable. The Work shall also be subject to inspection by appropriate governmental inspectors at all times.

**7. USE OF COMPLETED PORTIONS**

The Owner shall have the right to take possession of and use any completed or partially completed portions of The Work. Such use shall not be considered as final acceptance of any portion of The Work.

**8. PROGRESS OF CONSTRUCTION**

It is understood and agreed upon that the progress of The Work shall proceed in a systematic manner so the minimum of inconvenience will result to the public in the course of construction. It is therefore necessary that the Contractor confine his operations to the smallest work crew feasible. Complete backfill and clean up shall be accomplished at the end of each day and/or after each section of the pipe has been inspected and approved.

The Owner reserves the right to withhold line and grade on any water line when, in his opinion, excessive trench is being opened ahead of the pipe laying, backfilling behind the pipe laying is not proceeding satisfactorily, clean-up and restoration of all physical properties are lagging and pipe testing, as outlined herein, is not satisfactory.

Clean-up of all construction debris, excess excavation, excess materials, and complete restoration of all fences, mailboxes, ditches, culverts, signposts, and similar items shall be completed immediately following the installation of the water main. The Contractor shall stockpile the excavated trench material so as to do the least damage to adjacent areas, regardless of whether these are on private property or public right-of-way. All excavated materials shall be removed from adjacent areas, and these surfaces shall be left in a condition equivalent to their original surface and free from all rocks, gravel, boulders or other foreign material at the end of each work day.

It is understood and agreed upon that the Contractor shall provide all labor and equipment necessary to grade and maintain in a reasonable condition all streets on

which water main construction has been accomplished until surface repair has been completed.

## **9. EXPLOSIVES**

Use of explosives is prohibited for water main installation unless authorized by VEOLIA, in writing.

## **10. INTERFERING STRUCTURES & UTILITIES**

The Contractor shall exercise all possible caution to prevent damage to existing structures and utilities whether aboveground or underground. Whenever possible, the Owner will attempt to locate its proposed water main extension so as to provide a minimum of conflict with existing structures and utilities. While the location of existing structures and utilities will be based upon the best information available, the completeness and accuracy of said information cannot be guaranteed, and it is provided simply as a guide to possible difficulties.

It shall be the responsibility of the Contractor to locate and expose all existing underground structures and utilities in advance of the trench excavation including Owner's facilities. Any structures or utilities damaged by The Work shall be repaired or replaced in condition equal to or better than the condition prior to the damage.

The Contractor shall, with the permission of the owner of the following, remove and replace such small miscellaneous structures as fences, catch basins, drain pipe, culverts, mailboxes, and signposts. The Contractor shall replace these structures in a condition as good as or better than their original condition.

If interfering power poles, telephone poles, guy wires, or anchors are encountered, the Contractor shall notify the Owner seven (7) days prior to construction to allow for discussion with the utility company for protection or relocation of the structures.

The Contractor shall remove, protect and replace all drainage ways, all drainage structures, or other improvements and similar items located along the proposed water mains. Replacement shall be in a manner and in a condition as good as or better than their original condition.

If the Contractor encounters existing structures, which will prevent the construction of the pipeline, he shall notify the Owner before continuing with the construction in order that the Owner may make such field revisions as necessary to avoid conflict with the existing structures. If the Contractor shall fail to so notify the Owner when an existing structure is encountered, but shall proceed with the construction despite this interference, he shall do so at his own risk. In particular, when the location of the new construction, as shown on the Plans, will prohibit the restoration of existing structures to their original conditions, he shall notify the Owner so relocation may be made to avoid the conflict.

## **11. PLANS**

The Contractor will be provided with Plans furnished by the Owner for the project. These Plans will show the locations of the proposed facilities and denote thereon all fittings, valves, and other pipeline appurtenances as may be required. No other plan shall be used for The Work.

The plan provided by the Owner will display the Owner's Logo. The plans must be labeled with the most recent revision date. Construction of The Work by the use of any other plan will result in the removal of the installed facilities at the Contractors cost and reinstallation per the Owners Plans.

## **12. FIELD RELOCATION**

During the progress of construction, it is possible that minor relocations may be necessary. Such relocations shall be made only by direction of the Owner or his representative. Unforeseen obstructions encountered as a result of such relocations will not be subject to claims for compensation by the Contractor.

## **13. PUBLIC SAFETY & CONVENIENCE**

The Contractor shall comply with all rules and regulations of the Local, County and State authorities regarding the closing of public streets or highways to the use of public traffic. No road shall be closed by the Contractor to the public except by express permission of the governing authority and the Owner. Traffic must be kept open on roads and streets where a detour is impossible. The Contractor shall, at all times, conduct his work so as to assure the least possible obstruction to traffic and normal commercial pursuits. All obstructions within traveled roadways shall be protected by approved signs, barricades and lights where necessary or ordered by the Owner or his representative for the safety of the traveling public. The convenience of the general public and the protection of persons and property are the prime importance and shall be provided for by the Contractor in an adequate and satisfactory manner.

The Contractor shall use every reasonable precaution to safeguard the persons and property of the traveling public. Failure of the Owner to notify the Contractor to maintain barricades, barriers, lights, flares, danger signals, or watchman shall not relieve the contractor from his responsibility. All barricades and obstructions shall be protected at night by signal lights, which shall be suitably distributed across the roadway or alleyway and kept burning from sunset to sunrise.

Whenever the Contractor's operations create a hazardous condition, he shall furnish flagmen and guards as necessary or as ordered by the Owner to give adequate warning to the public of any dangerous conditions to be encountered. He shall furnish, erect, and maintain approved fences, barricades, lights, signs, and any other devices that may be equipped with safety wearing apparel and a flag which shall be kept clean and in good repair.

The Contractor will be required to confine construction operations within the dedicated right-of-ways or within areas for which construction easements have been obtained unless he has made special arrangements with the affected property owners in advance. The Contractor will be required to protect stored materials, cultivated crops and trees, and other items located adjacent to the pipe lines. During all construction operations, the Contractor shall construct and maintain such facilities as may be required to provide access by all property owners to their property. No person shall be cut off from access to his residence or place of business unless the Contractor has made special arrangements with the affected persons. The Contractor shall provide for control at all times for livestock through farm areas by whatever means necessary, including temporary fencing.

#### **14. EASEMENTS & PERMITS**

Portions of the project may be located on private property. The Owner or Developer will obtain easements and permits. Easements shall provide for the use of property for construction purposes to the extent indicated on the easements. Copies of these easements and permits which were obtained by the Owner will be available at the offices of the Owner for inspection by the Contractor. The Contractor shall confine his construction operations to within the easement limits or street and alley right-of-way limits or make special arrangements with the property owners for the additional area required. Any damage to private property, either inside or outside the limits of the easements provided by the Owner or Developer shall be the responsibility of the Contractor.

#### **15. LAND MONUMENTS**

The Contractor shall preserve existing City, County, State and Federal land monuments where possible. When these monuments cannot be preserved, it is the Contractor's responsibility to reference these monuments for later replacement.

# VEOLIA WATER PENNSYLVANIA INC.

## INSTALLATION SECTION

### 1. INTRODUCTION

Each Section hereinafter is divided, where applicable, into Sections and consisting of: A. Scope; B. Materials; C. Workmanship; and D. Measurement and Payment. This method is employed to facilitate the Contractor in preparing his proposal and in following the Specifications during construction.

### 2. TRENCH EXCAVATION & BACKFILL

#### A. Scope

This section covers the work necessary for the trench excavation and backfill, including but not limited to clearing the right-of-way; protection of private property during construction; disposal of cleared materials; excavation of the trench for pipe and appurtenances; foundation stabilization; trench backfill of the types required; removal, replacement, and rehabilitation of all drainage, waterways, or other features moved or damaged during the construction; removal of all obstructions; removal of existing pavement; locating and protecting existing utilities; the maintenance of access to public thoroughfares and to private property; the maintenance of adequate barricades, lights and warning signs for the protection of the public on city streets, alleys, public highways, country roads and private drives; shoring, cribbing, bracing, and dewatering as may be required; hauling and disposal of waste excavation, including temporary hauling and disposal of soils, which cannot be accommodated within the designed right-of-way; repair of public and private property damaged during construction; final cleanup of the construction area; and all miscellaneous items of work required to complete the construction as specified hereunder.

#### B. Materials

Unclassified Excavation – is defined as the excavation of all materials encountered, including rock materials, regardless of their nature or the manner in which they are removed. Excavation work (including boring operations) for all Company Projects are unclassified and shall be included in the Contractor's base bid. Change orders will not be paid for unclassified excavations.

Rock Excavation on Developer Projects should be included in the final cost of the water main installation and will be paid for by the Developer.

1. Pipe Bedding Material - Pipe bedding material shall be 2A modified stone.

2. Select Backfill Material – Select backfill material shall be less than 1” diameter and shall be free of all deleterious materials.

### C. Workmanship

General - All trench excavation and backfill shall conform to the Specifications of any controlling regulating agency under which the work is being performed. Any item of trench excavation and backfill not covered by the Specifications of a regulating agency or by these Specifications shall conform to ANSI/AWWA Specifications C600-99 (Installation of Ductile-Iron Water Mains and Their Appurtenances) and C605-94 (Underground Installation of Polyvinyl Chloride (PVC) Pressure Pipe and Fittings for Water).

Clearing the Right-of-Way- Where clearing of the right-of-way is necessary, it shall be completed prior to the start of the trenching. Brush shall be cut as near to the surface of the ground as practicable and removed to an approved disposal site. The Contractor shall observe all Federal and State laws relating to fire permits and local regulations relating to burning materials. Under no conditions shall excavated materials be permitted to cover brush, stumps, or woody material prior to clearing and disposal of it. Burying of brush, woody material, stumps, and clearing waste materials is not permitted.

Obstructions- This item shall refer to obstructions, which may be removed and do not require replacement. Obstructions to the construction of the trenches such as, but not limited to; tree roots, stumps, abandoned concrete obstructions and debris of all types shall be removed by the Contractor. Cost of removal of obstructions shall be included in the cost of the water main installation. Contractor is responsible for including the cost to remove obstructions in the original bid.

Alignment and Grade- Trench excavation shall be to the required alignment as shown on the plans or as directed by the Owner. Grade for the top of the pipe for all water mains shall be four (4) feet below finished street grade or finished ground elevation. Any deviation to this pipe depth requirement must be approved in advance by the Owner.

**Trench Width** – For all pipe installations, the width of the trench shall be the pipe diameter plus twenty four (24) inches at the bottom of the trench. Trench widths shown in the following table may be used as a guide. Where embedment compaction is required, the trench shall be wide enough to accommodate the compaction equipment. Unless approved by the Owner, the clear width of the trench at the top of the pipe should not exceed the pipe outside diameter plus thirty (30) inches. When required to meet applicable safety requirements, trenches shall be wider to permit the placement of timber supports, sheeting, bracing, and appurtenances. No added payment will be given if the Contractor wishes to oversize the trench excavations.

Nominal Pipe Size	Trench Width
<i>in.</i>	<i>in.</i>
3 and 4	28
6	30
8	32
10	34
12	36
14	38
16	40
18	42
20	44
24	48

**Foundation** - The pipe shall be laid on 6” of 2A modified stone. Any part of the trench excavated below grade shall be backfilled to grade with thoroughly compacted 2A modified stone. Where the bottom of the trench encounters unstable conditions due to ground water, and in other areas as directed by the Owner, excavation shall extend to an additional depth below the line of the pipe bell and then be backfilled and tamped with 2A modified stone to form a cradle for the pipe. For the installation of ductile-iron pipe, when the soil is found to include ashes, cinders, refuse, organic material, or other unsuitable material, this material shall be removed to a minimum of at least six (6) inches below the bottom of the pipe or to a depth otherwise required by these specifications. The removed material shall be replaced with 2A modified stone. When these potentially corrosive materials are encountered, polyethylene encasement shall be used to protect the ductile-iron pipe as specified in ANSI/AWWA C600-99 (AWWA Standard for Installation of Ductile iron water mains and their appurtenances).



Rock Excavation - For PVC pipe, where the bottom of the trench encounters ledge rock, boulders, cobbles and/or large stones, said rock should be removed to provide at least twelve (12) inches of clearance to each side of and below all pipe and accessories. For ductile-iron pipe, all rock shall be removed to provide a clearance below and on each side of all pipe, valves and fittings of at least twelve (12) inches for nominal pipe sizes twenty-four (24) inches or smaller and eighteen (18) inches for nominal pipe sizes thirty (30) inches and larger. Excavations below subgrade in rock shall be backfilled to subgrade with 2A modified stone and thoroughly compacted.

In blasting rock or other dense materials, the drilling and blasting must be conducted with all possible care. Rock to be blasted in trenches or for other structure excavations shall be backfilled with earth and then shall be covered with heavy timbers or other approved protective devices and shall be protected at their ends and secured, if necessary, prior to the actual blasting operation. All open work such as water mains - shall be suitably protected by a cover of timber and/or earth before each blast. In general, no blasts are to be set within fifteen feet of a completed water main. Blasting caps or other detonators shall in no case be kept near the place where explosives are stored; and in general, all precautions against accidents from blasting shall be entirely satisfactory, in accordance with these Specifications. No blasting shall be done on Sundays, holidays or on week days out of ordinary working hours except upon special approval by the Owner for each such specified request.

The Contractor shall assume all liability and responsibility connected with or occurring from blasting, or the use of explosives or dangerous material of any kind whatsoever. Such liability shall include, but is not limited to, damage to work or adjacent property, injuries, lawsuits, complaints, and all other adverse results, actual, alleged, inferred, or implied.

Excavation Methods- The use of trench-digging machinery will be permitted except where its operation will cause damage to trees, buildings, or existing structures (either surface or subsurface). At such locations, hand methods shall be employed to avoid such damage. All excavation work shall be completed in accordance with applicable OSHA guidelines, which includes, but is not limited to sheeting, bracing and overall trench excavation safety. If sheeting is employed, sheeting may be withdrawing as backfilling operations proceed in increments of (not more than) one (1) foot. The resulting void left by the withdrawn sheeting shall be backfilled and compacted.

Location of Excavated Materials- During trench excavation, the Contractor shall locate the excavated material so it will not completely obstruct the traveled roadways or streets. Unless otherwise approved, all streets and roadways shall be kept open to at least one-way traffic.

Removal of Water - The Contractor shall provide and maintain ample means and devices with which to promptly remove and dispose of all water entering the trench excavation during the time the trench is being prepared for the pipe laying, during the laying of the pipe and until the backfill at the pipe zone has been completed. The Contractor shall dispose of the water in a suitable manner without damage to adjacent property. If the water contains chlorine, means must be implemented to remove the chlorine from the water prior to allowing it to run off from the work area.

Preparation of Trench Bottom- Pipe shall not be laid directly on a trench bottom. Before the pipe is lowered into the trench, the trench bottom shall be prepared as follows: six inches (6") of 2A modified stone shall be made flat and cut true to grade so as to provide continuous contact of the trench bottom with the whole length of the pipe.

Initial Backfill- The first step in providing firm, continuous support for the pipeline is to tamp backfill material - 2A modified stone - solidly under the pipe and couplings. After the pipe lengths have been jointed, the bell holes and sides of the pipe shall be carefully backfilled with approved backfill material (2A modified stone) and thoroughly compacted utilizing an approved method of tamping. Pea gravel is not an approved bedding material.

Tamping in the initial backfill zone can be accomplished with tamping bars. Mechanical compactors shall not be utilized in the initial backfill zone directly on top of the pipe until a minimum of twelve (12) inches of backfill- 2A modified stone - has been placed over the pipe.

The 2A modified stone material utilized for the initial backfill shall be free of large stones, dry lumps, and in cold weather, free of frozen lumps. No pieces of material larger than one (1) inch shall be utilized in the initial backfill.

The initial backfill material shall be hand-placed evenly along both sides of the pipe in a layer not to exceed four (4) inches in thickness. This four (4) inch layer of backfill material shall then be tamped firmly under the haunches of the pipe so that there will be no voids under the pipe. Then the initial backfill shall be continued in layers not to exceed six (6) inches in thickness and thoroughly compacted until the 2A modified stone backfill is twelve (12) inches above the top of the pipe.

Trench Backfill - Trenches located in paved areas or areas proposed to be paved must be entirely backfilled with 2A modified stone. Trenches not in paved areas or proposed paved areas may be backfilled with the material excavated provided rocks of over one (1) inch maximum dimension and other deleterious material is removed. Material containing frost shall not be used for backfill. The first one (1) foot of backfill above the initial backfill shall be given careful attention as to composition. The entire backfill is to be firmly compacted, as hereinafter stipulated or by other methods, if approved. If the trench is located in an existing paved area, the trench must be restored with Hot Patch Material if available or Cold Patch Material at the end of each working day and maintained until the final trench restoration is performed.

Mechanical Tamping - Mechanical tamping with a mechanical tamper or approved equal can be utilized. The initial backfill zone shall be compacted in accordance with these specifications. The balance of the trench backfill shall be compacted by placing the backfill material in layers not to exceed eight (8) to twelve (12) inches in thickness and compacting said layers with mechanical tampers at least 95-percent of the density of the undisturbed surrounding materials. This method of backfill and compaction shall be utilized to bring the trench backfill to the original ground surface or where the trench is located in a travel way, to a depth below the original surface of the travel way as needed to accommodate the type of surface repair required, or where the trench is located in an area that requires grass seeding or sodding, to a depth below the original grass area as needed to accommodate the grass sod or the topsoil necessary for grass seeding. At the discretion of the Owner, field tests for density will be performed in accordance with ASTM Standard D1556-00 (Standard Test Method for Density and Unit Weight Soil in Place by the Sand-Cone Method) at no cost to the Contractor. Any area found to be of less the 95% compaction will require excavation and replacement of the backfill until 95% compaction is met on entirety of the trench length. Any excess material remaining alongside the trench after backfill and compaction has been completed is to be removed and disposed by the Contractor.

Surface Runoff Water - The Contractor shall at all times protect any open trench from the entrance of surface runoff water. In the event that water does enter a trench, the Owner may require the Contractor to furnish, at no additional cost to the Owner, the required foundation stabilization gravel to provide a suitable foundation for laying the pipe. The Contractor shall provide, at no additional cost to the Owner, temporary pipe plugs to prevent any surface or ground water from entering the water main.

#### D. Measurement and Payment

Excavation and Backfill- The work and material required under this item are to be included in the price per linear foot for the various sizes and types of water pipe in place. This shall include any costs associated with trench excavation and pipe bedding material.

**Rock Excavation**- The cost associated with rock excavation shall be included in the Contractor's base bid. Change orders will not be paid for rock excavation or excavation of existing obstructions within the proposed trench alignment.

On Developer Projects, extra cost for rock removal is the responsibility of the Developer and the cost should be evenly distributed across all line items.

Extra Depth Excavation- On Company Projects, extra depth excavation will be paid for at the unit price bid per cubic yard as set forth in the Add/Alternate Bid item for extra depth excavation and shall be considered full compensation for all labor, material, equipment, and related work thereto. The Contractor shall notify the Owner if extra depth excavation is encountered that will require additional cost. The Contractor shall schedule a meeting with the Owners Representative to discuss the extra depth excavation. The Contractor and the Owner shall jointly determine the amount of extra depth excavation, if it is substantial, and the additional cost for the work. The Contractor shall issue a Change Work Authorization (CWA) to the Owner for the additional cost based on the outcome of the meeting. The Owner's Representative shall review and approve the CWA before the Contractor starts any extra depth excavation.

On Developer Projects, cost for extra depth excavation is the responsibility of the Developer and the cost should be evenly distributed across all line items.

Pipe Bedding Material - Pipe bedding material will be included in the lump sum price bid for water main installation as set forth in the Bidder's Proposal Bid Sheet and shall be considered as full compensation for all labor, material, equipment, and related work thereto.

Contractor will not be compensated for pipe bedding material required to bring the trench bottom up to grade or fill trench sides in areas of over-excavation.

### **3. INSTALLATION OF WATERMAINS**

#### **A. Scope**

This section includes the work necessary for the installation of the water mains, valves, and fittings, including but not limited to excavation and backfill; furnishing all materials, which are not to be provided by the owner; fine grading the trench bottoms, providing base for the pipe where required; laying and jointing the pipe; installing the necessary valves and fittings; connecting new water mains to existing pipelines; pouring thrust blocks; hydrostatic testing of the new water mains; disinfection of the new water mains; final cleanup, and all incidental and related work.

#### **B. Materials**

##### **Company Projects**

The Owner will furnish all pipe, valves, fittings, and other pipeline appurtenances, and such other pipeline materials as may be required. The fact that the Owner is to furnish the pipeline materials is conclusive evidence of its acceptability for the purpose intended and the Contractor may continue to use it until otherwise directed. At no time will plastic fittings of any type be utilized.

The Contractor shall provide and pay for any materials as may be required in addition to the materials to be furnished by the Owner, which are necessary for the execution and completion of The Work. Materials to be provided by the Contractor shall include but are not limited to casing pipe, stainless steel spacers, neoprene end caps with stainless steel restraint clamps, bedding material, concrete, location wire, location tape, rodding material, grass seed or sod, bituminous paving materials, crushed stone and flowable fill.

##### **Developer Projects**

The Developer or Developer's Contractor will furnish all pipe, valves, fittings, and other pipeline appurtenances as may be required. The Developer's Contractor shall do all work and furnish all the labor, material, and equipment necessary or required to install water main projects and related service installations.

#### **C. Workmanship**

**Excavation, Backfill, and Bedding** - All excavation, backfill and bedding shall conform to these technical specifications.

Handling of Pipe and Accessories - All materials as provided by the Owner shall be furnished to the Contractor at the Owner's pipe storage yard or shop facility and shall be transported to the job site by the Contractor at his expense, except where, for the convenience of the Contractor and upon his written request or at the Owner's decision, delivery of pipe or other material to the job site can be accomplished by the material manufacturer. When the Contractor picks up material at the Owner's pipe storage yard or shop facility or the materials are delivered directly to the job site, the Owner's personnel should charge out materials to the contractor. The Contractor shall not pick up any material unless properly charged out to him and he shall be responsible for any material loss or damaged after receipt of the material. Upon acceptance of PVC pipe or polyethylene encased ductile-iron pipe delivered to a job site, the Contractor will provide sunlight exposure protection by covering the pipe with an opaque material such as canvas.

The pipe and accessories shall at all times be handled with care to avoid damage. The Contractor's methods of loading, transporting, and unloading pipe shall conform to the recommendations of the pipe manufacturer who is the supplier for the pipe to be utilized on the Owner's main extension projects. Whether moved by hand, skid loaders or hoists, material shall not be dropped or bumped. The interior and machined ends of the pipe shall be kept free from dirt and foreign matter at all times. In the distribution of material at the site of the work each piece shall be unloaded opposite or near the place where it is to be laid in the trench. Material shall not be distributed on the job any faster than it can be used in good advantage. In general, no more than one week's supply of material shall be distributed in advance of installation.

Pipe shall be handled in such a manner as to avoid damage to the machined ends. Pipe damaged at such points that cannot be repaired to the Owner's satisfaction shall be replaced at the Contractor's expense. When storing is necessary, the pipe should be stored off the ground in a flat area with the ends resting on plain timbers. Valves and hydrants shall be kept drained and stored before installation in a manner protecting them from damage due to freezing or trapped water. Pipe ends must be capped until attachment is made.

Detection Wire - Detection wire shall be installed by the Contractor in conjunction with the installation of all PVC and Ductile Iron mains. Detection wire shall be situated beneath the pipeline prior to installation of the pipe and looped up thru valve roadway boxes for the connection of Owner's locating/detection equipment. The Contractor shall include the cost of the installation of detection wire in the cost of the water main installation.

**Placing of Pipe and Accessories in Trench** - Implements, tools, and facilities satisfactory to the Owner shall be provided and used by the Contractor for the safe and efficient execution of the work. All pipes, fittings, valves, hydrants, and accessories shall be carefully lowered into the trench with suitable equipment in a manner that will prevent damage to pipe and fittings. Under no circumstances shall pipe or accessories be dropped or dumped into the trench. Pipe and accessories shall be inspected for defects prior to their being lowered into the trench. All foreign matter or dirt shall be removed from the interior and machined ends of pipe and accessories before the pipe and/or the accessories are lowered into position in the trench. Pipe shall be kept clean by means approved by the Owner during and after installation.

**Pipe Joining** - All PVC and DI pipe shall be laid with the bell end facing in the direction of work progress. On slopes exceeding ten (10%) percent, installation shall begin at the bottom of the slope and proceed upward. Joint restraints and/or field lock gaskets must be used on all slopes greater than 10%, first two full lengths of pipe from a bend, tee, coupling, etc., or as directed by the Owners representative.

### **Polyvinyl Chloride (PVC) Pipe**

Circular saws, handsaws, or similar equipment may be used for cutting PVC pipe. When pipe is cut in the field, the cut shall provide a smooth end at a right angle to the longitudinal axis of the pipe. Pipe spigot ends shall be de-burred, beveled, and re-marked with insertion line (a circumferential line on the spigot end of PVC pipes that references how far the spigot should be inserted into the adjoining PVC pipe bell). The spigot end of two sections of pipe to be jointed plus the bell end and rubber ring into which the spigot end is to be inserted shall be cleaned immediately before assembly. Joints shall be assembled in accordance with the recommendations of the pipe manufacturer who is the supplier for the PVC pipe to be utilized in the Owner's main extension projects. The mechanical joint shall be assembled in accordance with the fitting manufacturer's published recommendations. PVC joint deflection is not permitted, bends must be used. Pipe spigot bevels may require shortening for use with mechanical joints or fitting joints.

### **Polyethylene Tubing (PET)**

Circular saws, handsaws, tubing cutter, or similar equipment may be used for cutting PET. When PET is cut in the field, the cut shall provide a smooth end at a right angle to the longitudinal axis of the tubing. Tubing connections shall be assembled in accordance with the recommendations of the manufacturer who is the supplier for the PET to be utilized in the Owner's projects. Compression type fittings with inserts shall be used to assemble tubing in accordance with the fitting manufacturer's published recommendations.

### **Ductile-Iron (DI) Pipe**

Ductile-iron pipe may be cut using an abrasive pipe saw, rotary wheel cutter, guillotine pipe saw, milling wheel saw, or oxyacetylene torch if recommended by the pipe manufacturer. Cut ends and rough edges shall be ground smooth. Pipes selected for cutting should be field-gauged. A mechanical-joint gland inserted over the barrel might serve as a convenient indicator for this purpose.

When glands are not available, pipe can be selected by measuring with a tape in accordance with the manufacturer's recommendation.

When pipe installation is not in progress, a temporary line plug is to be placed in the open end of installed pipe to prevent entrance of trench water into the line. Whenever water is excluded from the interior of the pipe, enough backfill shall be placed on the pipe to prevent floating. Any pipe that has floated shall be removed from the trench and relayed as directed by the Owner. No pipe shall be laid in wet trench conditions that preclude proper bedding, or on a frozen trench bottom, or when, in the opinion of the Owner, the trench conditions or the weather conditions are unsuitable for proper installation.

### **Asbestos-Cement (AC) Pipe**

*Refer to Asbestos-Cement Pipe Repair, Removal and Disposal Standard Operating Procedure in Appendix A.*

**Assembly of Valves and Fittings** - Assembly of all Valves, Fittings or any other connection utilizing a mechanical joint must be connected with a mechanical restraint gland. Thrust blocking and/or rodding is required in addition to the mechanical restraint gland.

Valves and fittings shall be installed at the locations shown on the Plans or as directed by the Owner or both. All valves and fittings shall be supported in such a manner that their weight is independent of the adjacent pipe. Substantial supports shall be utilized under all valves and fittings. When concrete thrust blocks are utilized, the concrete shall be poured under and against the body of the valve or fitting to provide support.

Every valve or fitting connected to asbestos-cement pipe shall be connected using a ductile iron spool piece and an extended range transition coupling with stainless steel nuts, bolts, and washers. A mechanical joint solid sleeve and mechanical retainer glands shall be used to connect PVC and ductile iron pipe. Ductile iron and C900 PVC pipe shall be connected to asbestos-cement pipe and cast iron pipe using an extended range transition coupling.

Before valves or fittings are installed, all lumps, blisters, and excess coating shall be removed from the bell. The inside of the bell shall be wire-brushed and the inside of the bell and the spigot end of the pipe wiped clean and dry. All surfaces to be joined shall be kept clean until connection is made.

### **Thrust Blocking** (See Appendix B Typical Drawings)

a. **Limiting Pipe Diameter and Degree of Bend**- All pipelines four (4") inches in diameter or larger, all tees, plugs, caps, and bends exceeding 11-1/4°, and all other locations where unbalanced forces exist, shall be securely anchored by suitable thrust blocking as shown on the plans or hereinafter specified.

b. **Thrust Blocks**- Reaction or thrust blocks shall be placed as shown in the Thrust Blocking Schedule in the typical drawing section attached hereto and shall consist of concrete having a minimum twenty-eight (28) day compressive strength of not less than 3,000 pounds per square inch. Blocking shall be placed between the undisturbed ground and the fitting to be anchored. The quantity of concrete and the



area of bearing on the pipe shall be as shown in the Thrust Blocking Schedule in the typical drawing section attached to this document or as directed by the Owner. The blocking shall be placed so the pipe and fitting joints will be accessible to repairs.

c. Mechanical Restraints - Mechanical restraints (e.g. stainless steel threaded rods with Mega-Lugs, Field-Lok Gaskets) may be used in conjunction with concrete blocking as directed by the Owner. These restraints DO NOT replace the need for thrust blocks.

Setting of Bends, Tees, and Reducers - Bends, tees, and reducers shall be lowered into the trench, inspected, cleaned, and jointed as specified herein in this section of the Specifications for cleaning, laying, and jointing pipe and accessories. Thrust blocking shall be applied at bends and tees and at points at reducers or in fittings where changes in pipe diameter occur. The design of concrete thrust blocking shall be as specified in the Thrust Blocking Schedule in the typical drawing section attached to this document or as directed by the Owner.

Setting of Valves and Valve Boxes- Gate valves shall be resilient seat, mechanical joint type and must meet the requirements of the VEOLIA Product Requirement List. They shall be located as shown on the Plans or as directed by the Owner during construction. Valves shall be set and jointed to the pipe in the manner specified herein in this section of the Specifications for cleaning, laying, and jointing of pipe and accessories. A valve box shall be provided for every valve that is to be buried in the ground. The valve box shall not transmit shock or stress to the valve and shall be centered and plumb over the operating nut of the valve using a Valve Box Adaptor with the box installed flush with the surrounding surface, or at such other level as may be directed by the Owner.

Valve Extension Stems. Valve nut extensions shall be provided where the depth to the top of the valve operating nut exceeds five feet. The extension stem shall be a continuous length of solid hot rolled round stock 1-1/4 inch diameter round bar fitted with a 2 inch square operating nut on the top and a moveable self-centering device. The extension stem will have a square socket welded to the bottom. The socket is to be fabricated so as to fit on a standard 2 inch square valve operating nut.

Permanent Blow off – Blowoff shall be located at the end of dead-end mains as shown on the Plans or as directed by the Owner during construction. The blow-off shall conform to the details as shown on the VEOLIA drawings. The blow-off shall not be connected to any sewer, submerged in any stream, or installed in any other manner that will permit back-siphoning into the distribution system.

Temporary Blowoff – A temporary blowoff may be needed during the installation of the water main. The temporary blowoff(s) will be provided by the Contractor at his expense and will be returned to the Contractor at the completion of installation. Placement of a temporary blowoff will be determined by the Owner.

Installing Tapping Sleeve and Valve - A tapping sleeve and valve shall be utilized whenever an existing main has to be tapped under pressure in order to make a main extension. The location of tapping sleeves shall be as shown on the Plans or as directed by the Owner. The Owner shall supervise all taps over two (2) inches diameter. The Contractor may not commence the tapping of an existing main unless the Owner's Representative is present. If the Owner's Representative is not present

for the wet-tap procedure as a result of the Contractor not providing the Owner with sufficient notice, an extension will be applied to the duration of the Developer supplied Maintenance Bond, and the Contractor will be disciplined as provided in the Approved Contractor Annual Agreement.

All tapping sleeves shall be the wrap around FAST “Ford Type” with a stainless steel sleeve and ductile iron mechanical joint unless otherwise directed by the Owner.

Tapping sleeves shall be assembled and drilling accomplished in accordance with the manufacturer’s recommendations. Prior to assembly, the pipe barrel shall be cleaned thoroughly with a wire brush to provide a smooth, hard surface for the sleeve. The tapping sleeves shall be well supported independently of the pipe both during and after the tapping operation. Thrust blocking shall be utilized as specified in these specifications.

Tie-In to Existing Mains - A tie-in to an existing main is defined as a tie-in, which requires cutting out a section of the existing main and installing a tee or cross and all other fittings as required making a complete installation from which the Contractor can commence a new main extension. The location of tie-ins shall be as shown on the Plans or as directed by the Owner. All tie-ins shall be done under the Owner’s supervision.

The installation of a tee or cross and all other fittings as required to make a tie-in to an existing main shall conform to the requirements of these specifications.

Plugging of Dead Ends - Standard plugs or caps shall be installed at the end of dead-end mains where a blowoff assembly is not required. These plugged or capped mains shall be provided with restraint glands and reaction blocking in accordance with these specifications.

Abandoning Existing Mains - Whenever the Contractor is directed to abandon an existing main, he shall expose the pipeline at a location as shown on the Plans or as designated by the Owner, cut a short section out of the pipeline, install a plug or cap on the end of the pipe which is still connected to the distribution system, install concrete reaction blocking, restrain the plug or cap, and backfill the excavation all in accordance with the applicable portions of these Specifications.

Live Mains of Existing Facilities - All work done by the Contractor on existing mains, including tie-ins, shall be done under the Owner’s supervision. **In no case shall the Contractor open or close valves on the Owner’s existing system.** When it is necessary to disrupt the present water service in order to make required distribution main connections or tie-ins, the Contractor shall be allowed a maximum time limit for such disruptions of four (4) hours in any twenty-four (24) hour period unless otherwise approved by the Owner.

The Owner’s employees or representative shall perform all valve shutdowns. All affected customers must be given forty-eight (48) hours advance notice of a shut down. The Owner/Owner’s representative are responsible for the notification of customers. Upon direction by VEOLIA, select situations will require the contractor to notify affected customers with door-hanging notifications.

Installation of Pipe Under Other Utility Pipe – Water main installed under other pipe shall be as shown in the detail provided in Appendix B, Typical Drawings. Any water main crossing under a sanitary sewer pipe must be ductile iron, have the pipe connection joints installed 10 feet from the center line of the sanitary sewer pipe, be installed a minimum of 18 inches below the sanitary sewer pipe, and be installed at a 90° angle to the sanitary sewer pipe.

Any water main crossing under a storm sewer pipe 24 inch diameter or larger must be installed in a casing pipe 18 inches below the storm sewer pipe. Any water main crossing under a storm sewer pipe smaller than 24" diameter must be ductile iron, be installed a minimum of 18" below the storm sewer pipe, and have the pipe joints installed 10 feet from the center line of the storm sewer pipe.

Any water main crossing under gas transmission or distribution main six (6) inch diameter and larger shall be installed in casing pipe a minimum of 18 inches below the gas main.

Installation of Pipe in a Casing - In certain installations such as some highway crossings, pipe crossing, and railroad crossings, it will be required that the water main be installed inside a casing pipe. The size and length of casing pipe to be utilized and its location shall be as shown on the Plans or as directed by the Owner. The casing material shall be supplied by the Contractor. The pipe material inside a casing pipe must be ductile iron. The casing pipe shall be as sized by VEOLIA. Metal-to-metal contact must be avoided.

There are two methods by which the casing pipe can be installed. One is the standard open trench method and the other method requires tunneling, boring or jacking of the casing pipe. The Owner shall designate the type of casing installation method to be utilized prior to construction.

Pipe installed in a casing shall utilize stainless steel casing spacers - three spacers per joint of pipe, and neoprene rubber casing end seals with stainless steel straps. Field Lock gaskets are required at all bell and spigot connections inside of the casing. Stainless steel casing spacers, neoprene rubber casing end seals, and Field Lock gaskets are to be supplied by the Contract and included in the lump sum amount of the water main installation.

If the Owner's Representative is not present for the bore procedure as a result of the Contractor not providing the Owner with sufficient notice, the duration of the Maintenance Bond will be extended to five-years.

### Installation of Pipe Via Horizontal Directional Drill

This section consists of all pressure pipe installation that will be permitted to be installed by horizontal directional drilling methods (HDD).

The Contractor will furnish the C900 DR-18 fusible PVC water main and DIP/PVC couplings. The Contractor shall provide and pay for any materials as may be required in addition to the materials to be furnished by the Owner, which are necessary for the execution and completion of the work involved in the installation of the HDD.

The Contractor shall retain the services of a horizontal directional drilling specialist who can provide at least three (3) references of previous similar projects completed requiring similar skills.

Submit a complete detailed design procedure and method for each installation showing the following as a minimum:

1. Layout sketches, indicating pit dimensions and locations.
2. Proposed line and grade of the drilling.
3. Complete details and specifications of the materials and equipment to be used to complete the drilling installation.
4. Size and type of drill pipe.
5. Drilling fluid information.
6. Drilling fluid disposal plan.
7. Sequence of operations.
8. A list of personnel and their qualifications and experience (including back-up personnel in the event that an individual is unavailable).
9. A safety plan.

Contractor shall follow the approved installation plan(s) for the given project. Contractor shall communicate installation concerns with VEOLIA representative immediately. Alteration of the HDD plan(s) must be approved by applicable permitting agencies b

If an obstruction is encountered that prohibits the forward action of the drilling operation or pipe installation, and it becomes evident that it will be impossible to advance the drill head or the pipe, operations shall cease and the pipe will be abandoned in place and filled completely with grout. Drilling shall restart at a second location. Any such additional cost associated with such a restart at a new location shall be borne by the contractor.

The HDD operation, once started, shall be continuous until the HDD is completed.

The rig shall be capable of the push/pull capacity, rotational speed, torque, and horsepower requirements, including size and capacity of the drilling fluid pump, to successfully complete the HDD.

During construction, the surfaces of all areas including, but not limited to roads,

streets, and driveways shall be maintained on a daily basis to produce a safe, desirable, and convenient condition. Streets shall be swept and flushed after backfilling, and re-cleaned as dust, mud, stones and debris caused by the work, or related to the work again accumulates. The construction site shall be left clean at the end of each working day to the satisfaction of Engineer.

The Contractor shall keep drilling logs. These logs shall include specific dates, time and locations (x, y, z positioning), soil conditions, drilling data such as depth, angle, rate of penetration, and utility crossings. Drilling logs shall be accurate to facilitate the production of as-constructed / record drawings. The "x,y,z" locations shall be no further than 30' apart. Four (4) copies of the drilling logs shall be provided by Engineer.

The HDD Contractor shall monitor and record the alignment and depth readings provided by the tracking system:

1. Every 25 to 30 feet for normal conditions.
2. Every 5 to 10 feet where precise alignment control is necessary.

All drilling operations shall include reaming of the pilot hole prior to installation of the product line. The pilot hole shall be reamed to a minimum size of 1.5 times outside diameter of the product line. Reamer shall be chosen to match the soil conditions encountered. A wireline steering tool system shall be used for all drilling over 500', or drilling beneath a water allow drilling operations may be guided via a walkover system subject Engineer approval.

The driller shall use two-way radio or cellular phone communication between the drill rig operator and the pipe pull-back crew to assure that the pipe begins moving immediately upon the operator's commencement of the pull-back operation. The drill pipe shall be connected to the product line using a pull head or pulling eye and swivel. A reamer shall be placed between the drill pipe and pull head to insure that the hole stays open during the pull-back.

The Contractor shall employ the services of a certified fuser. The entire length of the pipe, for the drilling operation, shall be fused prior to installation. Contractor shall provide all necessary rollers to accommodate movement of the pipe above ground during the pull-back operation. Contractor shall provide necessary means (i.e. scaffold mounted rollers with a minimum vertical clearance) to maintain access roads and driveways during pull-back operations. All restoration for pits, service access, etc. shall be in accordance with the requirements of the project manual.

### Hydrostatic Testing

a. General - All pipelines complete with valves, fittings, and other facilities shall be hydrostatically tested in accordance with ANSI/AWWA C605-95 (AWWA Standard for Underground Installation of Polyvinyl Chloride (PVC) Pressure Pipe and Fittings for Water) and ANSI/AWWA C600-99 (AWWA Standard for Installation of Ductile-Iron Water Mains and Their Appurtenances). The pipelines shall be tested after they have been installed and filled with water for a minimum period of twenty-four (24) hours. The test pressure shall be at 150 psi or as specified by the Owner. If

the Contractor elects to tap service and/or make tie-ins before the test (this is only permissible on Developer Projects), then the same leakage maximum shall govern as if the taps and/or tie-ins were not made. All hydrostatic tests shall be conducted in the presence of the Owner or Owner's representative for approval.

A test shall be made only after a part or all backfilling has been completed and at least seven (7) days after the last concrete thrust block has been cast, unless high early concrete is used in which a minimum of 24 hours is then acceptable. The duration of the hydrostatic test shall be two (2) hours unless otherwise directed by the Owner.

b. Testing Procedure - The following procedure is based on the assumption that the pressure and leakage tests will be performed at the same time.

Each section of pipeline shall be slowly filled with water and the specified test pressure shall be applied by means of a pump connected to the pipe in a manner satisfactory to the Owner. The Contractor shall provide the complete means of conducting the hydrostatic test, including pumps and all related equipment. The Owner's Representative must witness the two (2) hour pressure test if the use of the Owners chart pressure recorder is not available. The Chart Recorder will be supplied to the Contractor and its installation shall be witnessed. At the conclusion of the 2 hour time period, the Owner or its Representative must witness the termination of the test and the recorders removal. If the Contractor removes the recorder without the Owner being present, the test is voided and must be repeated. Contractor is liable for any damage to the chart recorder while in his possession.

During the filling of the pipe and before the application of the specified test pressure, all air shall be expelled from the pipeline, if necessary, by means of taps at points of highest elevation. After completion of the test, the taps shall be tightly plugged, unless otherwise specified. Any joint at which the accumulated leakage exceeds the rate as specified in the following tables shall be rejected. All cracked or defective elements shall be removed and replaced by the Contractor at his expense. The test shall then be repeated until the results are satisfactory to the Owner. At the conclusion of the test, the Owner shall witness the line pressure reduced to zero psi.

c. Overall Leakage - No pipe installation will be accepted until the leakage for the section of pipeline being tested in less than the rate of leakage specified in the above tables.

When testing against closed metal-seated valves, an additional testing allowance per closed valve of 0.078 gph/in of nominal valve size shall be allowed. When hydrants are in test section, the test shall be made against closed hydrant valves. All visible leaks shall be repaired, regardless of the amount of leakage. If the leakage in any section of pipeline tested is greater than that permitted, the Contractor shall locate and repair the defective joints at his own expense until the leakage is within the permitted allowance.

Disinfection- Before the pipeline is placed in service and before certification of completion by the Owner, all new mains installed by the Contractor shall be

disinfected in accordance with ANSI/AWWA C651-99 (AWWA Standard for Disinfecting Water Mains) or to the satisfaction of the Owner. Following chlorination, ductile-iron mains shall be flushed as soon as possible (within twenty-four (24) hours) because prolonged exposure to high concentrations of chlorine might damage the asphaltic seal coating. The Contractor shall furnish all chemicals and equipment required for the disinfection of mains. The Contractor shall be responsible to inject or place the chemical in the pipeline as directed. Disposal or neutralization of disinfection water shall comply with applicable regulations.

**Allowable Leakage per 50 joints of PVC pipe\* -- gallons per hour (gph)**

Nominal Pipe Diameter, <i>in.</i>												
Avg. Test Pressure, Psi	4	6	8	10	12	14	16	18	20	24	30	36
300	0.47	0.70	0.94	1.17	1.40	1.64	1.87	2.11	2.34	2.81	3.51	4.21
275	0.45	0.67	0.90	1.12	1.34	1.57	1.79	2.02	2.24	2.69	3.36	4.03
250	0.43	0.64	0.85	1.07	1.28	1.50	1.71	1.92	2.14	2.56	3.21	3.85
225	0.41	0.61	0.81	1.01	1.22	1.42	1.62	1.82	2.03	2.43	3.04	3.65
200	0.38	0.57	0.76	0.96	1.15	1.34	1.53	1.72	1.91	2.29	2.87	3.44
175	0.36	0.54	0.72	0.89	1.07	1.25	1.43	1.61	1.79	2.15	2.68	3.22
150	0.33	0.50	0.66	0.83	0.99	1.16	1.32	1.49	1.66	1.99	2.48	2.98
125	0.30	0.45	0.60	0.76	0.91	1.06	1.21	1.36	1.51	1.81	2.27	2.72
100	0.27	0.41	0.54	0.68	0.81	0.95	1.08	1.22	1.35	1.62	2.03	2.43
75	0.23	0.35	0.47	0.59	0.70	0.82	0.94	1.05	1.17	1.40	1.76	2.11
50	0.19	0.29	0.38	0.48	0.57	0.67	0.76	0.86	0.96	1.15	1.43	1.72

*\*If the pipeline under test contains sections of various diameters, the testing allowance will be the sum of the testing allowance for each size.*

**Ductile-Iron hydrostatic testing allowance per 1,000 feet of pipeline\* -- gallons per hour (gph)**

Avg. Test Pressure	Nominal Pipe Diameter - <i>in.</i>														
Psi	3	4	6	8	10	12	14	16	18	20	24	30	36	42	48
450	0.48	0.64	0.95	1.27	1.59	1.91	2.23	2.55	2.87	3.18	3.82	4.78	5.73	6.69	7.64
400	0.45	0.60	0.90	1.20	1.50	1.80	2.10	2.40	2.70	3.00	3.60	4.50	5.41	6.31	7.21
350	0.42	0.56	0.84	1.12	1.40	1.69	1.97	2.25	2.53	2.81	3.37	4.21	5.06	5.90	6.74
300	0.39	0.52	0.78	1.04	1.30	1.56	1.82	2.08	2.34	2.60	3.12	3.90	4.68	5.46	6.24
275	0.37	0.50	0.75	1.00	1.24	1.49	1.74	1.99	2.24	2.49	2.99	3.73	4.48	5.23	5.98
250	0.36	0.47	0.71	0.95	1.19	1.42	1.66	1.90	2.14	2.37	2.85	3.56	4.27	4.99	5.70
225	0.34	0.45	0.68	0.90	1.13	1.35	1.58	1.80	2.03	2.25	2.70	3.38	4.05	4.73	5.41
200	0.32	0.43	0.64	0.85	1.06	1.28	1.48	1.70	1.91	2.12	2.55	3.19	3.82	4.46	5.09
175	0.30	0.40	0.59	0.80	0.99	1.19	1.39	1.59	1.79	1.98	2.38	2.98	3.58	4.17	4.77
150	0.28	0.37	0.55	0.74	0.92	1.10	1.29	1.47	1.66	1.84	2.21	2.76	3.31	3.86	4.41
125	0.25	0.34	0.50	0.67	0.84	1.01	1.18	1.34	1.51	1.68	2.01	2.52	3.02	3.53	4.03
100	0.23	0.30	0.45	0.60	0.75	0.90	1.05	1.20	1.35	1.50	1.80	2.25	2.70	3.15	3.60

*\*If the pipeline under test contains sections of various diameters, the testing allowance will be the sum of the testing allowance for each size.*

**D. Measurement and Payment**

Installation of Water Main- Measurement and payment for installing water distribution pipe as furnished by the Owner shall be based on the lump sum price as set forth in the Bidder's Proposal Bid Sheet.

The lump sum price shall be considered as full payment for installing the pipe and should include the following: transporting all materials to the job site; installation of the pipe, valves, fittings, thrust blocks, detection wire and all other pipeline appurtenances as required for a complete installation; hydrostatic testing of the pipeline; disinfection of the pipeline; restoration and clean-up; furnishing and installing pipe bedding material; furnishing and installing select backfill material; installing blowoff assemblies; installing tapping sleeves and valves; making tie-ins to existing mains; installing casing pipe; abandoning existing mains; removal of existing asphalt or concrete; excavation of encountered materials (including rock) furnishing and installing asphalt surface repair; furnishing and installing concrete surface repair; traffic control; and furnishing and installing grass seeding and/or sodding.

If not listed as a separate Add/Alternate Bid Item in the Bidder's Proposal Bid Sheet, the lump sum price shall also include payment for trench extra depth excavation.

#### **4. INSTALLATION OF FIREHYDRANTS**

##### **A. Scope**

This section includes the work necessary for the installation of fire hydrants, including but not limited to providing all necessary tools and equipment as required to install fire hydrants; excavation and backfill; furnishing any required materials which are not to be provided by the Owner; transporting all materials to the job site; installation of the tee at the main; installation of six(6) inch diameter hydrant lateral; installation of the auxiliary valve and valve box; setting of the hydrant; provision of thrust blocking; provision of stone or concrete block for foundation and gravel for drainage; final clean up; and all incidental and related work.

##### **B. Materials**

###### **Company Projects**

The Owner will furnish the fire hydrants; auxiliary valves and valve boxes, fittings, pipe and all other materials as may be required. The fact that the Owner is to furnish the material is conclusive evidence of its acceptability for the purpose intended and the Contractor may continue to use it until otherwise directed.

The Contractor shall provide and pay for any materials as may be required in addition to the materials to be furnished by the Owner, which are necessary for the execution and completion of the work involved in the installation of fire hydrants. Materials to be provided by the Contractor shall include but not be limited to concrete for thrust blocking; stone or concrete block for foundation; gravel for drainage; asphalt, concrete, and gravel for surface repair; and grass seed or sod as may be required.

###### **Developer Projects**

The Developer or Developer's Contractor will provide and pay for all fire hydrants; auxiliary valves, valve boxes, fittings, pipe and all other materials as may be



required for the execution and completion of the work involved in the installation of fire hydrants. The Developer's Contractor shall do all work and furnish all the labor, material, and equipment necessary or required to install fire hydrants. Materials to be provided by the Contractor shall include but not be limited to concrete for thrust blocking; stone or concrete block for foundation; gravel for drainage; asphalt, concrete, and gravel for surface repair; and grass seed or sod as may be required. All fire hydrants must be fitted with a "Storz" connector on the steamer port

### C. Workmanship

Excavation and Backfill- All excavation and backfill shall conform to these Specifications.

Handling of Materials- All materials as provided by the Owner shall be furnished to the Contractor at the Owner's pipe storage yard or shop facility and shall be transported to the job site by the Contractor at his own expense. When the Contractor picks up material at the Owner's pipe storage yard or shop facility, the Owner's personnel shall charge out material to the Contractor. The Contractor shall not pick up any material unless properly charged out to him and he shall be responsible for any material loss or damage after receipt of the material.

The fire hydrant materials shall at all times be handled with care to avoid damage. Material shall not be distributed on the job any faster than it can be used to good advantage. In general, no more than two days' supply of fire hydrant materials shall be distributed in advance of installation. The fire hydrants and related materials shall be maintained free from dirt and foreign matter and shall be stored prior to installation in such a manner that they will be kept drained in order to prevent damage due to freezing of trapped water.

Location of Fire Hydrants- Fire hydrants shall be located as shown on the Plans or as directed by the Owner. The hydrants shall be located to provide complete accessibility and to minimize the possibility of damage from vehicles or injury to pedestrians.

When placed behind the curb, the hydrant barrel shall be set so that no portion of the pumper or hose nozzle cap will be less than six (6) inches or more than twelve

(12) inches from the gutter face of the curb. When set in the space between the curb and the sidewalk or between the sidewalk and the property line, no portion of the hydrant or nozzle cap shall be within six (6) inches of the sidewalk.

All hydrants shall stand plumb and shall have their nozzles parallel with or at right angles to the curb with the 5-1/2" nozzle facing the curb. Hydrants shall be set to the established grade, with the nozzles at least eighteen (18) inches above ground, as shown or as directed by the Owner. Traffic-model hydrants (hydrants that are intended to fail at the ground line on vehicle impact) shall be installed so that the breakaway flange is not less than two (2) inches, or more than six (6) inches, above the established grade.

**No exceptions will be made to this requirement.** The installed hydrant must be of the proper bury depth as to not require an extension at the time of the installation of the hydrant unless the hydrant lateral is at a depth that exceeds the manufacturer's maximum produced bury depth. If this case is encountered, the Owner must be

contacted in order to determine the method of installation of the hydrant.

Connection to Main- Unless otherwise specified, all fire hydrants shall be short sided main connections, with a six (6) inch ductile iron pipeline controlled by a dedicated six (6) inch gate valve. The maximum length of six (6) inch ductile iron pipe required between the tee at the main and the fire hydrant is no more than twelve (12) feet unless approved by VEOLIA. Installation will include a hydrant tee connected to a gate valve and a mechanical restraint gland between the valve and the ductile iron pipe.

Fire Hydrant Drainage- Fire hydrants shall be set with a drainage pit two (2) feet in diameter and two (2) feet deep below each hydrant. The pit shall be filled compactly with 2B stone under and around the bowl of the hydrant to a level six (6) inches above the waste opening.

Fire Hydrant Foundation- Fire hydrants shall be set upon a stable foundation consisting of a stone or solid concrete block. The solid concrete block shall be at least twelve (12) inches square by four (4) inches thick.

Anchorage of Fire Hydrants- The bowl of each fire hydrant shall be well braced against unexcavated earth at the end of the trench with concrete blocking. The concrete thrust blocking shall be placed so as not to obstruct the drainage outlet of the hydrant. The size and shape of concrete thrust blocking shall be as shown on the attached contract drawings at the end of these Specifications and the thrust blocking shall conform to the requirements of these Specifications. When hydrant is installed in unpaved areas, a 3,500psi concrete collar measuring twelve (12) inches all round and twelve (12) deep shall be installed six (6) inches below finished grade.

#### D. Measurement and Payment

Installation of Fire Hydrants- Measurement and payment for installing fire hydrants as furnished by the Owner shall be based upon the lump sum price for installing all fire hydrants as set forth in the Bidder's Proposal Bid Sheet.

The lump sum price shall be considered as full payment for installing the fire hydrants, and should include transporting all materials to the job site; excavation and backfill; installation of the tee at the main; installation of six (6) inch hydrant lateral; installation of hydrant barrel extensions; installation of the auxiliary valve and valve box; setting of the fire hydrant; provision of thrust blocking; provision of stone or concrete block for hydrant foundation; provision of gravel for drainage; restoration and cleanup; and all other items as required to provide a complete installation and which are not paid for under a separate bid item.

## **5. INSTALLATION OF SERVICES**

### **A. Scope**

This section includes the work necessary for the installation of services, including but not limited to, providing all necessary tools and equipment as required to make service installations; excavating and backfill; furnishing all materials which are not to be provided by the Owner; transporting all material to the job site; installation of the tap at the main, utilizing either a corporation stop or tapping saddles; installation of the curb stop and curb box; final cleanup; and all incidental and related work.

### **B. Materials**

#### **Company Projects**

The Owner will furnish all service materials including corporation stops, tapping saddles, service pipe, curb boxes, curb stops, etc. as required for service installation on Company projects. The fact that the Owner is to furnish material is conclusive evidence of its acceptability for the purpose intended and the Contractor may continue to use it until otherwise directed.

The Contractor shall provide and pay for any materials as may be required in addition to the materials to be furnished by the Owner that are necessary for the execution and completion of the work involved in the installation of services. Materials to be provided by the Contractor shall include, but not be limited to, pipe bedding material; select backfill material; asphalt, concrete and travel for surface repair; and grass seed or sod as may be required.

#### **Developer Projects**

The Developer or Developer's Contractor will provide and pay for all service materials including corporation stops, tapping saddles, service pipe, curb boxes, curb stops, meter pits, etc. as required for service installation. The Developer's Contractor shall do all work and furnish all the labor, material, and equipment necessary or required to install fire hydrants. Materials to be provided by the Contractor shall include, but not be limited to, pipe bedding material; select backfill material; asphalt, concrete and travel for surface repair; and grass seed or sod as may be required.

### C. Workmanship

1. General- The installation of services shall be done in a neat and workman like manner and shall conform to the applicable portions of these Specifications.

Before installing any service, the Contractor shall obtain applicable Record of Service (tap sheets) forms from the Owner. Record of Service Forms (tap sheets) shall be properly completed and returned to the Owner with appropriate invoices. Proper training will be given to the Contractor on how the Record of Service Forms (tap sheets) shall be completed upon request of the Contractor. It shall be the Contractor's responsibility to educate his field personnel on the procedures for properly completing the Record of Service Forms (tap sheets).

2. Excavation and Backfill- All service bedding material shall be comprised of silica sand (NON-LIMESTONE).

3. Handling of Materials - for Company Projects, all service materials as provided by the Owner shall be furnished to the contractor at the Owner's pipe storage yard or shop facility and shall be transported to the job site by the Contractor at his own expense. When the Contractor picks up material at the Owner's pipe storage yard or shop facility, the Owner's personnel shall charge out material to the Contractor. The Contractor shall not pick up any material unless properly charged out to him and he shall be responsible for any material loss or damage after receipt of the material.

The service materials shall at all times be handled with care to avoid damage. Materials shall not be distributed on the job any faster than they can be used to good advantage. The service materials shall be adequately stored on the job site prior to installation so as to maintain said materials free from dirt and other foreign matter.

4. Location of Services- Service lines and the related curb stops shall be located as shown on the VEOLIA drawings, or as staked in the field by the Owner's personnel. The depth of service lines shall be four (4) feet below established street grade or finished ground elevation unless otherwise directed by the Owner. Curb Stops shall not be located in concrete sidewalks or paved areas unless directed by the Owner. When, at the direction of the Owner, a Curb Stop is located in a paved area, an approved roadway rated Curb Box must be utilized. This box type must be approved by the Owner prior to its installation. If a contractor installs a standard Erie Style Curb Box in a paved area, the Curb Box will be removed and replaced with an approved roadway rated Curb Box at the Contractors expense prior to acceptance of the main and services. Curb stops are to be located at the Public Right of Way line or edge of easement.

## 5. Service Taps

### Polyvinyl Chloride (PVC) Pipe

Corporation stops shall be utilized for tapping PVC mains. All corporation stops to be installed shall have AWWA threads unless otherwise directed by the Owner.

Direct tapping of PVC is not permitted. Service saddles must be utilized. Tapping is prohibited in any discolored area. The core drill must have a throat depth sufficient to accommodate walls as thick as pressure class 200 pipe. Single-tooth, core drill cutters shall not be used. Multiple taps in a single pipe shall be at least eighteen (18) inches apart when measured along the longitudinal axis of the pipe.

The tapping machine used shall be in good condition. It is important that the boring bar does not wobble.

Use graphite and oil as a lubricant during drilling. Mix powdered graphite and linseed oil to the consistency of medium weight motor oil and brush it on the drill and also on the corporation stop before insertion.

Do NOT force the drill through the pipe wall. Use a light even pressure on the boring bar.

A test tap shall be made and the boring bar shall be marked for the proper tapping depth.

When the stop is inserted and tightened there should be one to three threads showing (no more). Always insert corporation stop with the machine used for tapping the pipe and care should be taken that the tapping machine does not move on the pipe.

A bend or gooseneck shall be provided in the service line adjacent to the corporation stop to allow for settlement or expansion or contraction or other pulling or thrusting. Care should be taken in backfilling and tamping so that heavy materials are not thrown or dumped on the service tap and that tamping over the service tap does not occur.

Saddle tapping involves making a service connection through the use of a service clamp or saddle. All sizes and classes of PVC pipe must be tapped using a service clamp or saddle. The maximum outlet size with a service clamp or saddle shall be two (2) inches. If a tap larger than two (2) inches is required, a tapping sleeve and valve shall be used. All service clamps or saddles shall provide a sufficient bearing area. A minimum of two (2) inches total width along the pipe's axis shall be required for taps up to one (1) inch in size to prevent pipe distortion when the saddle is tightened. Taps 1-1/4 inch through two (2) inches should have a minimum of three (3) inches total band width with full circumferential support. Narrow U- bolt-type straps and saddles having lugs that dig into the pipe wall, and brass service saddles are prohibited.

When making service taps larger than two (2) inches, a tapping sleeve and valve or a tee shall be utilized for the connection at the main. Installation of a tapping sleeve and valve or a tee shall conform to the applicable portions of these Specifications. Installation of the tapping sleeve and service line shall be paid under the appropriate water main installation item.

Ductile-Iron (DI) Pipe

Ductile-iron pipe 8" diameter and above may be directly tapped with standard corporation stops up to and including one (1) inch. Service saddles must be utilized for two (2) inch corporation stops on DI pipe 8" diameter and above. DI Pipe diameter below 8" must be tapped using a service clamp or saddle, regardless of service diameter.

Service taps on ductile-iron mains encased in polyethylene may be accomplished by making an X-shaped cut in the polyethylene and temporarily folding back the film. After the tap has been completed, cuts in the polyethylene and any other areas of damage to the film shall be repaired as described in ANSI/AWWA C105-A21.5 (American National Standard for Polyethylene Encasement for Ductile-Iron Pipe Systems). Direct service taps may also be made through the polyethylene, with any resulting damaged areas being repaired as previously described. The preferred method of making direct service taps consists of applying two or three wraps of polyethylene adhesive tape completely around the pipe to cover the area where the tapping machine and chain will be mounted. This method minimizes possible damage to the polyethylene during the direct tapping procedure. After the tapping machine is mounted, the corporation stop is installed directly through the tape and polyethylene. This method is very effective in eliminating damage to the polyethylene encasement by the tapping machine and chain during the tapping operation. After the direct tap is completed, the entire circumferential area should be closely inspected for damage and repaired if needed.

Service taps of dissimilar metals also shall be wrapped with polyethylene or a suitable dielectric tape for a minimum clear distance of three (3) feet away from the ductile-iron main.

6. Meter Pits – VEOLIA Specified meter pit is required for all service installations unless otherwise directed by VEOLIA. The meter pit must be installed within five (5) feet of the curb stop on the Customer's property. Curb stops shall be installed on the property/right-of-way line. Exceptions may be authorized by VEOLIA on a case by case basis.
7. Abandoning Existing Service Installations - Whenever the Contractor is directed to abandon an existing service installation, he shall expose said service at the point where it connects into the main, shut off the corporation stop and disconnect the service line at the corporation stop, remove the curb stop, and provide necessary surface repair and cleanup. The workmanship required for abandoning an existing service installation should be in accordance with the applicable portions of these Specifications.

8. Service Reconnection - Whenever an existing water main is replaced with a parallel new water main, and the existing services are not being replaced as part of the water main replacement, the Contractor shall be required to reconnect the existing service lines to the new main. This will require installing a tap on the new main and connecting the existing service line to the new water main. The tap for a service reconnect shall be installed on the new main in line with the existing service line to which it is to be connected.

The Contractor shall not make a service reconnection until the new main is completely installed, tested, and ready to be utilized. Before actually installing a service tie-over, the Contractor will also be required to give the affected customer at least twenty four (24) hours advance notification of the disruption to be expected in their water service. The water service to a customer shall not be disrupted for more than two (2) hours during the installation of a service tie-over unless otherwise approved by the Owner.

D. Measurement and Payment

Installation of 3/4" through 2" Service Lines - Measurement and payment for installing all service pipes as furnished by the Owner shall be based upon the lump sum price for installing all services as set forth in the Bidder's Proposal Bid Sheet.

The lump sum price for services shall be considered as full payment for installing the service lines and should include transporting all materials to the job site; installation of the tap at the main utilizing a corporation stop; installation of the specified size of service pipe between the tap at the main and the curb stop and box; installation of detection wire for plastic services; restoration and cleanup; and all other items as required to provide a complete service line installation, which are not paid for under a separate bid item.

## **9. SURFACE REMOVAL & RESTORATION**

### **A. Scope**

This section covers the work and materials necessary to remove and replace all pavement and all concrete curb and gutter, sidewalks, and driveways as required for construction of the facilities included under this Contract plus replace all gravel surfacing and lawn areas that are damaged directly or indirectly by any of the operations incidental to this Contract. This item shall include furnishing all labor, materials, and equipment required to give a complete job. All gravel surface repair plus all concrete replacement for curb and gutter, sidewalks, and driveways shall be done in accordance with the regulating county or state highway department specifications.

### **B. Materials**

All materials furnished for stone backfill, stone stabilization, stone base, bituminous paving, concrete paving and/or base, concrete curbs and concrete sidewalks shall conform to the applicable provisions of Pennsylvania Department of Transportation Form 408 (latest revised edition) or the standards of the applicable municipality.

### **C. Workmanship**

#### **1. Pavement Repair**

a. General - A SUPERPAVE mix with an ESAL count of 0.3 to < 3.0 million is the standard asphalt pavement restoration requirement for VEOLIA projects.

All workmanship for the various types of pavement and gravel repair as specified herein shall either meet the requirements of the agency that has regulatory control of the street or highway being repaired (i.e. the local municipality, Pennsylvania Department of Transportation, etc.) or VEOLIA general and/or project specific specifications, whichever is more stringent. Batch plant weigh slips/ truck tickets shall be forwarded to the VEOLIA inspector for material confirmation.

b. Pavement Cutting and Removal - All paving, whether concrete or bituminous surfaces, in the public right-of-way shall be cut in neat, straight lines. Contractor is responsible for controlling dust. Hydro-hammer cuts will not be permitted.

Broken asphalt and concrete pavement removed during excavation operations shall not be utilized in the trench as backfill material. The Contractor shall be required to haul said material off-site and dispose of it at his own expense.

c. Pavement Surface Repair - All backfill is to be compacted in accordance with the latest PennDOT Design Manual 2 to the full depth of the trench and then excavated to the proper depth for patching, unless patching is performed immediately behind compaction and on the same day of backfilling. There shall be a minimum of eight (8) inches of 2A modified stone below the lower surface of the pavement patch.

Prior to replacement of pavement over trenches, edges of the existing pavement shall be cut back one (1) foot and all edges shall be uniformly supported on firm base material, and shall be the same final elevation of the surrounding pavement.



Temporary Pavement – Unless otherwise directed, temporary pavement will be installed in all water main and water service trenches at the end of each work day.

Temporary pavement shall be as required by PennDOT or local Municipality and at a minimum consist of two (2) inches of cold patch material or hot mix, as approved by the Company's Representative, which shall be rolled or tamped to a level that is consistent with the surrounding pavement. Temporary paving shall be maintained by the Contractor until the final paving is placed.

d. Stone Surface Repair - Graveled roads, alleys, and shoulders shall be left with a minimum of two (2) inches of 2A modified stone leveled to the existing grade.

In gravel right-of-ways, existing gravel may be reused if the gravel is kept free of dirt and debris.

2. Concrete Curb and Gutter, Sidewalks, and Driveways - Concrete curb and gutter, sidewalks, and driveways shall be replaced to the same depth and to the same line and grade as that removed or damaged unless otherwise directed by the proper regulatory agency. The width of the replaced section of concrete shall extend one (1) foot on each side of the trench. The face of the concrete cut shall be sawed and shall be straight and plumb both horizontally and vertically. Prior to placing the sections of curb and gutter, sidewalks, and driveways, the trench shall be properly backfilled and compacted to prevent subsequent settlement. The permanent sidewalk restoration shall include material to match existing sidewalk material. Width and thickness of restored sidewalk shall match existing sidewalk or Company sidewalk specifications, whichever is greater. All match edges shall be saw cut. The permanent driveway restoration shall include material to match existing driveway. Width and thickness of driveway shall match thickness and width of existing driveway or Company driveway specifications, whichever is greater.

D. Lawn/Grass Areas - Lawn/grass areas will be replaced to the same grade as that removed or damaged unless otherwise directed by the Owner. Subgrade will be six (6) inches lower than finish grade to accommodate six (6) inches of Screened Topsoil. The lawn/grass restoration shall include a minimum of six (6) inches of high quality screened top soil, grass seed or sod to match existing grass, starter fertilizer, correctly installed straw matting or loose straw mulch for seeded areas, and written directions to Customer for maintenance of permanently restored area. Lawn/grass restoration shall be completed within one (1) week of completing the work.

E. Measurement and Payment

The work and material required under this item are to be included in the price of water main in place.

# VEOLIA WATER PENNSYLVANIA INC.

## PROJECT CLOSE OUT SECTION

### 1. INTRODUCTION

This section describes the steps and processes for the completion and acceptance by the Owner of a water main extension project and/or replacement project. These steps and processes are in place to assure that the project completed by the Contractor is in an acceptable condition to safely supply the Owner's customers with reliable service, to insure that the records of the installed water main extension or replacement have been properly produced in the acceptable format, and that all necessary paperwork has been provided to the Owner.

### 2. BACTERIAL SAMPLING

#### **Company Projects**

Upon the completion of a water main extension project including the passing of pressure test administered by the Owner, and before the installation of the services, the water main will be flushed in accordance with AWWA standards and sampled for the presents of Total Coliform Bacteria. This flush and sampling will be conducted by the Owner. If the test results do not show the presents of Bacteria, the water main will be put into service and the Contractor will be notified that the installation of Services may commence. If the sample taken shows the presence of Bacteria, then the main will be flushed again and a second sample will be taken. If the second sample does not show the presence of Bacteria, then the water main will be placed in service and the Contractor will be notified that the installation of Services may commence. If the second sample shows the presence of Bacteria, then the water main will require a re-chlorination and disinfection in accordance with AWWA standards and these Specifications until a sample is taken the does not show the presence of Bacteria.

#### **Developer Projects**

Upon the completion of a water main extension project including the passing of a pressure test administered by the Owner, and after the required As Built Drawing and Record of Service Spreadsheets have been submitted as described in the sections to follow, the water main will be flushed in accordance with AWWA standards and sampled for the presents of Bacteria. This flush and sampling will be conducted by the Owner. If the test results do not show the presence of Bacteria, the Developer will be contacted informing him that the sample has passed and the Maintenance Bond and Bill of Sale can be forwarded to the Owner for the activation of the

Water main. If the sample taken shows the presence of Bacteria, then the main will be flushed again and a second sample will be taken. If the second sample does not show the presence of Bacteria, the Developer will be contacted informing him that the sample has passed and the Maintenance Bond and Bill of Sale can be forwarded to the Owner for the activation of the water main. If the second sample shows the presence of Bacteria, then the water main will require a re-chlorination and disinfection in accordance with AWWA standards and these Specifications until an sample is taken the does not show the presence of Bacteria.

### **3. RECORD OF SERVICE SPREADSHEET**

Record of Service (ROS) information will be reported in tabular format. Service attributes previously recorded on individual Record of Service Spreadsheets will be required in the tabular format with exception to the service/meter pit sketch (i.e. contractor will still be required to report the location, date, connection type, depth, size, etc.). An example Record of Service spreadsheet is included within the appendix. VEOLIA will provide the contractor with a project-specific ROS template at the start of each project.

The ROS Spreadsheet is to be populated and submitted with GPS data, and remainder of close out documents to VEOLIA representative.

### **4. AS BUILT**

1. Prior to Final Acceptance of all work, Contractor will be required to furnish to the Company, for its approval, completed GPS as-built data showing the exact location of the installed facilities.
2. The as-built data should be provided using ArcGIS Online while adhering to the following specifications:
3. Contractors are responsible for the real time collection of the following assets. Underground assets must be collected prior to backfilling procedures. The contractor must meet centimeter accuracy for the collection of all assets. Please see Appendix B for specific collection requirements.
  - a. Curb Stop
  - b. Meter Pits
  - c. Corporation Stops (tap location)
  - d. Valves
  - e. Fittings
  - f. Hydrants
  - g. Hydrant Valves
  - h. Bell joints/water main

4. The As-Built is to be produced by the Contractor using GPS collection equipment as described below. The GPS As-Built Coordinates shall be collected and transmitted in “real time” and shall indicate the exact location and elevation of all facilities installed, prior to backfilling. Facilities shall include all pipe joints, fittings, valves, fire hydrants, hydrant valves, corporation stops, curb stops, blow-offs, air release valves, meter pits/vaults, and Water Main Points. Water Main points shall be collected at intervals no greater than fifty (50) feet.

The record of service spreadsheet shall be delivered to the company representative at the project closeout.

**The following equipment and licenses will be required for GPS Collection**

- GNSS Bluetooth Receiver (make and model agnostic) – must be capable of at least centimeter collection, and must be compatible with ArcGIS Field Maps. VEOLIA recommends Trimble R2 receiver (with Trimble Mobile Manager application) or EOS Arrow Gold receiver (with EOS Pro Tools applications)
- An annual RTK subscription for centimeter accuracy GPS collection. This license is \$1,000/year. More information regarding purchasing this subscription should be available from your GPS vendor
- iPad mobile devices with cellular data plan are recommended, however any mobile device can be used that supports ArcGIS Field Maps & connectivity to GNSS Bluetooth Receiver (and associated support applications)
- Contractors should download ArcGIS Field Maps (Collector support ended 12/31/21)
- ESRI ArcGIS Online “Creator” level ArcGIS Online License (±\$500 annual subscription) <https://www.esri.com/en-us/arcgis/products/arcgis-online/buy>

The contractor shall provide the ArcGIS Online Username to Veolia Pennsylvania GIS team once obtained from ESRI. The GIS team will add your company to the VEOLIA PA Contractors mapping group. Contact Veolia Pennsylvania to setup a training session if necessary. Training may be provided by VEOLIA or the equipment vendor. **\*\*Important: All points must be collected in real time (prior to backfilling) as the water network is installed\*\***

## **5. PROJECT INSPECTION & PUNCH LIST**

Upon the completion of a water main project and once the As Built Drawing and ROS sheets have been submitted to the Owner in the acceptable form a final project inspection will be conducted. This inspection will not commence until at a minimum the base paving has been installed on new water main installations or the pavement repair to finish grade has been placed on water main replacement or relocation projects. This inspection will be conducted by the Owner's Representatives. The inspection will verify that the water main was installed at the proper depth, verify that all valves, services, blow-offs, fire hydrants and all other facilities are installed in the proper location as shown on the plans provided by the owner, verify that all valves and service boxes are placed properly and make access to the associated valve or curb stop is possible, verify that all valve boxes, curb boxes and fire hydrants are installed to the proper height compared to the finish grade and verify that the stationing on the As Built and ROS sheets is correct.

If any items are found that need correction during the project inspection, a Punch List will be produced by the Owner and provided to the Developer if the project is a Developer project or the Contractor if the project is a Company Project.

**Developer Projects**, items listed on the Punch List must be corrected to the satisfaction of the Owner prior to acceptance of the project and activation of the water main and services. Once the Developer has addressed all the items on the Punch List, a follow up inspection will be conducted to verify that all items have been addressed and corrected. Once all the Punch List items have been corrected, the Developer will be contacted and informed to supply the Maintenance Bond and Bill of Sale in order to get the water main activated.

**Company Projects**, items listed on the Punch List must be corrected to the satisfaction of the Owner by the Contractor prior to the payment of the final invoice and release of retainage.

## **6. BILL OF SALE & MAINTENANCE BOND**

The current tariff requires the Developer to execute a "Bill of Sale" and a "Maintenance Bond" (for a period of two years at completion of the water system installation) for the newly installed water main and associated facilities. The "Bill of Sale" is to transfer the ownership of the installed water main, service lines and accessories in the public right-of-way or in a dedicated water utility easement to the water company. The "Maintenance Bond" is required as per Owner's Pennsylvania PUC Tariff effective October 28, 2015.

**APPENDIX A**  
**ASBESTOS CEMENT PIPE**  
**STANDARD OPERATING PROCEDURES**



**ASBESTOS CEMENT PIPE REPAIR,  
REMOVAL & DISPOSAL  
STANDARD OPERATING PROCEDURES**



# TABLE OF CONTENTS

Background & Purpose	65
Veolia Policy	67
Summary of U.S. EPA, State, & Local Requirements	67
Operations & Maintenance Program	68
Figure 1. Decision-Tree for ACP Management	69
Notification to EPA and State	69
Pipe Repairs	70
Tapping	70
Non-friable ACP	71
Removal & Disposal of ACP	71
Planned Project	72
Emergency Repair	72
Abandonment of ACP	72
Transportation of Waste ACP	73
Training	74
Record Keeping	75
Appendix 1 - Veolia recommended ACP work practice procedures	76
Appendix 2 - U.S. EPA Notification of demolition and renovation form	78
Appendix 3 - Internal VEOLIA documentation form for abandonment-in-place of ACP	79



## **BACKGROUND AND PURPOSE**

The purpose of the following procedures is to outline Veolia's policies, practices and procedures to comply with federal, state and local requirements associated with the management and disposal of asbestos cement pipe (ACP). This guidance is not a substitute for reading the regulations. Each employee who is responsible for handling ACP should review and understand the regulations and under what conditions and circumstances they may apply.

By way of background, ACP is a mixture of Portland cement and asbestos fibers and was commonly used in potable water main construction in North America from the 1940s until the 1960s, and was largely discontinued in the late 1970s. It is estimated that more than 400,000 miles of ACP are still in service throughout North America. The scope and extent of ACP in service today depends upon a number of factors, including the age of a community and its distribution and collection system, and whether the system provides/conveys drinking water or wastewater.

Within Veolia, the scope and extent of ACP also depends on the business segment. Veolia operates over 200 municipal water systems under public-private partnership agreements, and owns and operates 20 regulated water utilities. These operations are managed under two separate business segments, Contract Services and Regulated Business, respectively. The Regulated Business consists predominantly of drinking water systems. In contrast, Contract Services consists mostly of municipal wastewater treatment systems that are operated pursuant to contracts with our clients. Depending on the particular contract, Contract Services may or may not have responsibility for managing the distribution system.

Due to the nature of their services and contractual scope of work, Veolia employees within Contract Services are far less likely to encounter ACP as part of their daily responsibilities. In contrast, Veolia's Regulated companies own and operate the assets of their water plants, including the mains and distribution system. For these assets, Veolia is responsible for both repair and replacement of water mains, including any ACP in the network. As a result, field personnel employees within the Regulated Business unit who are responsible for transmission and distribution activities may encounter ACP on a more routine basis. However, even within Veolia's Regulated operations, the amount of ACP can vary significantly, ranging from less than one percent to over 50 percent of the total mains in service.

Some of these pipes are old and periodically need to be replaced and some are undersized and need to be upsized over time to meet the service demands. These actions may require all or part of the ACP system to be removed from service. Veolia no longer purchases or installs ACP within the distribution or collection systems.

Veolia's operations may encounter ACP periodically during emergency work to repair water main breaks and planned projects, such as new connection taps and pipe realignment or replacement. In responding to emergency water main breaks, it is not always known whether the pipe is ACP until the pipe is unearthed and repair work begun. Occasionally, entire 13 feet sections of ACP may need to be replaced where longitudinal cracks (a/k/a "blow-outs") are encountered. Repairs may also involve clean breaks (a/k/a "circle cracks") in which small sections of ACP less than 13 feet can be repaired with little or no disturbance to the ACP. The longstanding industry practice is to abandon-in-place ACP that is encountered in the field; as a general matter, such practice is neither inconsistent with nor prohibited by law.

Regardless of the circumstance, water service must be resumed as quickly as possible, which is critical for reasons involving community public health and safety, including providing water to hospitals and medical care facilities, nursing homes, and for fighting fires. Thus, it is important for VEOLIA employees to anticipate coming into contact with ACP during such emergency events, be properly trained, and employ appropriate work practices to reduce the potential health risks associated with handling the ACP.

The U.S. Environmental Protection Agency (EPA) has determined that asbestos, in an airborne condition, is a hazardous material and has established laws/guidelines for the handling and disposal of the material. Under the Clean Air Act, the Asbestos National Emission Standard for Hazardous Air Pollutants establishes requirements for the removal and disposal of regulated asbestos containing materials. 40 CFR Part 61, Subpart M ("Asbestos NESHAP"). The Occupational Safety and Health Administration (OSHA) also sets forth asbestos standards for construction found at 29 CFR 1926.1101. Additionally, many states have additional requirements that go beyond the federal requirements.

## **VEOLIA POLICY**

As stated in Veolia’s environmental charter, the Company seeks not only to achieve 100% compliance, but exceed legal requirements for maximum protection for human health and the environment.

In the case of ACP, this means to improve upon the industry practice of abandonment, by removing, where practicable, all ACP (friable and non-friable), and properly disposing of it or, alternatively, taking measures to minimize against future, uncontrolled exposure. The purpose of this policy is two-fold, (1) to minimize and reduce the potential harm to the environment and human health for future generations, and (2) to set forth practices and procedures to safeguard the health of VEOLIA employees.

This Asbestos Plan establishes procedures compliant with the legal requirements and the foregoing policy.

## **SUMMARY OF U.S. EPA, STATE, AND LOCAL REQUIREMENTS**

ACP is considered to be “Category II non-friable asbestos-containing material” (“ACM”), which is not regulated under the NESHAP when in its intact state. The term “friable” means material which, when dry, may be crumbled, pulverized or reduced to powder by hand pressure. If ACP is in good condition and remains in its non-friable state, it is not subject to the NESHAP.

For ACP to be considered non-friable it must be removed intact, and not crushed, cut, ground or pulverized, or otherwise made friable. If the ACP is in poor condition when unearthed or if during excavation it becomes crumbled, pulverized or reduced to powder or is removed in pieces, and the project involves at least 260 linear feet of such friable material (individually or aggregated with other projects over the course of the calendar year), it is covered by the NESHAP, and the following requirements apply:

- Notification to EPA and the State of the ACM removal activity. See below for more detail regarding the notification requirement. (40 CFR 61.145(b));
- Procedures for controlling asbestos emissions during removal, including adequately wetting the material, (40 CFR 61.145(c)), and having, licensed, trained personnel oversee the work.
- Procedures for handling asbestos-containing wastes prior to disposal, including keeping the material adequately wetted, containing the material to prevent releases and worker exposure, marking the containers and vehicles carrying the waste, creating waste shipment records, and disposing in a proper asbestos waste disposal landfill. (40 CFR 61.150).

### **Additional state and local requirements include:**

The safest way to handle ACP is to make sure the material stays in a non-friable condition and is wetted during any disturbance. Friable asbestos material will easily release fibers when crushed. Non-friable asbestos material has a solid matrix that holds the asbestos fibers together and will not allow asbestos fibers to release easily, unless mishandled, damaged, or in badly weathered condition.

Non-friable asbestos materials in good condition are exempt from the Asbestos NESHAP. Non-friable material that is removed for disposal, must be handled, transported, and disposed of in a way that prevents it from becoming friable and releasing asbestos fibers. For example, cutting, grinding or crushing ACP may cause it to become friable.

Note that even if ACP becomes friable during repairs or removal operations, if less than 260 linear feet of pipe is involved in the project, the NESHAP requirements do not apply. However, if it can be predicted based on operating experience that the total aggregate amount of regulated asbestos-containing material that will be disturbed by individual operations in a given water system over the course of a calendar year will equal at least 260 linear feet, the NESHAP standard applies to all of the individual repairs and planned projects. Therefore, it is important that your operation maintain a running log of the amount of ACP encountered and disturbed, and its condition, during each calendar year.

Note additionally that even if the NESHAP standard does not apply, OSHA worker protection requirements and state and local waste disposal requirements still apply.

### **OPERATIONS AND MAINTENANCE PROGRAM**

All VEOLIA business units or projects managing ACP must determine applicable state and local waste disposal requirements and any additional responsibilities for asbestos inspection and assessment activities.

**The following link provides additional information:**

<http://www.fedcenter.gov/resources/facilitytour/landfills/asbestos/>

## **FIGURE 1. DECISION-TREE FOR ACP MANAGEMENT**

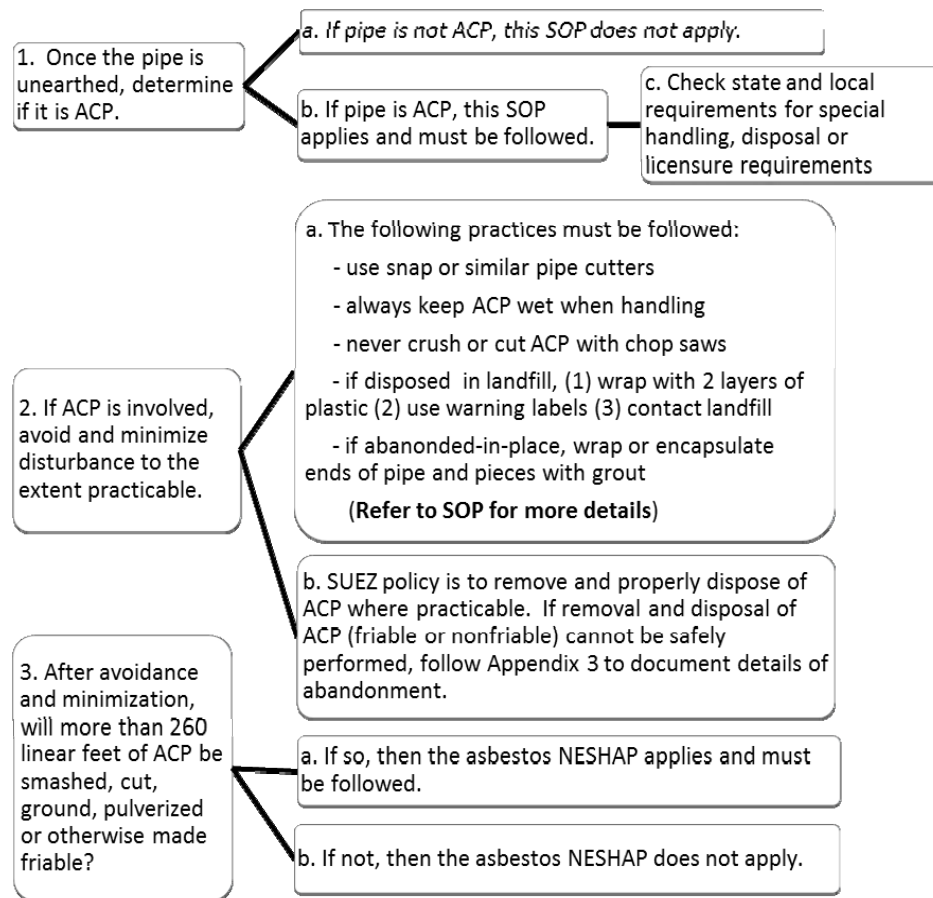

## **NOTIFICATION TO EPA AND STATE**

The NESHAP generally requires notification to the regional EPA administrator no less than 10 calendar days prior to beginning any activities that will remove or disturb at least 260 linear feet of regulated asbestos-containing material (“RACM”). Many states similarly require this advance notification. If a project will involve 260 linear feet or more of ACP that is damaged or that will otherwise become friable as a result of the project, both the regional EPA and the appropriate state agency must be notified at least 10 days prior to beginning the work. (40 CFR 61.145(b)(3)(i)).

Even if no individual project will exceed 260 linear feet of RACM, if it is predicted that a combined aggregate of at least 260 linear feet of RACM will be disturbed or removed in the same water system in individual nonscheduled operations over the course of a year (e.g., operations due to routine equipment failure but that do not constitute “emergencies”), the notice must be given at least 10 calendar days before the end of the prior calendar year. For example, if it is anticipated that the threshold will be exceeded in 2012, the notification must be given no later than December 21, 2011. (40 CFR 61.145(b)(3)(ii)).

For “emergency operations,” which are those that result from a sudden, unexpected event (such as a water main break) and that would impose an unreasonable financial burden or present a safety or public health hazard if not immediately attended to, if the 260 linear foot threshold is exceeded, the notification must be given as soon as possible, but no later than the next working day. (40 CFR 61.145(b)(3)(iii)).

If, based on past experience, your system has the potential to exceed the NESHAP threshold, including the potential for equipment failure or accidental crushing, it is prudent to file a “protective” notification with EPA. Note, however, that such notification to EPA will trigger compliance with other NESHAP provisions (e.g., emission control under 40 CFR 61.145(c) and waste disposal and record keeping under 61.150(b)) for all subsequent projects involving ACP. A supplemental notification to EPA can be provided if it is later determined that the threshold will not be exceeded during the year.

The EPA notification form is included in Appendix 2.

## **PIPE REPAIRS**

1. Prior to performing any repair work on ACP, you must
  - a. Inspect the pipe to determine whether it is friable; and
  - b. Wet down thoroughly the portion of piping to be worked on using wetting agent such as amended water containing a surfactant agent that improves the water’s ability to penetrate and saturate the material. EPA recommends the use of a 50:50 mixture of polyoxyethylene ester and polyoxyethylene ether, or the equivalent, in a 0.16 percent solution (1 ounce to 5 gallons) of water. Surfactants to make wetting agent are commercially available.
  - c. Wetting agents may be applied with garden sprayers or a hose with an attached dispenser. Wetting agent must be sprayed directly on the area of piping to be worked on.
2. At no time shall it be permissible to cut, bevel, file, demolish, or sand ACP with motorized, power driven tools or equipment. Only reed or snap type pipe cutters and hand operated tools may be used to perform such activities.
3. Wash all tools and equipment with clean water before removing from the trench.
4. Employees shall not eat, drink, smoke, chew tobacco or gum, or apply cosmetics in the immediate area while performing any work on ACP.

## **TAPPING**

All tapping operations performed on ACP must be accomplished with an enclosed pressurized wet tapping machine. Such machines shall be thoroughly flushed clean with water upon completion.

## **NON-FRIABLE ACP**

If ACP is in good condition and remains in its non-friable state, it is not subject to the NESHAP. Some states impose more stringent requirements and require removed ACP to be disposed at an asbestos authorized landfill. State and local authorities must be contacted to determine what additional management (e.g., using licensed or certified asbestos professionals) and disposal requirements, if any, may exist. Additionally, the landfill must be notified in advance of any disposal of ACP (friable or non-friable).

## **REMOVAL AND DISPOSAL OF ACP**

ACP that is in poor condition, badly damaged or weathered (e.g., longitudinal crack), cut or broken ends of ACP, and small pieces ACP (i.e., those caused by repairing a collar or preparing the ACP ends to accept joints), should be removed and disposed of as friable ACP. ACP ends or sections shall NOT be purposefully crushed and left in place. Any sections of ACP that are crushed or otherwise caused to become friable during work should be removed and properly disposed as friable. Alternatively, as provided below, for emergency repairs, broken pieces of ACP may be grouted in-place within an intact pipe to encapsulate and stabilize the material within the excavation.

All projects involving the removal and disposal of ACP, whether friable or not, must adhere to the following procedures:

1. Only employees properly trained in asbestos handling and removal shall be allowed to handle and remove friable asbestos materials.
2. Thoroughly wet the material as described above under "Pipe Repairs".
3. Keep the material wet while you remove it. Wetting prevents fiber migration during removal.
4. All waste ACP shall be placed in leak tight containers or wrapped and sealed in two layers of 6 mil polyethylene plastic sheeting (seams sealed with duct tape) with a warning statement "DANGER ASBESTOS-CONTAINING MATERIAL". The asbestos-containing waste material (ACWM) must remain wet until disposed of at a landfill authorized to handle asbestos waste.
5. State and local requirements must also be checked to determine whether specific license or certifications apply to your project.

Although EPA does not require a licensed asbestos abatement contractor, some states such as New Jersey, require OSHA Class II certified workers to remove all friable asbestos materials.

It is recommended that when entering into a contract with a licensed asbestos contractor for any repair or removal of ACP, VEOLIA as the generator (owner/operator of the site) should assess and confirm that the contractor properly handles, transports and disposes of the ACP waste.

This SOP does not require any project to expose, disturb, or remove sections of ACP that would not otherwise be unearthed or disturbed as part of the project (e.g., planned realignment project).

## **PLANNED PROJECT**

As part of any planned project (e.g., pipe replacement, realignment, rehabilitation, tapping), all ACP that is unearthed and exposed must be carefully inspected to determine its condition and whether it is friable or not. All friable ACP that is encountered during a planned project must be properly removed and disposed. Any such project where friable ACP cannot be practicably removed and must be abandoned-in-place, must follow the abandonment procedures below.

## **EMERGENCY REPAIR**

Emergency main leak repairs (and similar emergency activities) may or may not involve friable ACP. Once the pipe is excavated, it must carefully inspected to determine its condition and whether it is friable or not. Emergency repairs to ACP often involve crumbled or broken pieces of ACP. Ends of broken ACP may also be friable.

ACP that is broken and or becomes crumbled, pulverized, or reduced to powder during the project is friable and must be managed according to the procedures herein. If removal and disposal is not practicable during emergency repairs, ACP (whether friable or non-friable) may be abandoned-in-place, provided the abandonment procedures below are followed.

## **ABANDONMENT OF ACP<sup>1</sup>**

If sections and pieces of ACP cannot be practicably or safely removed or for other compelling reasons must be left in the ground and abandoned-in-place, employees shall inspect the visible sections that remain to assess their condition and whether they are friable or not.

Any project where ACP is abandoned-in-place must adhere to the following:

1. Any abandoned ACP shall be maintained safely below final grade. Depth of abandonment may vary depending upon the geographic location and local standards applicable to pipe emplacement, which is largely dependent upon the frost line. In no event, shall ACP be abandoned less than three feet below grade.
2. Except in the case of emergency repairs, abandonment must receive prior authorization from the Division or General Manager, with notification to the Director of Compliance.
3. All friable ACP (including small pieces) must be stabilized with grout or similar cementitious material or encapsulating any pieces within an intact pipe and sealing the ends to prevent water from seeping into the abandoned pipe.
4. You MUST document all abandoned-in-place ACP using the attached form "Internal VEOLIA documentation form for abandonment-in-place of ACP" (Appendix 3).

<sup>1</sup> It is important to check your state laws and/or discuss with state and local authorities any limitations on the abandonment of ACP. Some states have special waste disposal requirements for asbestos materials, which may require asbestos to be disposed of in an approved landfill.



The intent in having such a documentation requirement is to ensure that the existence of the abandoned ACP is known to both future property owners and utility workers who may conduct activity that could disturb the abandoned ACP.

In cases where the ACP being abandoned runs under a public right-of-way, such as a street, sidewalk or other public use, the following steps should be used to ensure adequate notification:

1. Determine if the right-of-way in question has designated lot and blocks. If a lot and block designation does exist, then normal deed notice procedure, detailing the risks of exposure and responsible party contact information, can then be followed.
2. If no lot and block designation exists, then:
  - a) Written notice should be provided to the agency (Federal, state, county or municipal) responsible for oversight of the given right-of-way, and the relevant state department of labor or health.
  - b) This notice should outline the exposure risks associated with disturbance of the abandoned-in-place ACP.
  - c) Include the name, address and business telephone number of the person/agency responsible for oversight of the repair project.

Regardless of the type of notice required, the agency or company that owns or is responsible for the pipe that is being repaired should ensure that the extent of abandoned-in-place ACP is identified on the electronic and/or hard-copy map of the pipe system used by the agency or company. The mapping should conform to the specifications for Right-of-Way Plans found in the pertinent DOT CADD Standards Manual.

As provided below, records **MUST** be maintained to document the size of small segments of friable ACP or portions thereof abandoned-in-place to keep track of the potential NESHAP threshold of 260 linear feet.

### **TRANSPORTATION OF WASTE ACP**

The transportation of ACP for disposal shall be in accordance with all federal and state requirements, including the following:

1. Registered solid waste vehicles must be used for the transportation of ACP and any solid waste containing asbestos, if and as required by state requirements. All vehicles shall be designed to prevent any spillage or leakage or emissions.
2. No transporter shall transport ACP unless such waste is properly packaged in accordance with 40 C.F.R. 61.150 and 49 CFR Parts 171-178 (if applicable).
3. The ACP shall be transported in a manner that prevents the rupture of the asbestos containers in loading, transport, and unloading operations.
4. Once collected, ACP shall be transported directly from the point of generation to the solid waste landfill or transfer station permitted to receive such wastes.
5. There shall be no visible air emissions during loading, transporting, or unloading operations.

## **TRAINING**

Any employee working with or repairing ACP shall have prior instruction on the following:

- a. How to identify asbestos cement (AC) pipe.
- b. The health effects associated with asbestos exposure.
- c. The relationship between smoking and asbestos exposure.
- d. The nature of operations that could result in asbestos exposure.
- e. Work practices and exposure control methods.
- f. Waste disposal procedures.
- g. Purpose, proper use, fitting instructions and limitations of respirators.
- h. Medical surveillance program requirements.
- i. The contents of the OSHA asbestos standard, including appendices.
- j. The names, addresses, and phone numbers regarding public health organizations that provide information concerning smoking cessation.
- k. The requirements for posting signs and affixing labels and the meaning of same

The following EPA link provides information regarding training providers and approved courses:  
<http://www.epa.gov/asbestos/pubs/location.html>

Be certain that any selected training is certified for both EPA and OSHA training. The OSHA asbestos obligations can be found at the following link:  
[http://www.osha.gov/pls/oshaweb/owadisp.show\\_document?p\\_id=10862&p\\_table=STANDARDS](http://www.osha.gov/pls/oshaweb/owadisp.show_document?p_id=10862&p_table=STANDARDS)

---

## **RECORD KEEPING**

Each VEOLIA business unit must maintain accurate records of the following:

- a. Employee training records. (Permanent retention)
- b. Laboratory data used to support this procedure which shows that asbestos is not being released at levels at or above the (PEL) in accordance with expected operating conditions and procedures. (Permanent retention)
- c. Measurements taken, if any, to monitor employee exposure to asbestos. (30- year retention)
- d. The date, location and nature of the project (e.g., repair of blow-out, circle crack, replacement), condition of ACP when excavated, size of pipe repaired/removed, whether the ACP was abandoned-in-place or disposed off-site, and any details pertaining to disposal. (See Appendix 3)

The following example illustrates how records may be maintained for purposes of determining the applicability of NESHAP.

*Hypothetical: In January, Water System Y, responds to three water main breaks (one circle crack and two blow-outs) and is also undertaking a planned realignment project involving 300 feet of ACP. The repaired circle crack involved two ends that were inadvertently broken during repair; otherwise the pipe was in good condition (estimated two feet of friable ACP disturbed). The blow-outs involved two 13-foot sections that were completely replaced (total of 26 feet of friable ACP disturbed). In the case of the realignment project, only 40 feet of the 2000 feet of ACP is unearthed and disturbed during construction. The 40 feet of ACP is determined to be friable and removed for disposal. For January, the Project would have disturbed a total of 68 feet of friable ACP (the sum of two, 26, and 40 feet of friable ACP). Since this project involves the disturbance of less than 260 feet of friable ACP, the NESHAP does not apply. If, however, in March, the Water System unearths and disturbs 200 linear feet of friable ACP, the NESHAP requirements are triggered ( $200 + 68 = 268$  feet) for the calendar year and will apply to all ACP repairs and projects during that year Asbestos Cement Pipe SOP Appendix 1*

# APPENDIX 1

## VEOLIA RECOMMENDED ASBESTOS CEMENT PIPE WORK PRACTICE PROCEDURES

This work activity is identified as a Class II asbestos removal activity by OSHA's Subpart Z, 29 CFR 1926.1101.

The following procedures are to be followed to protect employees and the public when working with asbestos cement pipe. The following summarizes many of the obligations of 29 C.F.R. 1926.1101, but is not a substitute for a full understanding and application of those requirements. All work must be done pursuant to 29 CFR 1926.1101 and any other applicable OSHA regulation (personal protective equipment, respiratory protection, etc.) Full compliance will prevent any employee exposure to airborne fiber concentrations levels above the permissible exposure limit of 0.1 fibers per cubic centimeter of air as an eight hour TWA as required by OSHA or exposure in excess of the excursion limit of 1.0 fiber per cubic centimeter of air as a 30 minute TWA.

### **REQUIRED PERSONAL PROTECTIVE EQUIPMENT**

In circumstances where any employee may be exposed to airborne asbestos in excess of PELs, employees will be provided with protective clothing such as coveralls or similar whole-body clothing, hard hats, rubber gloves, and rubber safety toed hip boots. Respirators also will be required when asbestos will not be removed in a substantially intact state, where wet methods will not be used, or any other situation where a risk exists that employees could be exposed to asbestos fibers above the PELs if they were not wearing respirators. Any employee who wears a respirator will be subject to annual medical evaluation and fit testing.

In situations where employees have no risk of exposure to asbestos above the PELs (because, e.g., we have determined using the process contained in the asbestos regulation that employee exposure during the work is expected to be consistently below the PELs), the employee will be provided with the appropriate personal protective equipment for the circumstances.

Before beginning work on ACP, qualified personnel must conduct an exposure assessment and document the assessment. Once the assessment has been conducted, establish a regulated work area (RWA) using barricade tape and limit access to the area to authorized personnel only. Post asbestos-warning signs at the RWA entry point. Establish a waste load-out area attached to the RWA (applicable to non-emergency situations).

### **APPROVED CUTTING PROCEDURES**

Hydraulic Snap Pipe Cutters, Ratchet Snap Pipe Cutters, hydraulic/pneumatic pipe chain saw with continuous water bath.

Note: Similarly, under no circumstances will compressed air be used to remove asbestos cement pipe debris. Asbestos Cement Pipe SOP Appendix 1

**PROCEDURES FOR CUTTING, TAPPING OR INSTALLING REPAIR CLAMPS**

1. Excavate around the asbestos cement pipe a sufficient distance to assure adequate tool clearance in the area to be cut. Care must be taken to avoid any abrasion to the pipe. Machine excavate to expose ACP pipe. Hand excavate areas under pipe where cuts/breaks are planned.
2. Put on the required protective equipment and have sufficient water available before entering the trench to begin work.
3. Clean and wash with water the surface area of the pipe to be cut tapped or where a repair clamp is to be installed. Continue applying water until the cleaning process is complete.
4. Continue to use water during the cutting, tapping or the process of installing a leak repair clamp until the process is complete.
5. When the job is complete wash off all the tools, equipment, and rubber boots with water.

**ASBESTOS PIPE REMOVAL AND CONTAINERIZATION PROCEDURES**

1. Before any asbestos cement pipe is transported it must be wrapped with two layers of 6mil clear polyethylene wrapping. Seal all seams with duct tape. Schedule for disposal.
2. Transport to an authorized landfill or Veolia pipe yard and unload in the designated area. The designated area shall be labeled as follows:

*DANGER Contains Asbestos fibers Avoid Creating Dust Cancer & Lung Disease Hazard*

**Please note, as referenced in the earlier section on NESHP that the class II work**

# APPENDIX 2

## U.S. EPA NOTIFICATION OF DEMOLITION AND RENOVATION FORM

Link: <http://www.epa.gov/region1/enforcement/asbestos/pdfs/AsbestosNotificationFormFF.pdf>

### U.S. EPA NOTIFICATION OF DEMOLITION AND RENOVATION

Page 1 of 2

Operator Project #	Postmark	Date Received	Notification #				
<b>I. Type of Notification (check one):</b> <input type="checkbox"/> Original <input type="checkbox"/> Revised <input type="checkbox"/> Canceled							
<b>II. Facility Description</b>							
Building Name: _____							
Address: _____							
City: _____		State: _____	Zip Code: _____	Country: _____			
Site Location: _____							
Building Size (square feet): _____		# of Floors: _____		Age in Years: _____			
Present Use: _____				Prior Use: _____			
<b>III. Type of Operation (check one):</b> <input type="checkbox"/> Demo <input type="checkbox"/> Ordered Demo <input type="checkbox"/> Renovation <input type="checkbox"/> Emergency Renovation <input type="checkbox"/> Fire Training							
<b>IV. Is Asbestos Present? (check one):</b> <input type="checkbox"/> Yes <input type="checkbox"/> No							
<b>V. Facility Information</b>							
Owner Name: _____							
Address: _____							
City: _____		State: _____	Zip Code: _____				
Contact: _____		Telephone: ( ) _____	Fax: _____				
Removal Contractor Name: _____							
Address: _____							
City: _____		State: _____	Zip Code: _____				
Contact: _____		Telephone: ( ) _____	Fax: _____				
Other Operator (demolition/general): _____							
Address: _____							
City: _____		State: _____	Zip Code: _____				
Contact: _____		Telephone: ( ) _____	Fax: _____				
<b>VI. Procedure, including analytical methods, employed to detect the presence of and to estimate the quantity of RACM and Category I and Category II non-friable ACM:</b>							
<b>VII. Approximate Amount of Asbestos Materials:</b>							
	RACM to be Removed	Non-friable Asbestos Material to be Removed		Non-friable Asbestos Material NOT to be Removed			
		Category I	Category II	Category I	Category II		
Pipes (linear feet)							
Surface Area (square feet)							
Facility Components (cubic feet)							
<b>VIII. Scheduled Dates Demolition or Renovation:</b> Start: _____ Complete: _____							
<b>IX. Dates for Asbestos Removal (MM/DD/YY)</b> Start: _____ Complete: _____							
Days of the Week:	Monday	Tuesday	Wednesday	Thursday	Friday	Saturday	Sunday
Hours of Operation:							

# APPENDIX 3

## INTERNAL VEOLIA DOCUMENTATION FORM FOR ABANDONMENT-IN-PLACE OF ACP

**Internal Veolia Documentation Form  
For Abandonment-In-Place of ACP**

Date \_\_\_\_\_

Business Unit / Project Name \_\_\_\_\_

1. Check One: Planned \_\_\_ Emergency \_\_\_

2. Provide Description Below.

3. Describe Location (provide lot and block information, GPS coordinates, if available, address, street intersection, etc.).

4. Amount of ACP abandoned-in-place (in feet): \_\_\_\_\_

5. Amount of friable ACP abandoned, if any (in feet): \_\_\_\_\_

6. How will data be recorded/available to public (describe database or map, etc.)?

\_\_\_\_\_

\_\_\_\_\_

**Photographs MUST be Attached**

## APPENDIX B TABLE OF CONTENTS

<b>2024 TYPICAL DRAWINGS &amp; DETAILS</b>	<b>1-34</b>
TYPICAL CROSS SECTION FOR CONCRETE RESTORATION	1
TRENCH RESTORATION DETAIL – AREAS OUTSIDE PAVEMENT	2
TRENCH RESTORATION DETAIL – EXISTING & PROPOSED PAVED AREAS	3
THRUST BLOCKING	4
THRUST BLOCK FOR VERTICAL BENDS	5
THRUST BLOCK NOTES	6
THRUST BLOCK SIZING TABLE	7
THRUST BLOCK DEAD END & BEND	8
THRUST BLOCK TEE	9
TYPICAL VALVE BOX INSTALLATION	10
TYPICAL FIRE HYDRANT INSTALLATION	11
TYPICAL 2" BLOWOFF INSTALLATION FOR 4" & LARGER MAIN	12
TYPICAL 2" BLOWOFF INSTALLATION FOR 2" MAIN	13
TYPICAL ¾" SERVICE INSTALLATION	14
TYPICAL 1" SERVICE INSTALLATION DETAIL FOR 8" & LARGER MAIN	15
LONG SIDE SERVICE NON-FIRE SERVICE – ¾" / FIRE SERVICE – 1"	16
TYPICAL ⅝" X ¾" METER PIT INSTALLATION	17
*TYPICAL ⅝" X ¾" METER W/ ¾" PRV METER PIT	18
TYPICAL ¾" METER PIT INSTALLATION	19
¾" UFR PRV METER PIT	20
TYPICAL 1" METER PIT SETTING	21
TYPICAL 1-½" METER PIT SETTING INSTALLATION	22
TYPICAL 2" METRON SPECTRUM 130-D W. SPL13017 SPOOL METER PIT SETTER INSTALLATION	23
TYPICAL FS/DS VAULT (FOR REFERENCE ONLY – NOT FOR CONSTRUCTION)	24
TYPICAL FIRE SERVICE VAULT (FOR REFERENCE ONLY – NOT FOR CONSTRUCTION)	25
PROPOSED DOMESTIC / FIRE FITTINGS ON EXISTING WATERMAIN STUB	26
TYPICAL LEAK DETECTION METER PIT INSTALLATION	27
ECLIPSE NO. 88 SAMPLING STATION INFORMATION & DETAILS	28-31
*TYPICAL WATERMAIN / STORMWATER CROSSINGS	32
*TYPICAL WATERMAIN / SANITARY SEWER CROSSINGS	33
*TYPICAL WATERMAIN / HIGH PRESSURE GAS CROSSINGS	34
<b>2024 FORMS, TEMPLATES, &amp; SUPPLEMENTAL INFORMATION</b>	<b>35-72</b>
2024 APPROVED MATERIAL LIST	35-36
METER PIT PART NUMBER SPECIFICATION TABLE	37
DEVELOPER PROJECT PRELIMINARY COST SUMMARY EXAMPLE	38
DEVELOPER PROJECT FINAL COST SUMMARY EXAMPLE	39
PROJECT BID FORM EXAMPLE	40-41
CHANGE ORDER REQUEST FORM	42
RECORD OF SERVICE SPREADSHEET EXAMPLE	43
WEEKLY PROGRESS REPORT BLANK	44
EXAMPLE PAYMENT SUBMISSION DOCUMENTS (AIA DOCUMENT G702 & G703, TASK ORDER, RELEASE OF LIEN)	45-48
*2024 GPS DIRECTIONS	49-55
REQUIRED STEPS FOR DEVELOPER PROJECTS	56-72



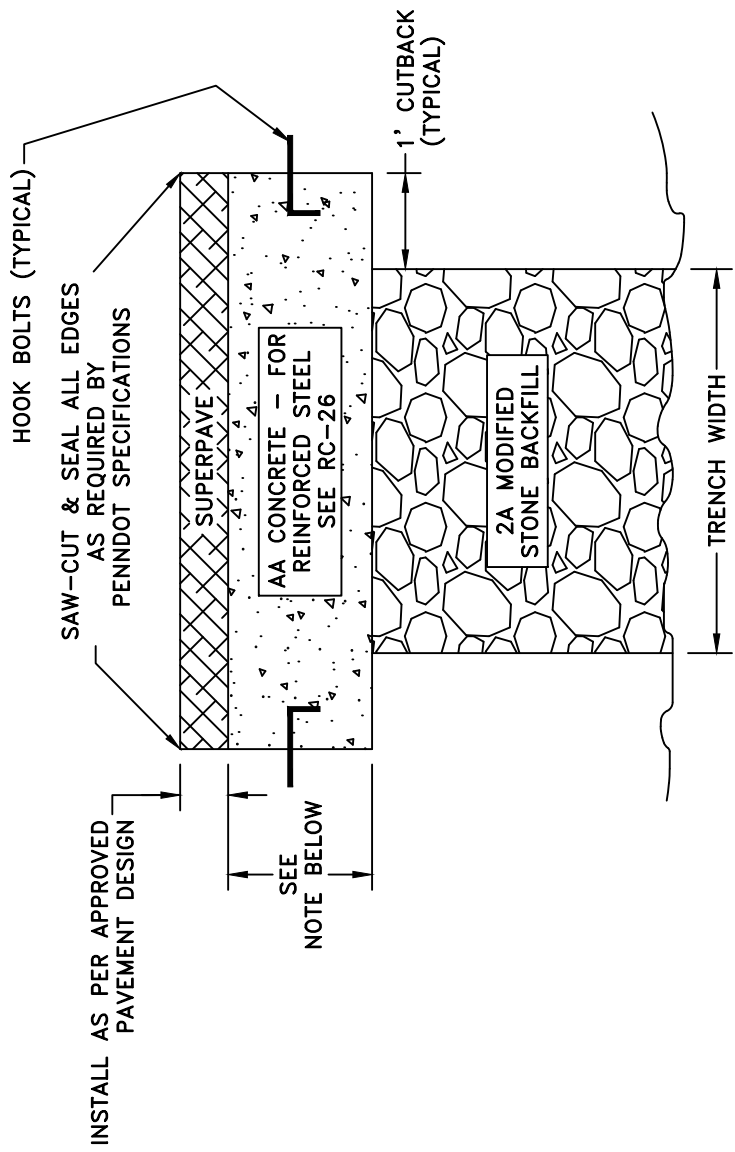

## CONCRETE REPLACEMENT

**Note:** The replacement pavement shall consist of 4 day AA concrete equal in depth to the original concrete pavement or to a depth of 8 inches, whichever is greater.

 <p style="font-size: small; text-align: center;">VEOLIA WATER PENNSYLVANIA 6310 ALLENTOWN BLVD HARRISBURG, PENNSYLVANIA 17112</p>		<p><b>TYPICAL CROSS SECTION FOR CONCRETE RESTORATION</b></p>	
DWG NAME	TYPICAL CROSS SECTION FOR CONCRETE RESTORATION		
DRAWN BY	SCALE	DATE	CAD FILE NAME
DRP	N.T.S.	11-27-17	SWPA-TYP DWG
<p style="font-size: x-small;">THIS DRAWING IS PROVIDED BY VEOLIA WATER PENNSYLVANIA FOR DISPLAY AND IS SUBJECT TO CHANGE WITHOUT NOTICE. NO CLAIMS, EITHER REAL OR ASSUMED AS TO ABSOLUTE OR RELATIVE ACCURACY OR PRECISION OF ANY DATA CONTAINED HEREIN ARE MADE BY VEOLIA WATER PENNSYLVANIA, NOR WILL THE COMPANY BE HELD RESPONSIBLE FOR ANY USE OF THIS DOCUMENT FOR PURPOSES OTHER THAN WHICH IT IS INTENDED.</p>			
NO.	REVISION	DATE	

- 6" SCREENED TOPSOIL
- GRASS SEED (OR SOD)
- STARTER FERTILIZER
- STRAW MATTING (OR LOOSE STRAW MULCH)

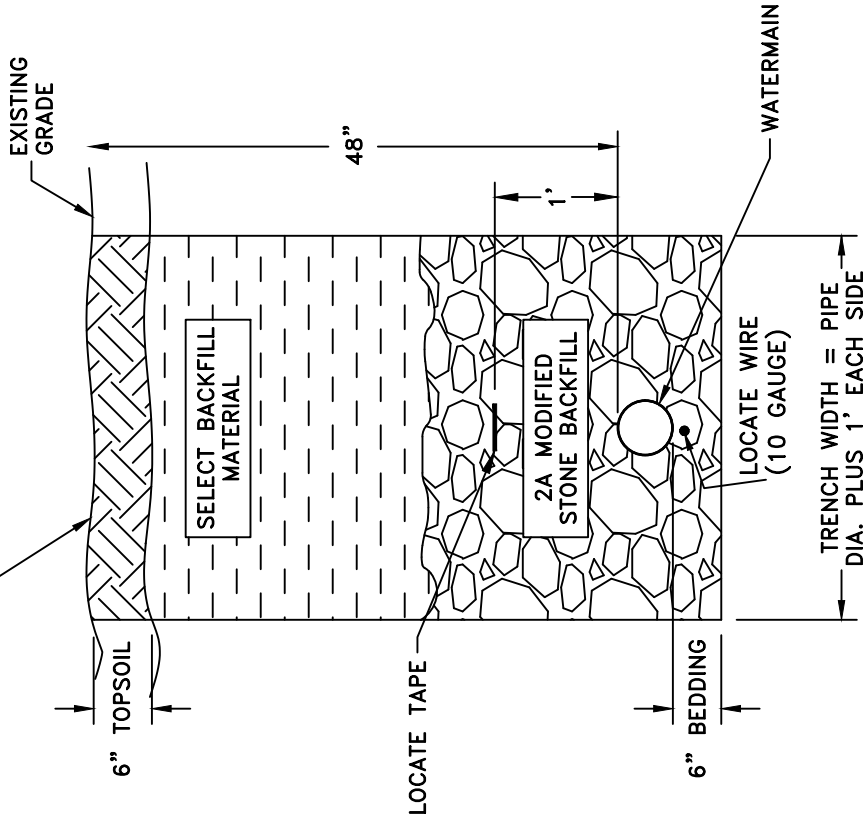

THIS DRAWING IS PROVIDED BY VEOLIA WATER PENNSYLVANIA FOR DISPLAY AND IS SUBJECT TO CHANGE WITHOUT NOTICE. NO CLAIMS, EITHER REAL OR ASSUMED AS TO ABSOLUTE OR RELATIVE ACCURACY OR PRECISION OF ANY DATA CONTAINED HEREIN ARE MADE BY VEOLIA WATER PENNSYLVANIA, NOR WILL THE COMPANY BE HELD RESPONSIBLE FOR ANY USE OF THIS DOCUMENT FOR PURPOSES OTHER THAN WHICH IT IS INTENDED.

NO.	REVISION	DATE

VEOLIA WATER PENNSYLVANIA  
6310 ALLENTOWN BLVD  
HARRISBURG, PENNSYLVANIA 17112

DWG NAME  
TRENCH RESTORATION DETAIL  
AREAS OUTSIDE PAVEMENT

DRAWN BY DRP	SCALE N.T.S.	DATE 12-4-19	CAD FILE NAME SWPA-TYP DWG
-----------------	-----------------	-----------------	-------------------------------

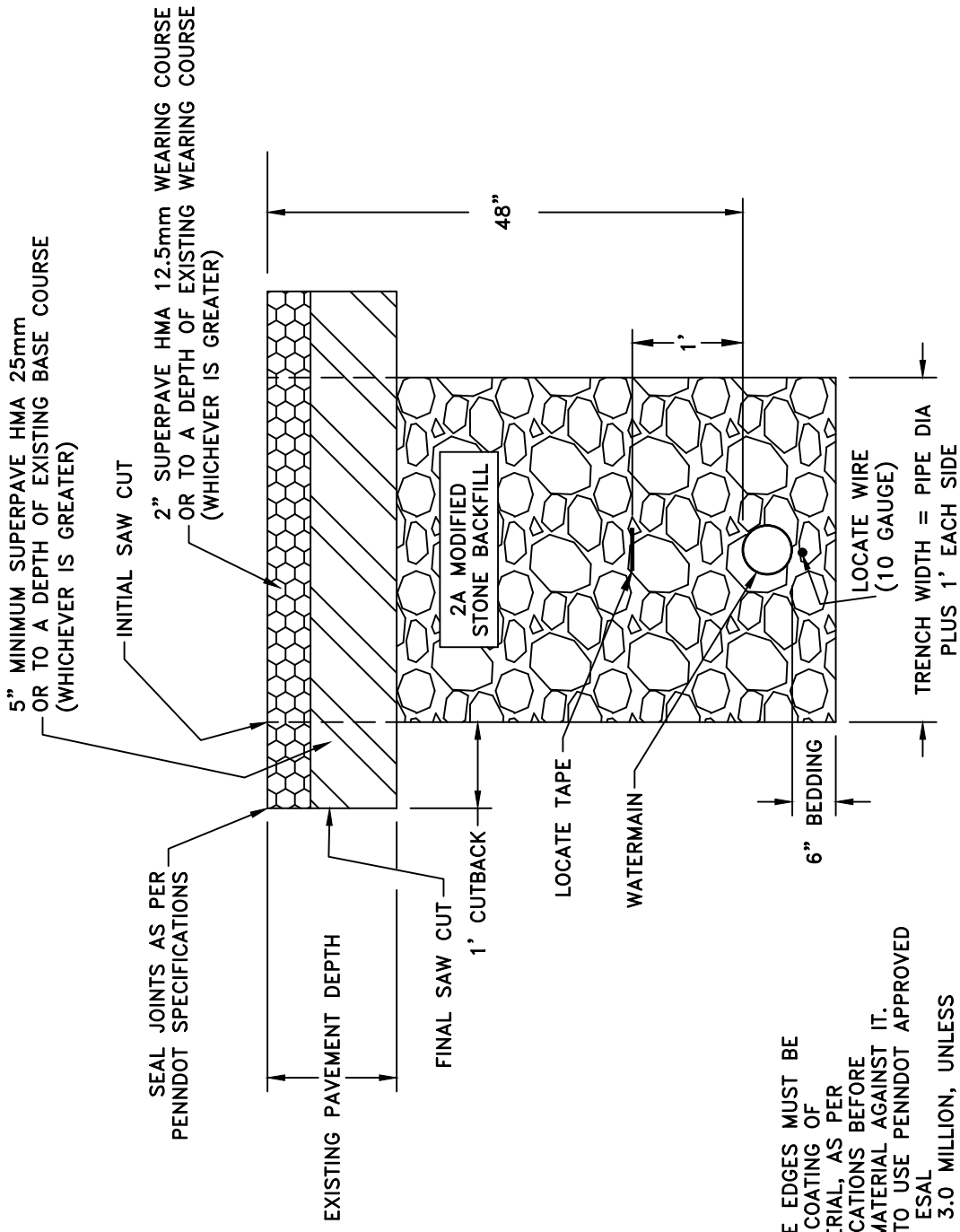

5" MINIMUM SUPERPAVE HMA 25mm  
OR TO A DEPTH OF EXISTING BASE COURSE  
(WHICHEVER IS GREATER)

INITIAL SAW CUT

2" SUPERPAVE HMA 12.5mm WEARING COURSE  
OR TO A DEPTH OF EXISTING WEARING COURSE  
(WHICHEVER IS GREATER)

48"

2A MODIFIED  
STONE BACKFILL

LOCATE WIRE  
(10 GAUGE)

TRENCH WIDTH = PIPE DIA  
PLUS 1' EACH SIDE

6" BEDDING

SEAL JOINTS AS PER  
PENNDOT SPECIFICATIONS

EXISTING PAVEMENT DEPTH

FINAL SAW CUT  
1' CUTBACK

LOCATE TAPE

WATERMAIN

**NOTES:**

- 1) EXPOSED VERTICLE EDGES MUST BE PAINTED WITH A COATING OF BITUMINOUS MATERIAL, AS PER PENNDOT SPECIFICATIONS BEFORE PLACING FRESH MATERIAL AGAINST IT.
- 2) SUPERPAVE HMA TO USE PENNDOT APPROVED ASPHALT BINDER, ESAL RANGE 0.3 TO < 3.0 MILLION, UNLESS OTHERWISE SPECIFIED.
- 3) TRENCH BACKFILL TO ATTAIN 100% COMPACTION.

DWG NAME

TRENCH RESTORATION DETAIL  
FOR EXISTING AND PROPOSED PAVED AREAS



VEOLIA WATER PENNSYLVANIA  
6310 ALLENTOWN BLVD  
HARRISBURG, PENNSYLVANIA 17112

DATE

REVISION

NO.

DRAWN BY

DRP

SCALE

N.T.S.

DATE

11-27-17

CAD FILE NAME

SWPA-TYP DWG

**NOTES;**

- 1) ALL CONCRETE SHALL HAVE A MINIMUM TWENTY-EIGHT (28) DAY COMPRESSIVE STRENGTH OF NOT LESS THAN 3000psi
- 2) THRUST BLOCKING SHALL BE PLACED BETWEEN UNDISTURBED EARTH AND THE FITTING TO BE ANCHORED.
- 3) THRUST BLOCKING SHALL BE PLACED SO THAT THE PIPE AND FITTING JOINTS WILL BE ACCESSIBLE TO REPAIRS.

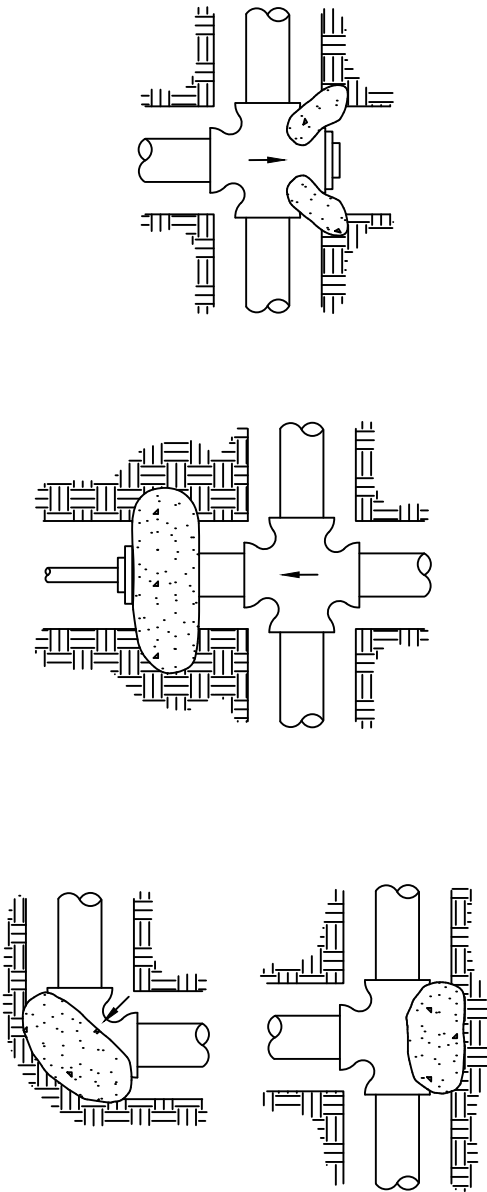

TYPICAL THRUST BLOCKING

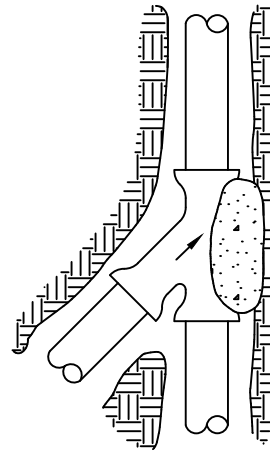
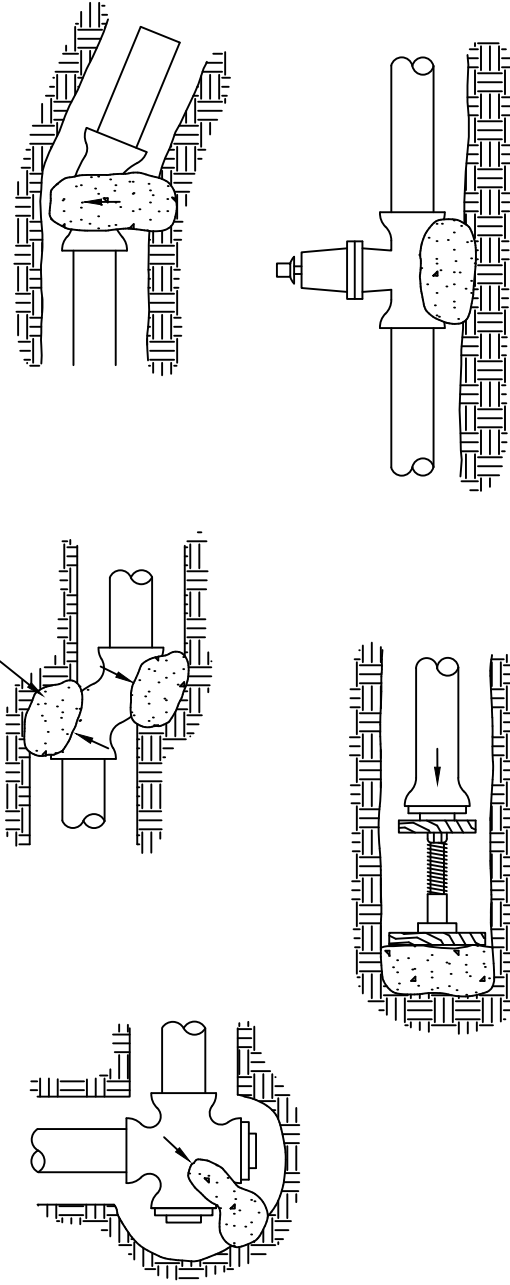

NO.	REVISION	DATE

  
**VEOLIA WATER PENNSYLVANIA**  
 6310 ALLENTOWN BLVD  
 HARRISBURG, PENNSYLVANIA 17112

DWG NAME		THRUST BLOCKING	
DRAWN BY	SCALE	DATE	CAD FILE NAME
DRP	N.T.S.	11-27-17	SWPA-TYP DWG

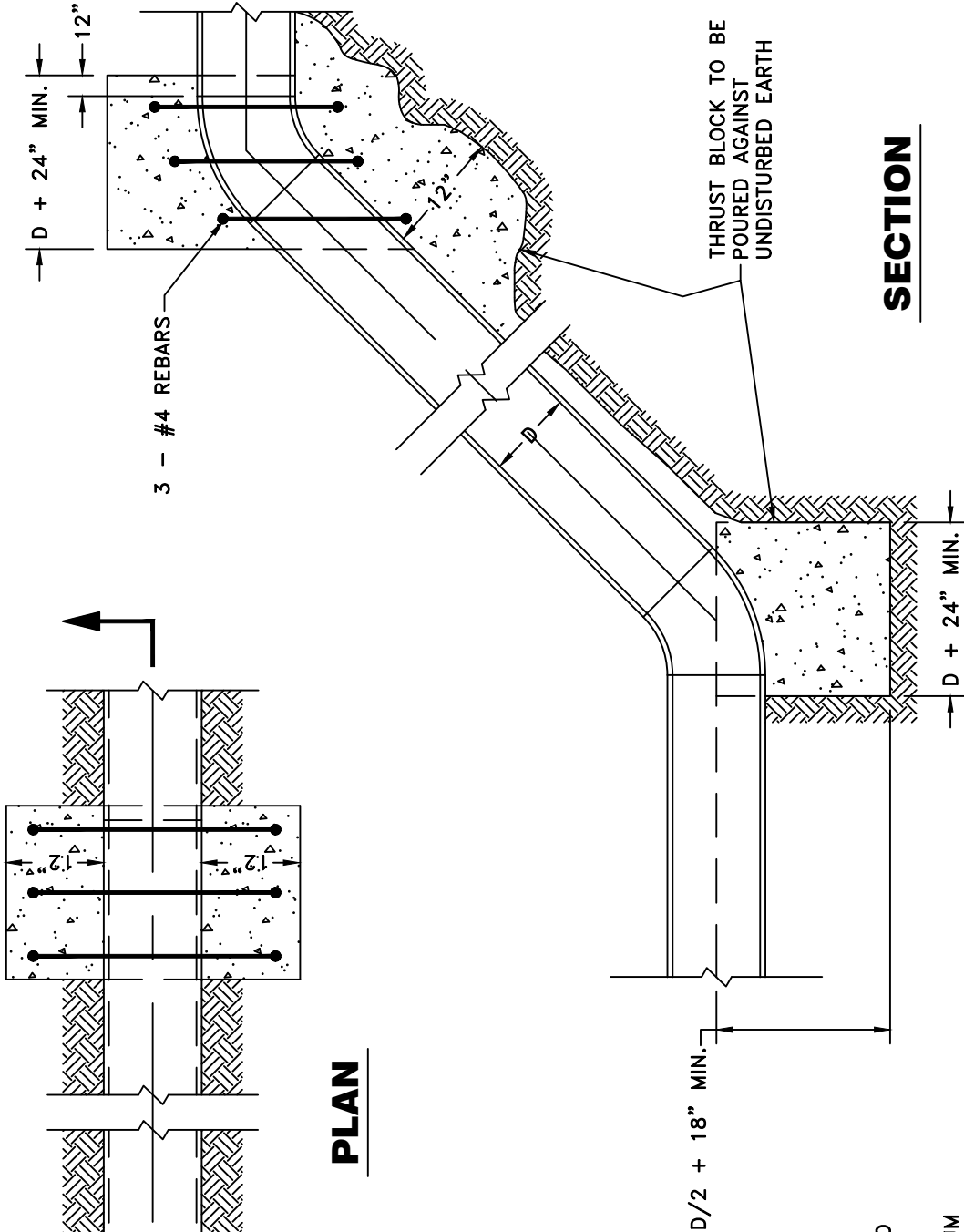

**PLAN**

**SECTION**

**NOTES:**

- 1) THRUST BLOCK DETAILS APPLY TO ALL PIPE INCLUDING CONCRETE, DUCTILE IRON, STEEL AND PVC.
- 2) CONCRETE SHALL HAVE A MINIMUM STRENGTH OF 3,000 PSI AT 28 DAYS AND SLUMP < 4".

THIS DRAWING IS PROVIDED BY VEOLIA WATER PENNSYLVANIA FOR DISPLAY AND IS SUBJECT TO CHANGE WITHOUT NOTICE. NO CLAIMS, EITHER REAL OR ASSUMED AS TO ABSOLUTE OR RELATIVE ACCURACY OR PRECISION OF ANY DATA CONTAINED HEREIN ARE MADE BY VEOLIA WATER PENNSYLVANIA, NOR WILL THE COMPANY BE HELD RESPONSIBLE FOR ANY USE OF THIS DOCUMENT FOR PURPOSES OTHER THAN WHICH IT IS INTENDED.

NO.	REVISION	DATE



VEOLIA WATER PENNSYLVANIA  
6310 ALLENTOWN BLVD  
HARRISBURG, PENNSYLVANIA 17112

DWG NAME			
DRAWN BY	SCALE	DATE	CAD FILE NAME
DRP	N.T.S.	11-27-17	SWPA-TYP DWG

TYPICAL THRUST BLOCK FOR VERTICAL BENDS

## NOTES :

All fittings shall be anchored by mechanical means or by concrete thrust blocks, or both, if required by the Boston Water and Sewer Commission or as noted on the contract plans.

All exposed metal shall be painted or coated. Concrete shall develop a minimum compressive stress of 3,000 p.s.i. at 28 days. Reinforcing steel shall be A.S.T.M. A615 Grade 40. Water pressure in Table 1 includes water hammer allowance.

The actual method of restraint must be determined by actual field conditions. These are typical installations to be used as a guide to the designer. Final designs are subject to review by the Boston Water and Sewer Commission.

## ILLUSTRATIVE PROBLEM

Design a thrust block for a 67-1/2° bend, a 24-inch diameter water main, carrying a maximum pressure of 200 p.s.i. Soil classified as a well graded compact coarse sand and gravel.

## SOLUTION

1. Enter Table I at 24-inch pipe diameter - go vertically down column until opposite 67-1/2° angle fitting. read thrust = 100.2 kips.
2. See chart immediately below Table I - select soil type curve reflecting actual soil classification. Type B for this problem.
3. Enter chart at thrust to be resisted and go vertically to soil type curve selected in 2 above - see chart and follow illustrative problem arrow line from 100.2 kip thrust to soil Type B curve.
4. From this intersection go horizontally following arrow line to intersection with required thrust block bearing area in square feet - 40 square feet minimum is required to resist thrust.
5. Continue horizontally to "thrust block dimensions" column and select dimensions "b" and "d" immediately above horizontal arrow line projection.  
7' - 0" square thrust block required for this problem.
6. Continue horizontally to "**reinforcing steel - each way**" column, noting columns further classification by soil type and footing type.  
(see "**thrust block detail**", for type I and type II requirements.)  
Two solutions to illustrative problem are acceptable:  
solution 1 - type I thrust block and soil type B indicate no reinforcement required.  
solution 2 - type II thrust block and soil type B indicate #5 A 12 each way required.

PIPE DIAMETER - INCHES	90° FITTING	OTHERS
6, 8, 10 & 12	1-6	1-0
16 & 20	2-0	1-6
24" - 30"	3-0	2-0

PIPE DIAMETER INCHES	6	8	10	12	16	20	24	30	36	42
DEAD ENDS AND TEES	5.6	10	15.8	22.6	40.2	62.8	90.4	141.0	203.6	277.0
ANGLE FITTINGS	90°	7.9	14.2	22.4	32.0	56.8	88.8	127.7	199.0	288.0
	87 1/2°	-	11.1	17.6	25.1	44.7	70.0	100.2	157.0	226.0
	56 1/4°	-	-	14.9	21.2	37.9	59.2	85.1	133.0	192.0
	45°	-	-	-	17.3	30.8	48.1	69.0	108.0	156.0
	33 3/4°	-	-	-	13.1	23.3	36.5	52.5	82.0	118.0
	22 1/2°	-	-	-	8.8	15.7	24.5	35.2	55.0	79.5
		-	-	-	-	-	-	-	-	-

DESIGN THRUST BLOCKS OR OTHER SUITABLE ANCHORAGE TO SUIT ACTUAL CONDITIONS

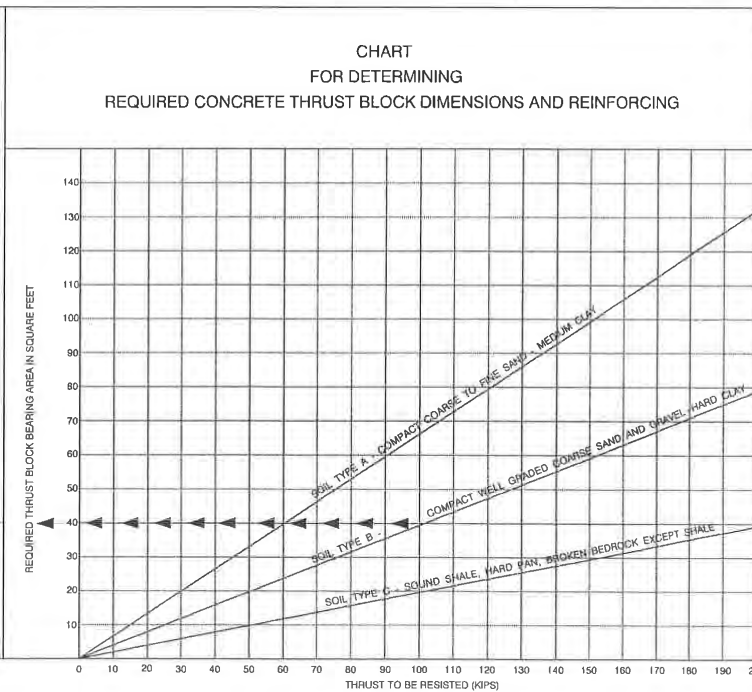
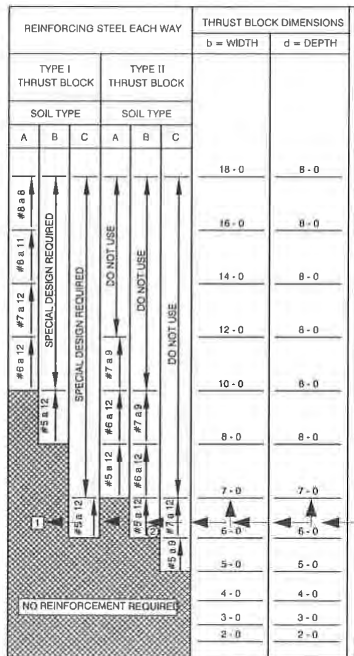

DO NOT PROJECT BEYOND CHART LIMITS SHOWN AS REINFORCEMENT WILL NOT BE ADEQUATE

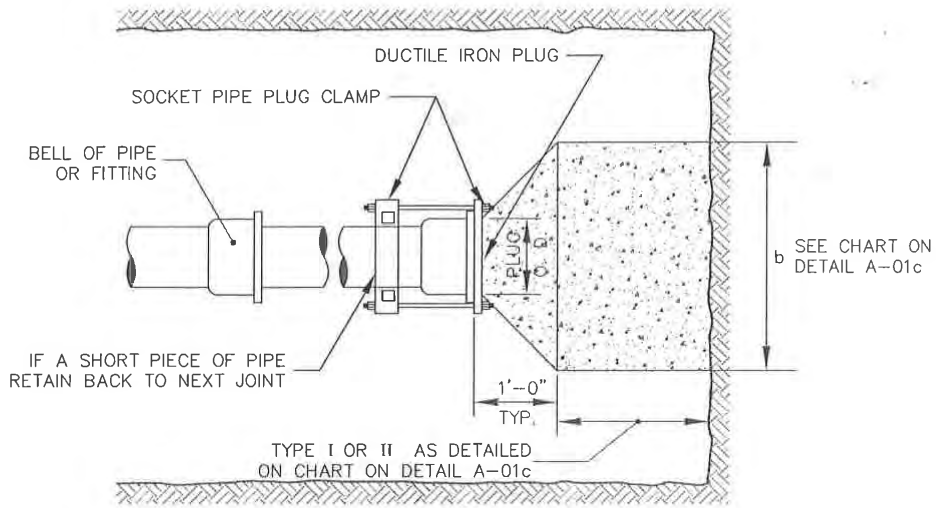

**PLAN - DEAD END**

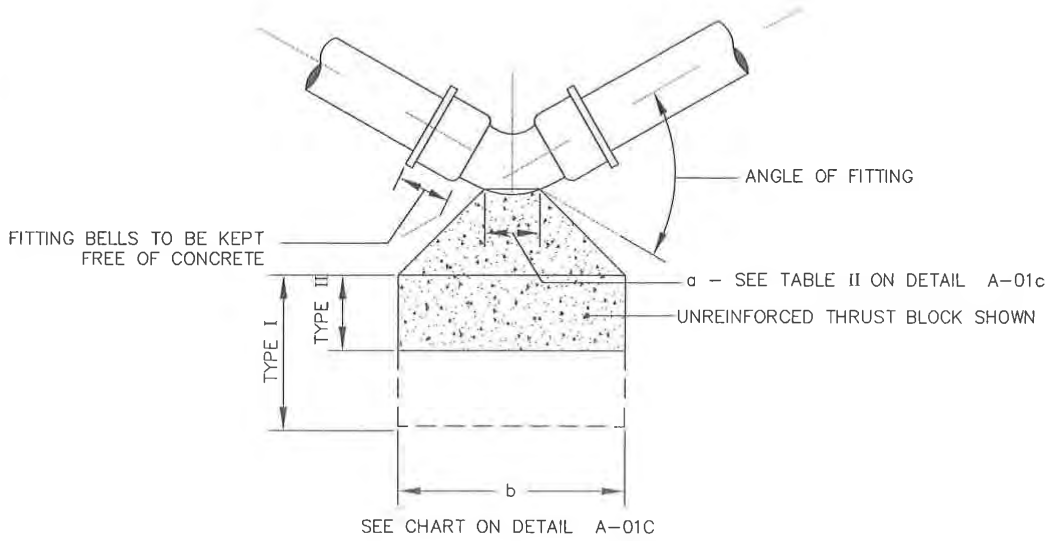

**PLAN - BEND**



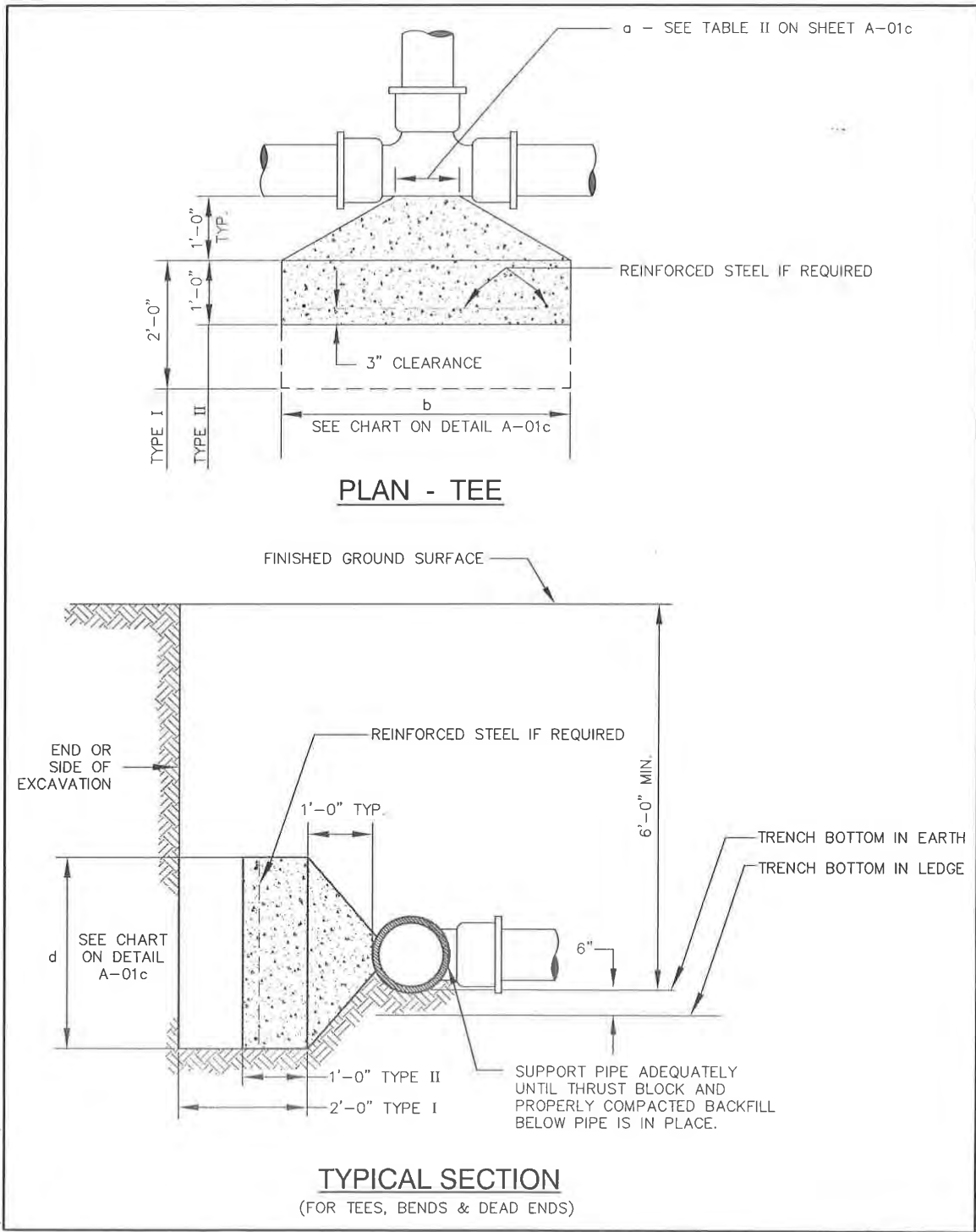

**NOTES;**

- 1) VALVE BOX SHALL NOT TRANSMIT SHOCK OR STRESS TO VALVE.
- 2) VALVE BOX SHALL BE CENTERED AND PLUMB OVER OPERATING NUT OF VALVE USING RUBBER VALVE BOX ADAPTER. VALVE SHALL BE FLUSH WITH THE FINAL SURFACE OF STREET OR GROUND AS DIRECTED BY THE ENGINEER.

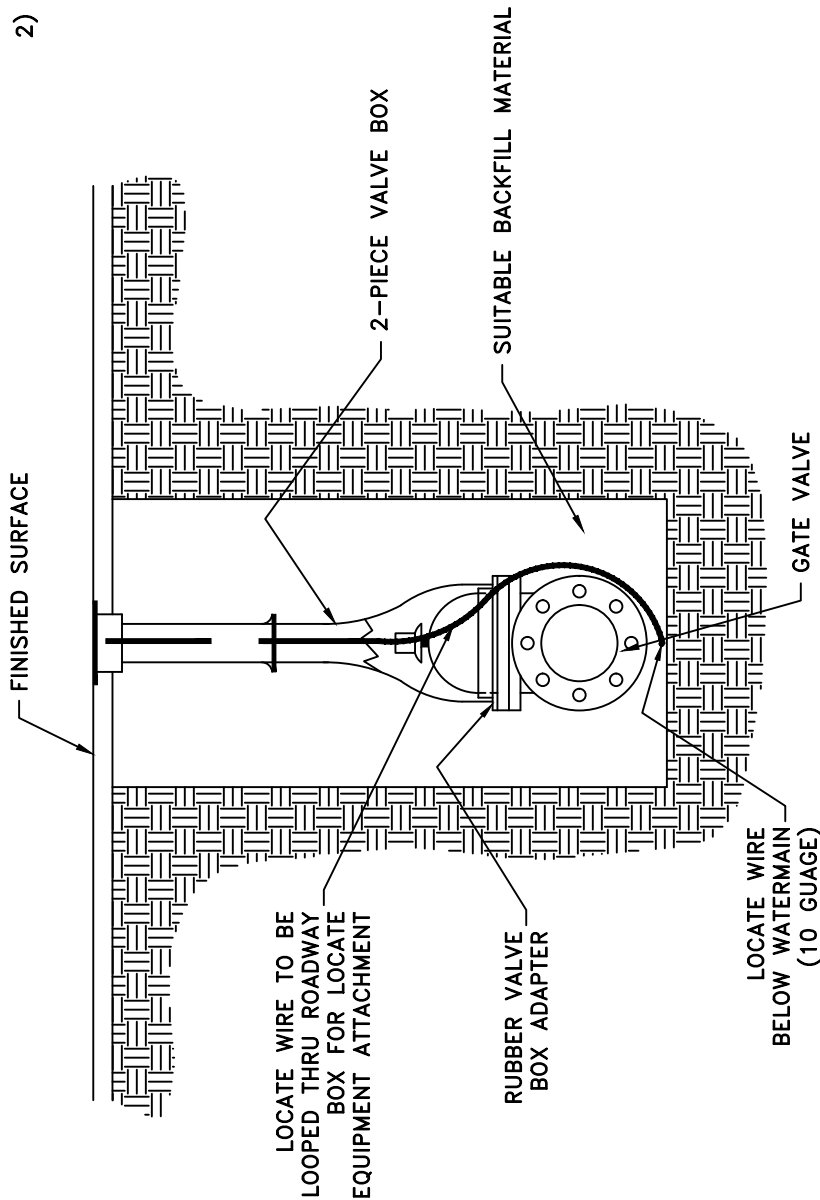

DWG NAME

TYPICAL VALVE BOX INSTALLATION

DRAWN BY

DRP

SCALE

N.T.S.

DATE

11-27-17

CAD FILE NAME

SWPA-TYP DWG



VEOLIA WATER PENNSYLVANIA  
6310 ALLENTOWN BLVD  
HARRISBURG, PENNSYLVANIA 17112

THIS DRAWING IS PROVIDED BY VEOLIA WATER PENNSYLVANIA FOR DISPLAY AND IS SUBJECT TO CHANGE WITHOUT NOTICE. NO CLAIMS, EITHER REAL OR ASSUMED AS TO ABSOLUTE OR RELATIVE ACCURACY OR PRECISION OF ANY DATA CONTAINED HEREIN ARE MADE BY VEOLIA WATER PENNSYLVANIA, NOR WILL THE COMPANY BE HELD RESPONSIBLE FOR ANY USE OF THIS DOCUMENT FOR PURPOSES OTHER THAN WHICH IT IS INTENDED.

NO.	REVISION	DATE

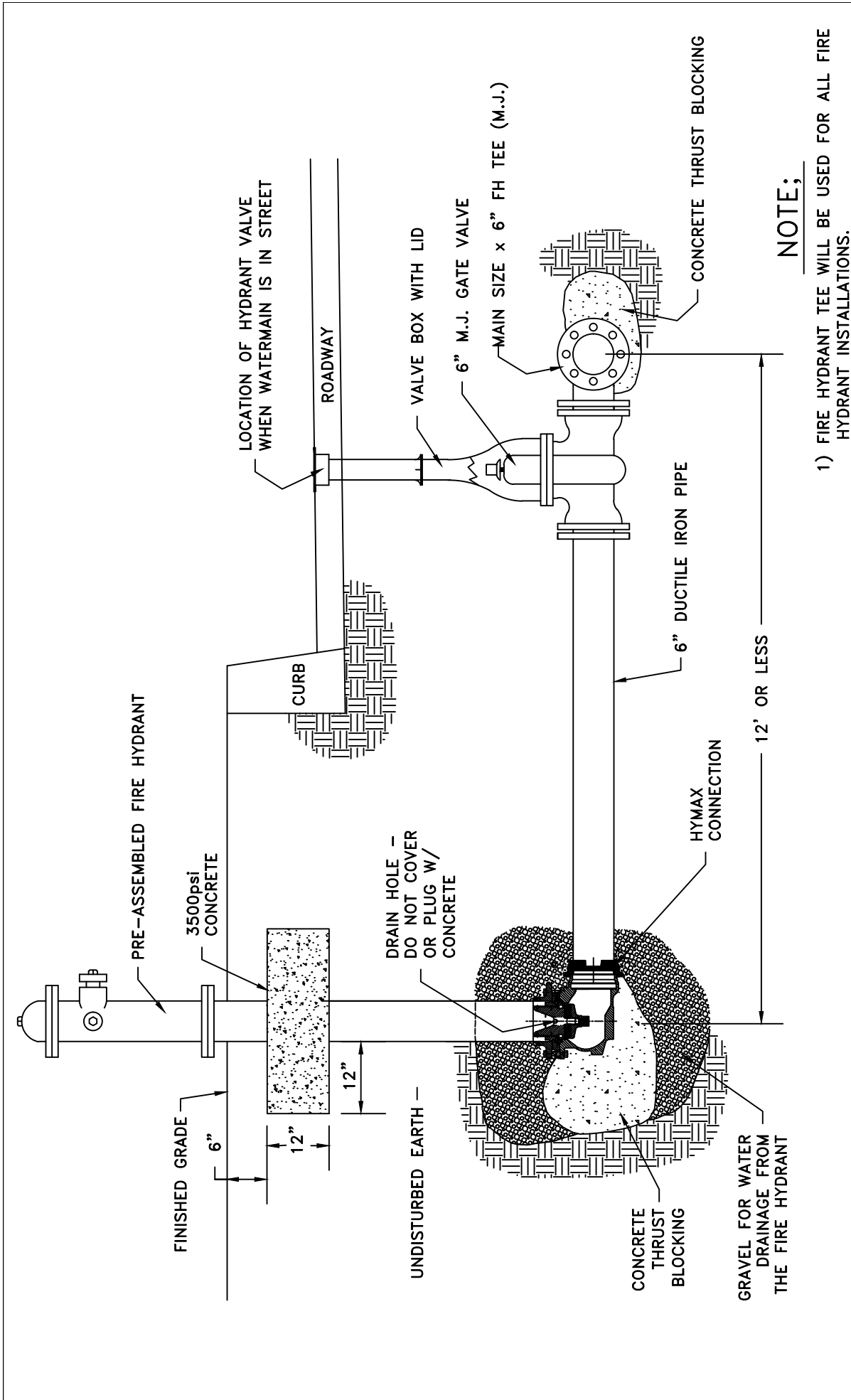

NOTE;  
 1) FIRE HYDRANT TEE WILL BE USED FOR ALL FIRE HYDRANT INSTALLATIONS.

THIS DRAWING IS PROVIDED BY VEOLIA WATER PENNSYLVANIA FOR DISPLAY AND IS SUBJECT TO CHANGE WITHOUT NOTICE. NO CLAIMS, EITHER REAL OR ASSUMED AS TO ABSOLUTE OR RELATIVE ACCURACY OR PRECISION OF ANY DATA CONTAINED HEREIN ARE MADE BY VEOLIA WATER PENNSYLVANIA, NOR WILL THE COMPANY BE HELD RESPONSIBLE FOR ANY USE OF THIS DOCUMENT FOR PURPOSES OTHER THAN WHICH IT IS INTENDED.		 VEOLIA WATER PENNSYLVANIA 6310 ALLENTOWN BLVD HARRISBURG, PENNSYLVANIA 17112		DWG NAME TYPICAL FIRE HYDRANT INSTALLATION USING HYMAX CONNECTION
NO.	REVISION	DATE	SCALE	DATE
1	HYMAX CONNECTION	2023	N.T.S.	11-21-22
			DRP	SWPA-TYP DWG

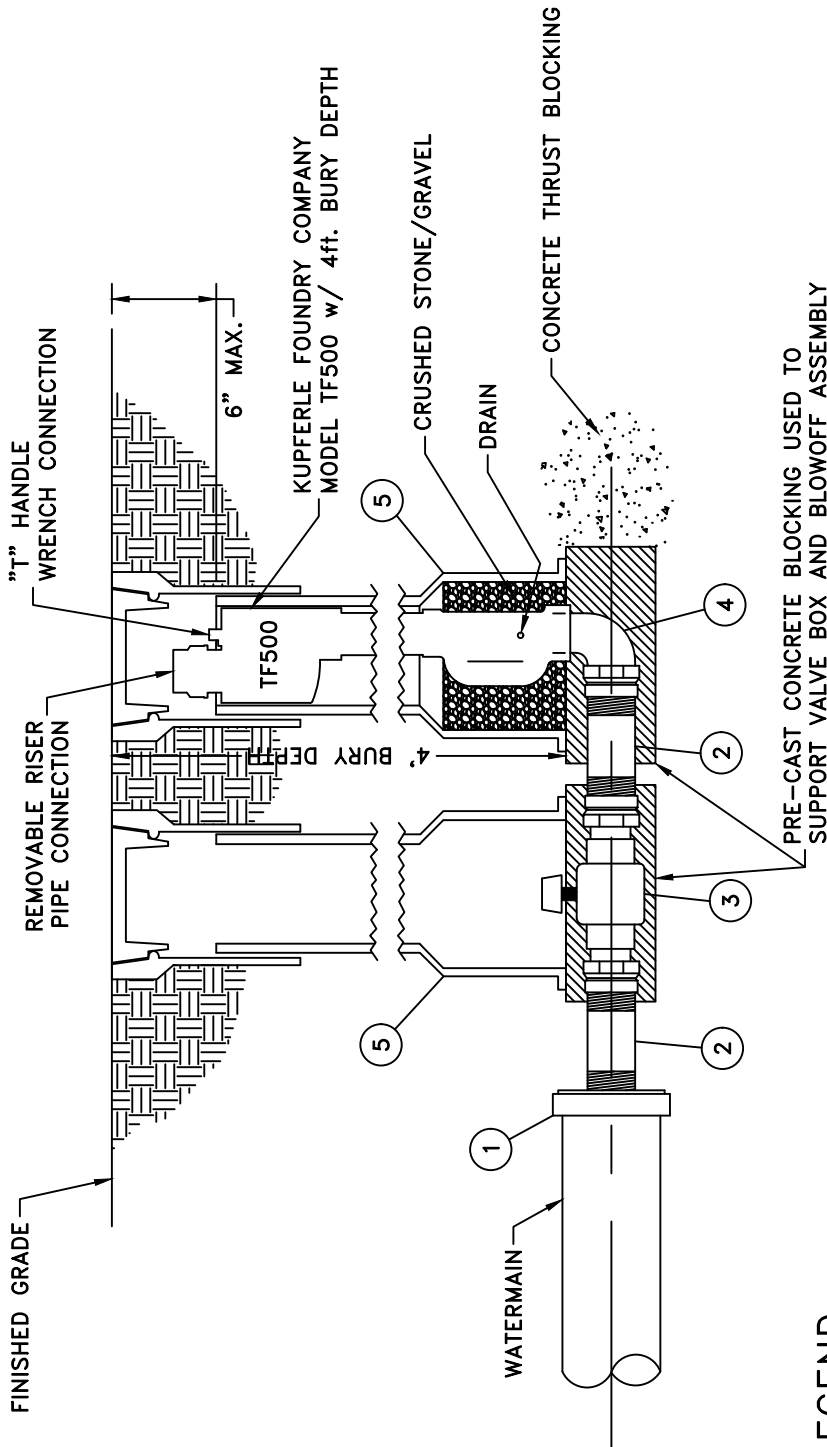

**LEGEND**

- 1) MAIN SIZE CAP W/ 2" IRON PIPE THREAD OUTLET
- 2) 2" GALVANIZED IRON PIPE
- 3) 2" F.I.P. THREADED CURB STOP - 1/4 TURN
- 4) 2" THREADED IRON PIPE ELBOW
- 5) 2 PIECE VALVE BOX W/ LID (SLIDE TYPE - 5.25" DIA.)

THIS DRAWING IS PROVIDED BY VEOLIA WATER PENNSYLVANIA FOR DISPLAY AND IS SUBJECT TO CHANGE WITHOUT NOTICE. NO CLAIMS, EITHER REAL OR ASSUMED AS TO ABSOLUTE OR RELATIVE ACCURACY OR PRECISION OF ANY DATA CONTAINED HEREIN ARE MADE BY VEOLIA WATER PENNSYLVANIA, NOR WILL THE COMPANY BE HELD RESPONSIBLE FOR ANY USE OF THIS DOCUMENT FOR PURPOSES OTHER THAN WHICH IT IS INTENDED.

NO.	REVISION	DATE



VEOLIA WATER PENNSYLVANIA  
6310 ALLENTOWN BLVD  
HARRISBURG, PENNSYLVANIA 17112

DWG NAME

TYPICAL 2" BLOWOFF ASSEMBLY  
FOR END OF WATERMAINS 4" & ABOVE

DRAWN BY

DRP

SCALE

N.T.S.

DATE

11-27-17

CAD FILE NAME

SWPA-TYP DWG

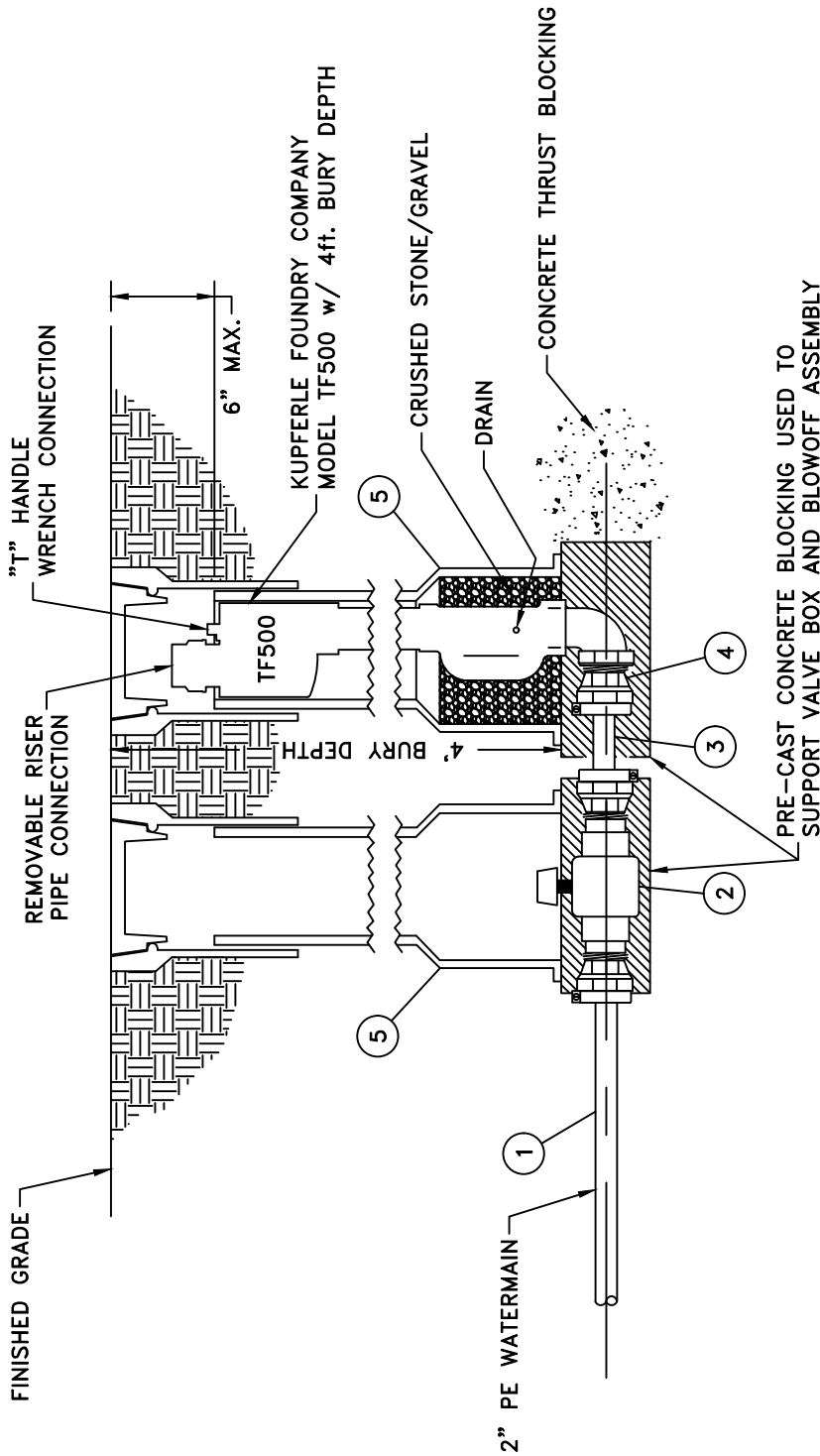

**LEGEND**

- 1) 2" PE WATERMAIN
- 2) 2" PE WATERMAIN
- 3) 2" PE WATERMAIN
- 4) 2" MIP COUPLING X PACK JOINT CTS COUPLER
- 5) 2" PE WATERMAIN

THIS DRAWING IS PROVIDED BY VEOLIA WATER PENNSYLVANIA FOR DISPLAY AND IS SUBJECT TO CHANGE WITHOUT NOTICE. NO CLAIMS, EITHER REAL OR ASSUMED AS TO ABSOLUTE OR RELATIVE ACCURACY OR PRECISION OF ANY DATA CONTAINED HEREIN ARE MADE BY VEOLIA WATER PENNSYLVANIA, NOR WILL THE COMPANY BE HELD RESPONSIBLE FOR ANY USE OF THIS DOCUMENT FOR PURPOSES OTHER THAN WHICH IT IS INTENDED.

NO.	REVISION	DATE



VEOLIA WATER PENNSYLVANIA  
6310 ALLENTOWN BLVD  
HARRISBURG, PENNSYLVANIA 17112

DWG NAME

TYPICAL 2" BLOWOFF ASSEMBLY  
FOR 2" WATERMANS

DRAWN BY

BBD

SCALE

N.T.S.

DATE

11-27-22

CAD FILE NAME

SWPA-TYP DWG

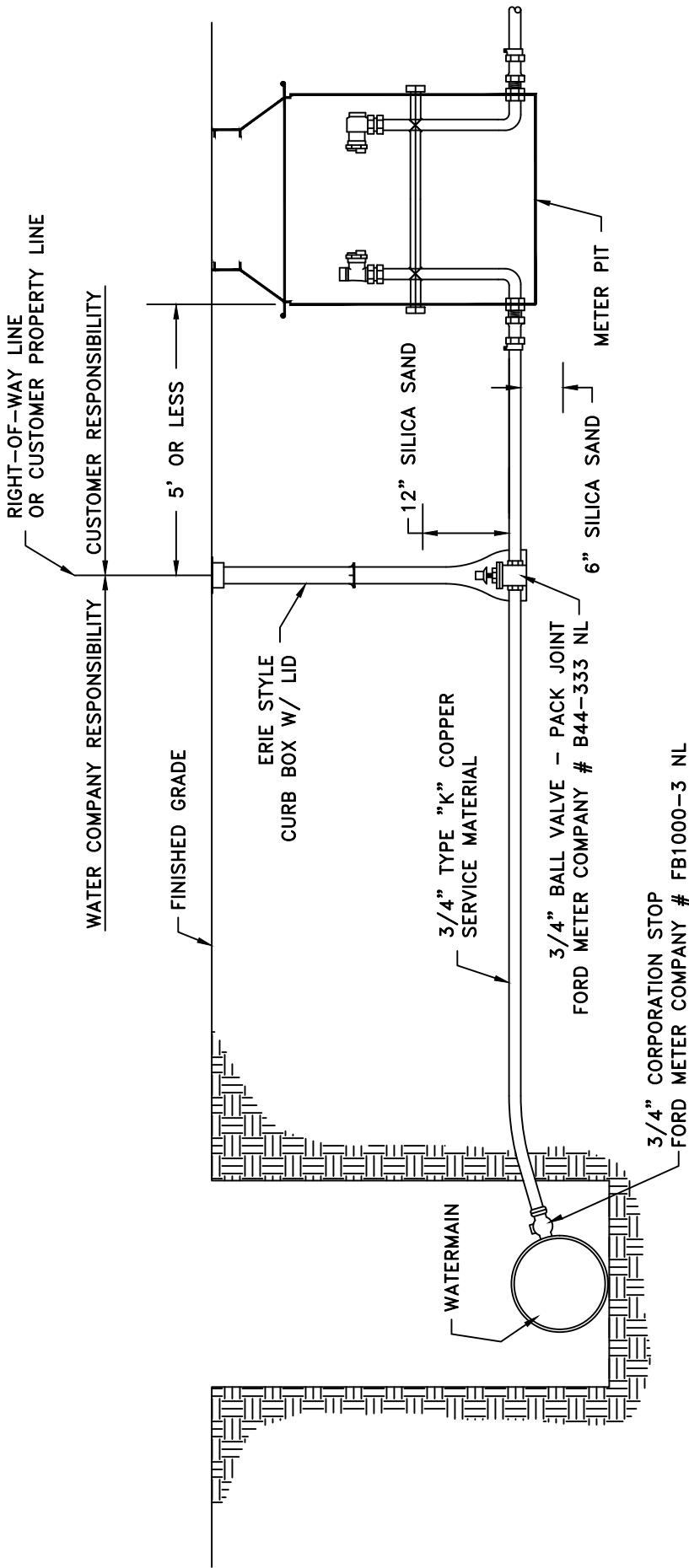

**NOTES:**

- 1) SILICA SAND BACKFILL FOR ALL COPPER AND BRASS
- 2) IF DIP MAIN IS LESS THAN 8" IN DIAMETER, A SERVICE SADDLE IS REQUIRED
- 3) A SERVICE SADDLE IS REQUIRED FOR ALL PVC AND PET WATERMAIN

THIS DRAWING IS PROVIDED BY VEOLIA WATER PENNSYLVANIA FOR DISPLAY AND IS SUBJECT TO CHANGE WITHOUT NOTICE. NO CLAIMS, EITHER REAL OR ASSUMED AS TO ABSOLUTE OR RELATIVE ACCURACY OR PRECISION OF ANY DATA CONTAINED HEREIN ARE MADE BY VEOLIA WATER PENNSYLVANIA, NOR WILL THE COMPANY BE HELD RESPONSIBLE FOR ANY USE OF THIS DOCUMENT FOR PURPOSES OTHER THAN WHICH IT IS INTENDED.

NO.	REVISION	DATE



VEOLIA WATER PENNSYLVANIA  
6310 ALLENTOWN BLVD  
HARRISBURG, PENNSYLVANIA 17112

DWG NAME

TYPICAL 3/4" SERVICE INSTALLATION

DRAWN BY

DRP

SCALE

N.T.S.

DATE

11-27-17

CAD FILE NAME

SWPA-TYP DWG

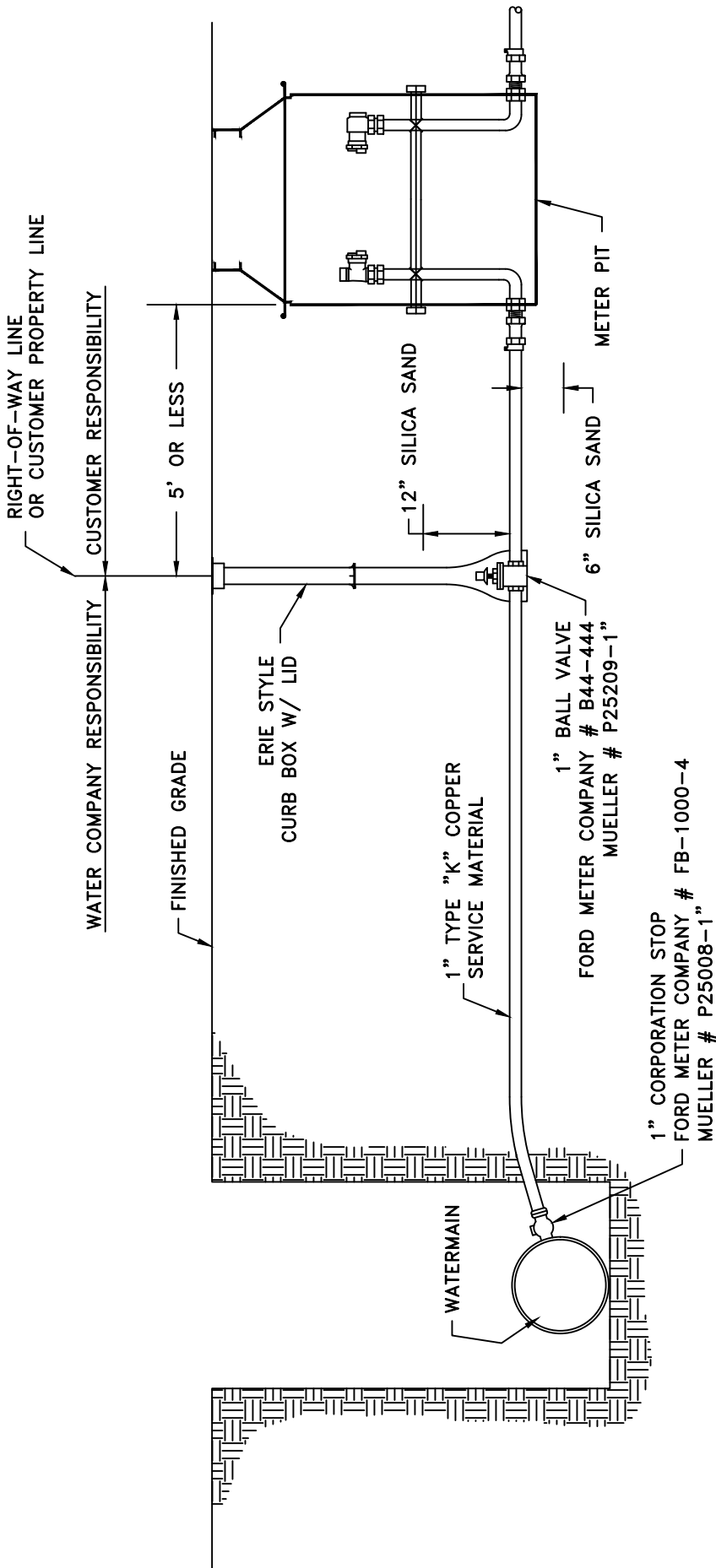

**NOTES:**

- 1) SILICA SAND BACKFILL FOR ALL COPPER AND BRASS
- 2) IF DIP MAIN IS LESS THAN 8" IN DIAMETER, A SERVICE SADDLE IS REQUIRED
- 3) A SERVICE SADDLE IS REQUIRED FOR ALL PVC AND PET WATERMAIN

THIS DRAWING IS PROVIDED BY VEOLIA WATER PENNSYLVANIA FOR DISPLAY AND IS SUBJECT TO CHANGE WITHOUT NOTICE. NO CLAIMS, EITHER REAL OR ASSUMED AS TO ABSOLUTE OR RELATIVE ACCURACY OR PRECISION OF ANY DATA CONTAINED HEREIN ARE MADE BY VEOLIA WATER PENNSYLVANIA, NOR WILL THE COMPANY BE HELD RESPONSIBLE FOR ANY USE OF THIS DOCUMENT FOR PURPOSES OTHER THAN WHICH IT IS INTENDED.

NO.	REVISION	DATE



VEOLIA WATER PENNSYLVANIA  
6310 ALLENTOWN BLVD  
HARRISBURG, PENNSYLVANIA 17112

DWG NAME

TYPICAL 1" SERVICE INSTALLATION  
FOR 8" AND LARGER WATERMAIN

DRAWN BY

DRP

SCALE

N.T.S.

DATE

11-27-17

CAD FILE NAME

SWPA-TYP DWG

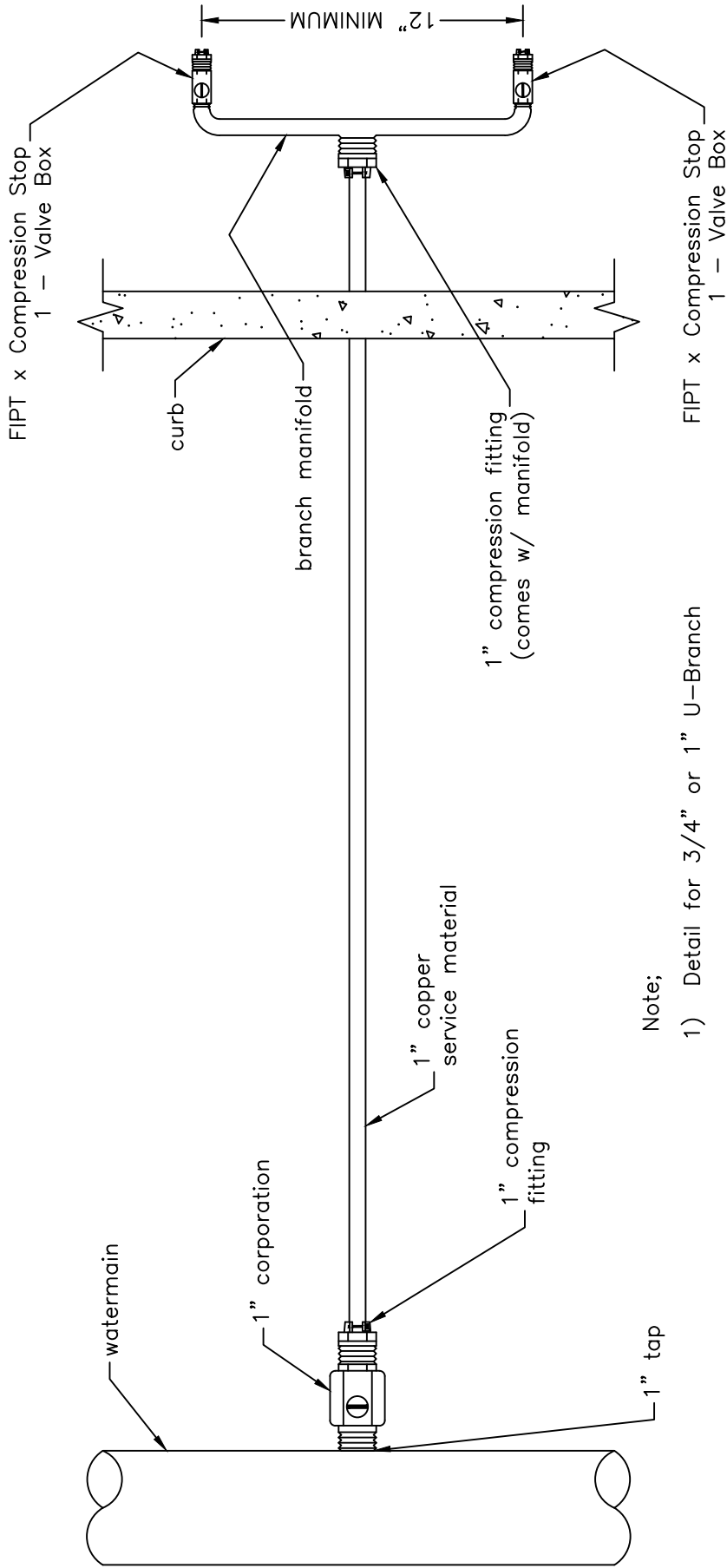

**Note:**

- 1) Detail for 3/4" or 1" U-Branch
- 2) Compression stop is threaded onto the 1" branch manifold.
- 3) Must use tapping saddle when attaching services to PVC pipe. or any main <8" diameter

DWG NAME

**LONG SIDE SERVICE  
NON-FIRE SERVICE - 3/4" / FIRE SERVICE - 1"**

DRAWN BY

DRP

SCALE

N.T.S.

DATE

11-27-17

CAD FILE NAME

SWPA-TYP DWG



**VEOLIA WATER PENNSYLVANIA**  
6310 ALLENTOWN BLVD  
HARRISBURG, PENNSYLVANIA 17112

THIS DRAWING IS PROVIDED BY VEOLIA WATER PENNSYLVANIA FOR DISPLAY AND IS SUBJECT TO CHANGE WITHOUT NOTICE. NO CLAIMS, EITHER REAL OR ASSUMED AS TO ABSOLUTE OR RELATIVE ACCURACY OR PRECISION OF ANY DATA CONTAINED HEREIN ARE MADE BY VEOLIA WATER PENNSYLVANIA, NOR WILL THE COMPANY BE HELD RESPONSIBLE FOR ANY USE OF THIS DOCUMENT FOR PURPOSES OTHER THAN WHICH IT IS INTENDED.

NO.	REVISION	DATE
	<b>REVISED FOR 2020</b>	



**NOTE: METER PIT MAY NOT BE INSTALLED IN VEHICLE TRAFFIC AREAS**

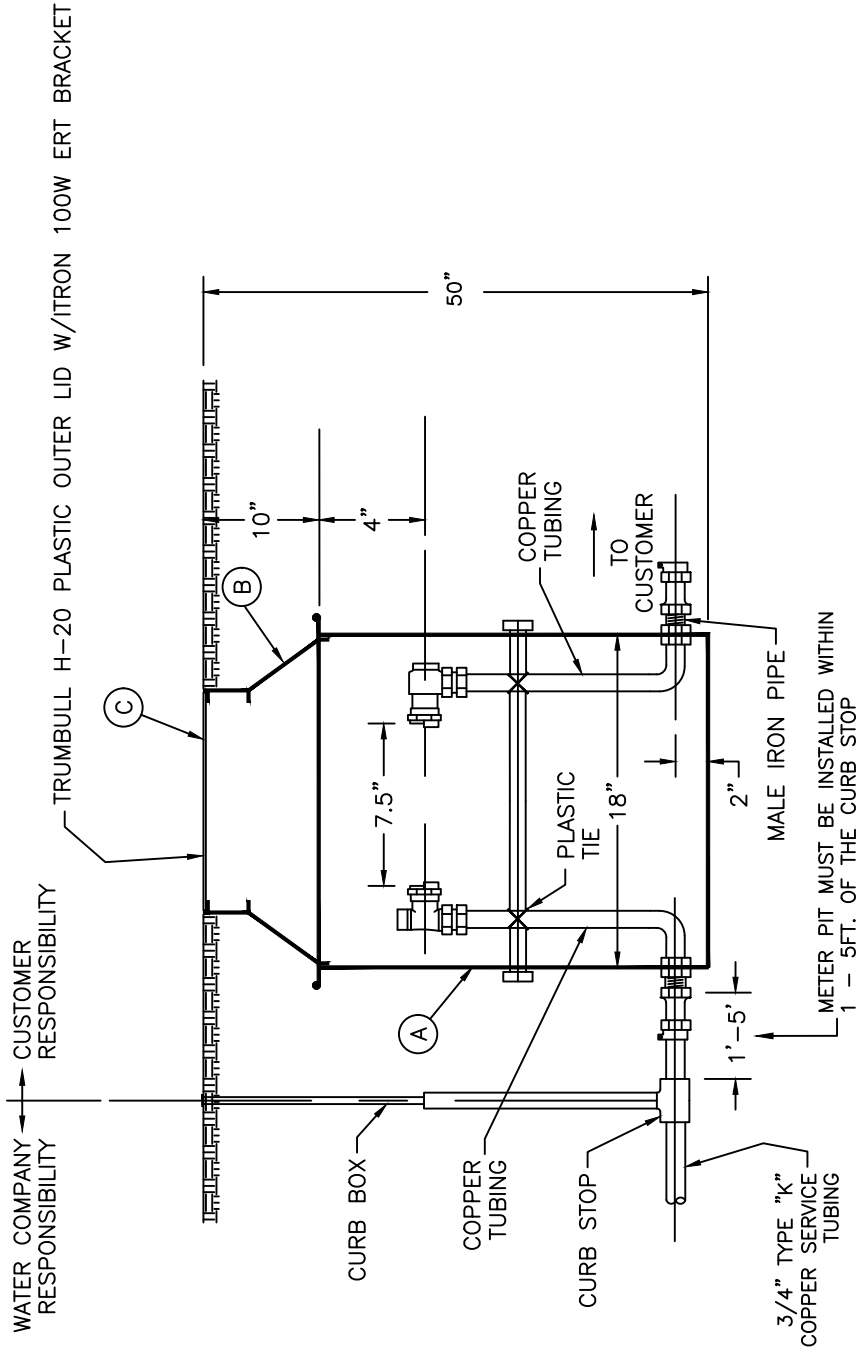

NOTE: SILICA SAND BACKFILL FOR ALL COPPER AND BRASS

THIS DRAWING IS PROVIDED BY VEOLIA WATER PENNSYLVANIA FOR DISPLAY AND IS SUBJECT TO CHANGE WITHOUT NOTICE. NO CLAIMS, EITHER REAL OR ASSUMED AS TO ABSOLUTE OR RELATIVE ACCURACY OR PRECISION OF ANY DATA CONTAINED HEREIN ARE MADE BY VEOLIA WATER PENNSYLVANIA, NOR WILL THE COMPANY BE HELD RESPONSIBLE FOR ANY USE OF THIS DOCUMENT FOR PURPOSES OTHER THAN WHICH IT IS INTENDED.

NO.	REVISION	DATE



VEOLIA WATER PENNSYLVANIA  
6310 ALLENTOWN BLVD  
HARRISBURG, PENNSYLVANIA 17112

DWG NAME

TYPICAL 5/8" x 3/4"  
METER PIT SETTER INSTALLATION

ITEM	DESCRIPTION
A	AY McDONALD 780W248WDPP 33X18X970 NO LEAD
B	AY McDONALD 74MWF18 FRAME ONLY - 1PE - 18PIT
C	TRUMBULL H-20 LID 367-5518 W/ ITRON 100W ERT BRACKET

DRAWN BY

SCALE

DATE

11-27-17

CAD FILE NAME

SWPA-TYP DWG

N.T.S.

DRP

**NEW FOR 2024**

**NOTE: METER PIT MAY NOT BE INSTALLED IN VEHICLE TRAFFIC AREAS**

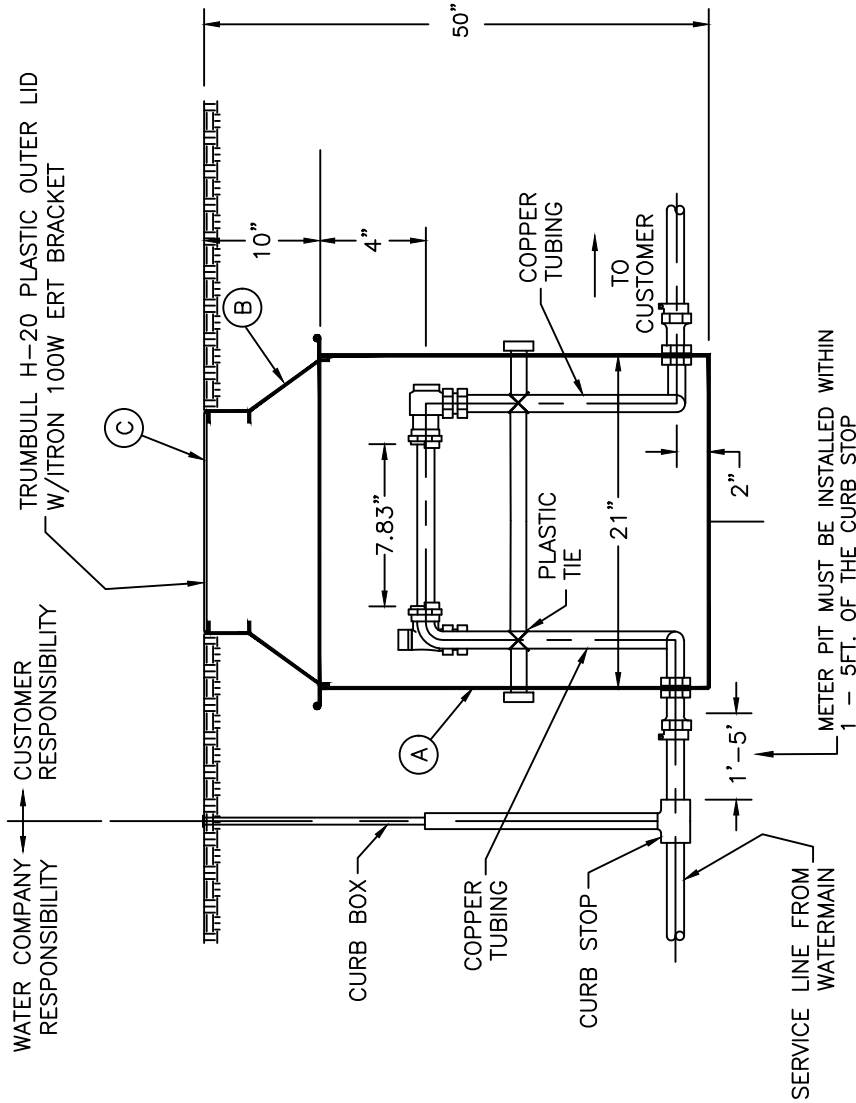

**NOTE:** Tandem meter pit for 5/8x3/4 meter, angle ball valve, UFR volumetric angle dual check, 3/4" MNPT in/out, s-bar + adapters for PRV, 21" pit diameter

THIS DRAWING IS PROVIDED BY VEOLIA WATER PENNSYLVANIA FOR DISPLAY AND IS SUBJECT TO CHANGE WITHOUT NOTICE. NO CLAIMS, EITHER REAL OR ASSUMED AS TO ABSOLUTE OR RELATIVE ACCURACY OR PRECISION OF ANY DATA CONTAINED HEREIN ARE MADE BY VEOLIA WATER PENNSYLVANIA, NOR WILL THE COMPANY BE HELD RESPONSIBLE FOR ANY USE OF THIS DOCUMENT FOR PURPOSES OTHER THAN WHICH IT IS INTENDED.

NO.	REVISION	DATE



VEOLIA WATER PENNSYLVANIA  
6310 ALLENTOWN BLVD  
HARRISBURG, PENNSYLVANIA 17112

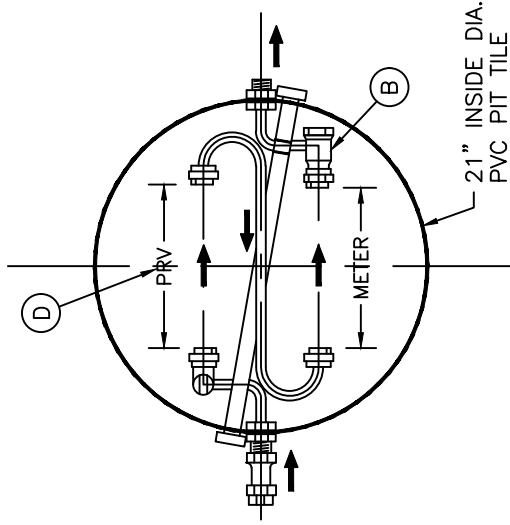

ITEM	DESCRIPTION
A	AY McDONALD 782W248QFPP 33X21X970 NO LEAD
B	AY McDONALD 74MWF21 FRAME ONLY - 1PGE - 21PIT
C	TRUMBULL H-20 Lid 367-5518 W/ ITRON 100W ERT BRACKET
D	WATTS N45BUM1 3/4" Pressure Reducing Valve

DWG NAME

5/8" X 3/4" METER  
3/4" PRV METER PIT

DRAWN BY	SCALE	DATE	CAD FILE NAME
	N.T.S.	04/28/23	

**NOTE: METER PIT MAY NOT BE INSTALLED IN VEHICLE TRAFFIC AREAS**

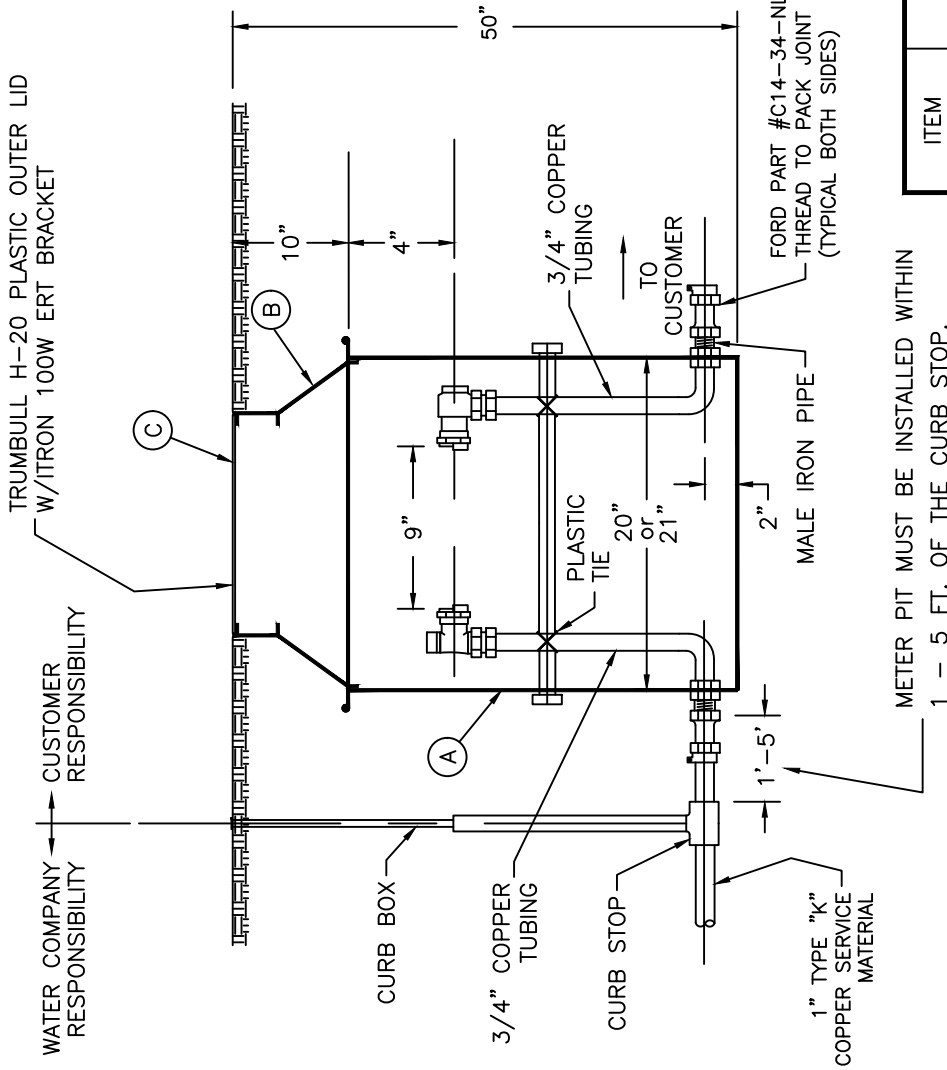

NOTE: SILICA SAND BACKFILL FOR ALL COPPER AND BRASS

THIS DRAWING IS PROVIDED BY VEOLIA WATER PENNSYLVANIA FOR DISPLAY AND IS SUBJECT TO CHANGE WITHOUT NOTICE. NO CLAIMS, EITHER REAL OR ASSUMED AS TO ABSOLUTE OR RELATIVE ACCURACY OR PRECISION OF ANY DATA CONTAINED HEREIN ARE MADE BY VEOLIA WATER PENNSYLVANIA, NOR WILL THE COMPANY BE HELD RESPONSIBLE FOR ANY USE OF THIS DOCUMENT FOR PURPOSES OTHER THAN WHICH IT IS INTENDED.

NO.	REVISION	DATE



DWG NAME	
TYPICAL 3/4" METER PIT SETTER INSTALLATION	
DRAWN BY	SCALE
DRP	N.T.S.
DATE	CAD FILE NAME
11-27-17	SWPA-TYP DWG

ITEM	DESCRIPTION
A	AY McDONALD 780W348WDP 33X21X970 NO LEAD
B	AY McDONALD 74MWF21 FRAME ONLY - 1PCE - 21 PIT
C	TRUMBULL H-20 LID 367-5518 W/ ITRON 100W ERT BRACKET

NOTE: METER PIT MAY NOT BE INSTALLED IN VEHICLE TRAFFIC AREAS

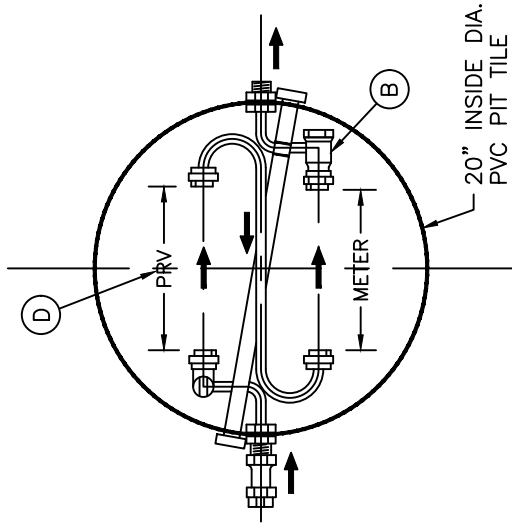
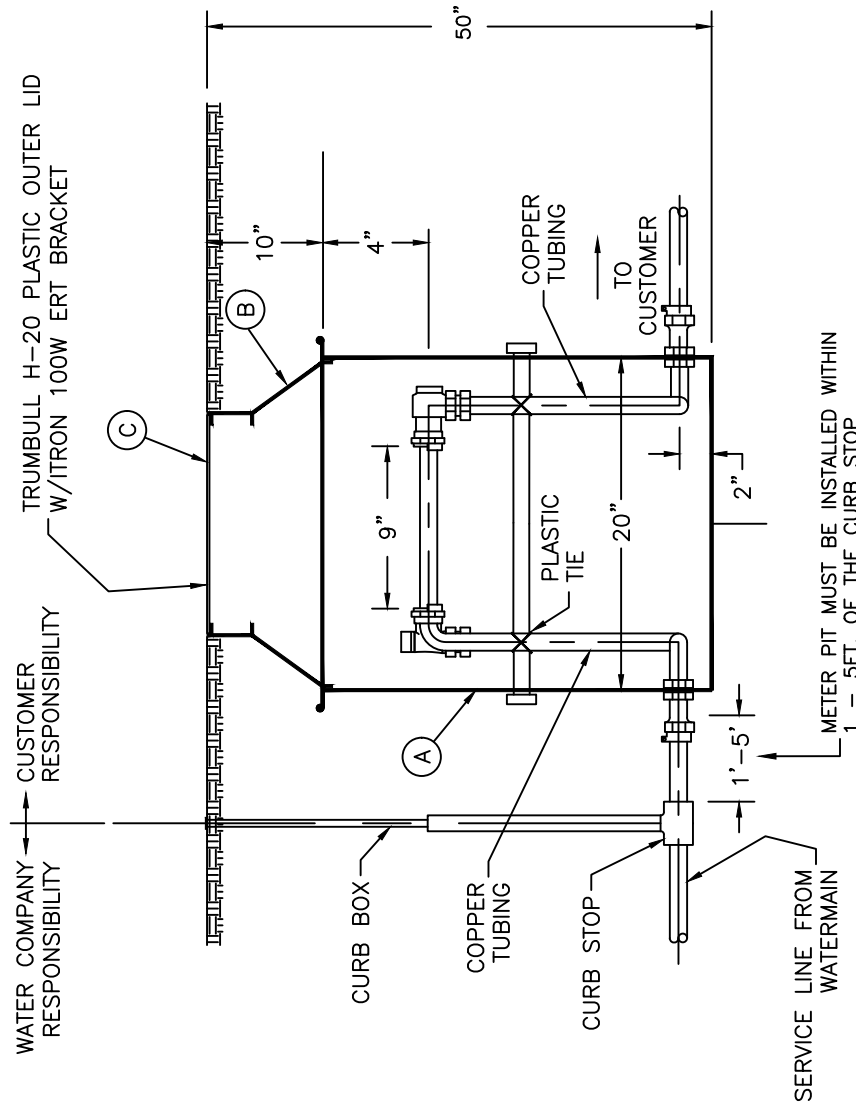

ITEM	DESCRIPTION - CUSTOMER SUPPLIED
A	AY McDONALD 780W248WPPP 33X18X970 NO LEAD
B	AY McDONALD 74MMFT18 FRAME ONLY - 1PE - 18PIT
C	TRUMBULL H-20 Lid 367-5518 W/ ITRON 100W ERT BRACKET
D	WATTS N45BUM1 3/4" Pressure Reducing Valve

DWG NAME		3/4" UFR PRV METER PIT	
DRAWN BY	SCALE	DATE	CAD FILE NAME
DRP	N.T.S.	11-27-17	SWPA-TYP DWG

VEOLIA WATER PENNSYLVANIA  
6310 ALLENTOWN BLVD  
HARRISBURG, PENNSYLVANIA 17112

THIS DRAWING IS PROVIDED BY VEOLIA WATER PENNSYLVANIA FOR DISPLAY AND IS SUBJECT TO CHANGE WITHOUT NOTICE. NO CLAIMS, EITHER REAL OR ASSUMED AS TO ABSOLUTE OR RELATIVE ACCURACY OR PRECISION OF ANY DATA CONTAINED HEREIN ARE MADE BY VEOLIA WATER PENNSYLVANIA, NOR WILL THE COMPANY BE HELD RESPONSIBLE FOR ANY USE OF THIS DOCUMENT FOR PURPOSES OTHER THAN WHICH IT IS INTENDED.

NO.	REVISION	DATE

NOTE: METER PIT MAY NOT BE INSTALLED IN VEHICLE TRAFFIC AREAS

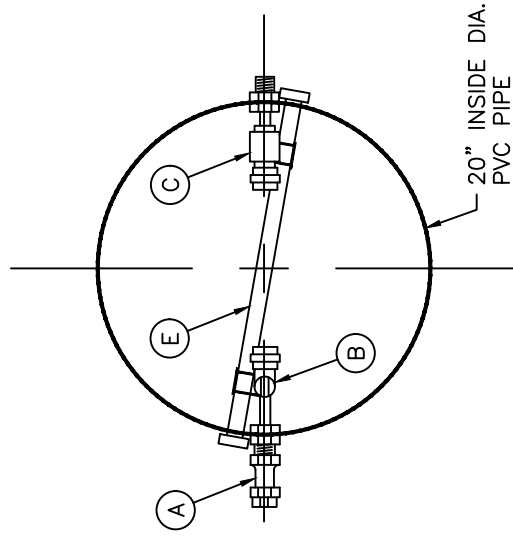
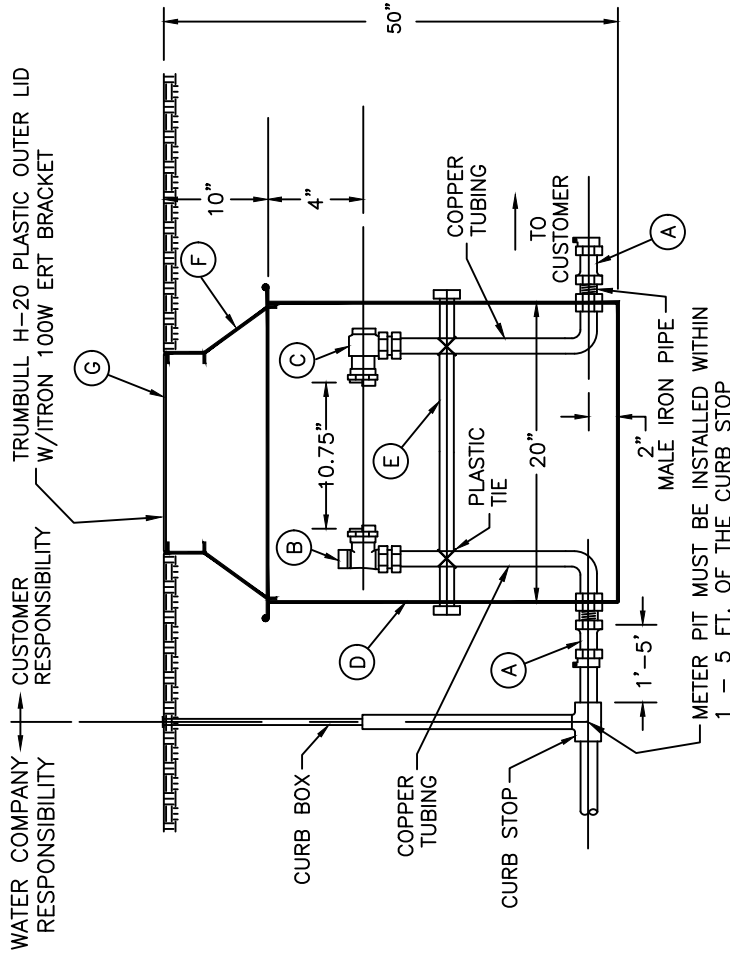

ITEM	DESCRIPTION
A	FIP by PJ (CTS)
B	ANGLE METER VALVE
C	ANGLE DUAL CHECK VALVE (backflow preventor)
D	20" PVC PIT SETTER
E	1/2" PVC SUPPORT & CAPS
F	WABASH FRAME
G	TRUMBULL H-20 LID 367-5518 W/ITRON 100W ERT BRACKET

NOTE:  
SILICA SAND BACKFILL FOR ALL COPPER AND BRASS

THIS DRAWING IS PROVIDED BY VEOLIA WATER PENNSYLVANIA FOR DISPLAY AND IS SUBJECT TO CHANGE WITHOUT NOTICE. NO CLAIMS, EITHER REAL OR ASSUMED AS TO ABSOLUTE OR RELATIVE ACCURACY OR PRECISION OF ANY DATA CONTAINED HEREIN ARE MADE BY VEOLIA WATER PENNSYLVANIA, NOR WILL THE COMPANY BE HELD RESPONSIBLE FOR ANY USE OF THIS DOCUMENT FOR PURPOSES OTHER THAN WHICH IT IS INTENDED.

NO.	REVISION	DATE



VEOLIA WATER PENNSYLVANIA  
6310 ALLENTOWN BLVD  
HARRISBURG, PENNSYLVANIA 17112

DWG NAME  
**TYPICAL 1" METER PIT SETTING**

DRAWN BY DRP	SCALE N.T.S.	DATE 11-27-17	CAD FILE NAME SWPA-TYP DWG
-----------------	-----------------	------------------	-------------------------------

Note; Meter setting must match meter size as specified by WPA. If reducers are required, they are the responsibility of the owner.

**NOTE: METER PIT MAY NOT BE INSTALLED IN VEHICLE TRAFFIC AREAS**

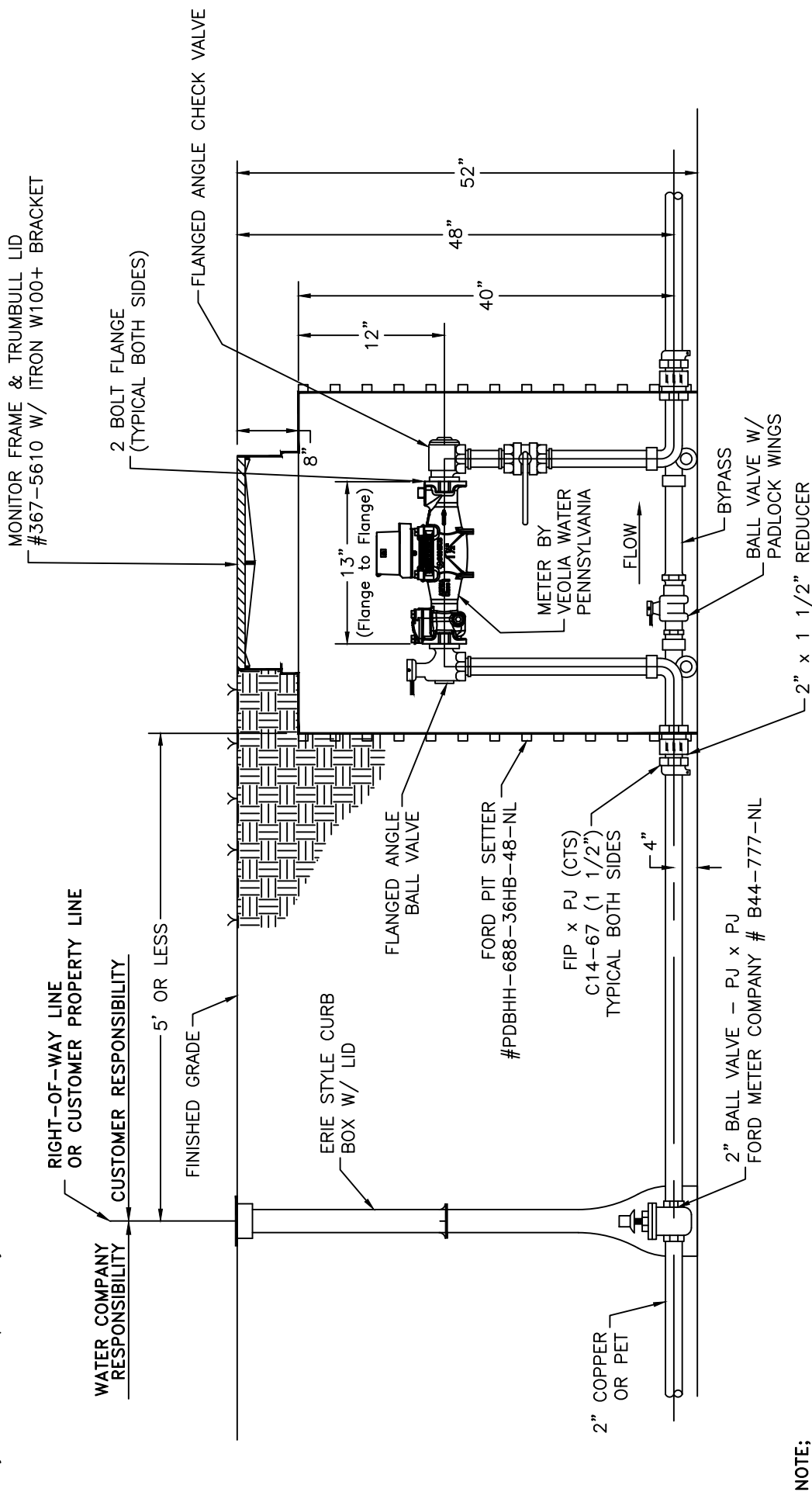

**NOTE:**

1) SILICA SAND BACKFILL FOR ALL COPPER AND BRASS

THIS DRAWING IS PROVIDED BY VEOLIA WATER PENNSYLVANIA FOR DISPLAY AND IS SUBJECT TO CHANGE WITHOUT NOTICE. NO CLAIMS, EITHER REAL OR ASSUMED AS TO ABSOLUTE OR RELATIVE ACCURACY OR PRECISION OF ANY DATA CONTAINED HEREIN ARE MADE BY VEOLIA WATER PENNSYLVANIA, NOR WILL THE COMPANY BE HELD RESPONSIBLE FOR ANY USE OF THIS DOCUMENT FOR PURPOSES OTHER THAN WHICH IT IS INTENDED.

NO.	REVISION	DATE



VEOLIA WATER PENNSYLVANIA  
6310 ALLENTOWN BLVD  
HARRISBURG, PENNSYLVANIA 17112

DWG NAME

TYPICAL 1 1/2"  
METER PIT SETTER INSTALLATION

DRAWN BY

DRP

SCALE

N.T.S.

DATE

11-27-17

CAD FILE NAME

SWPA-TYP DWG



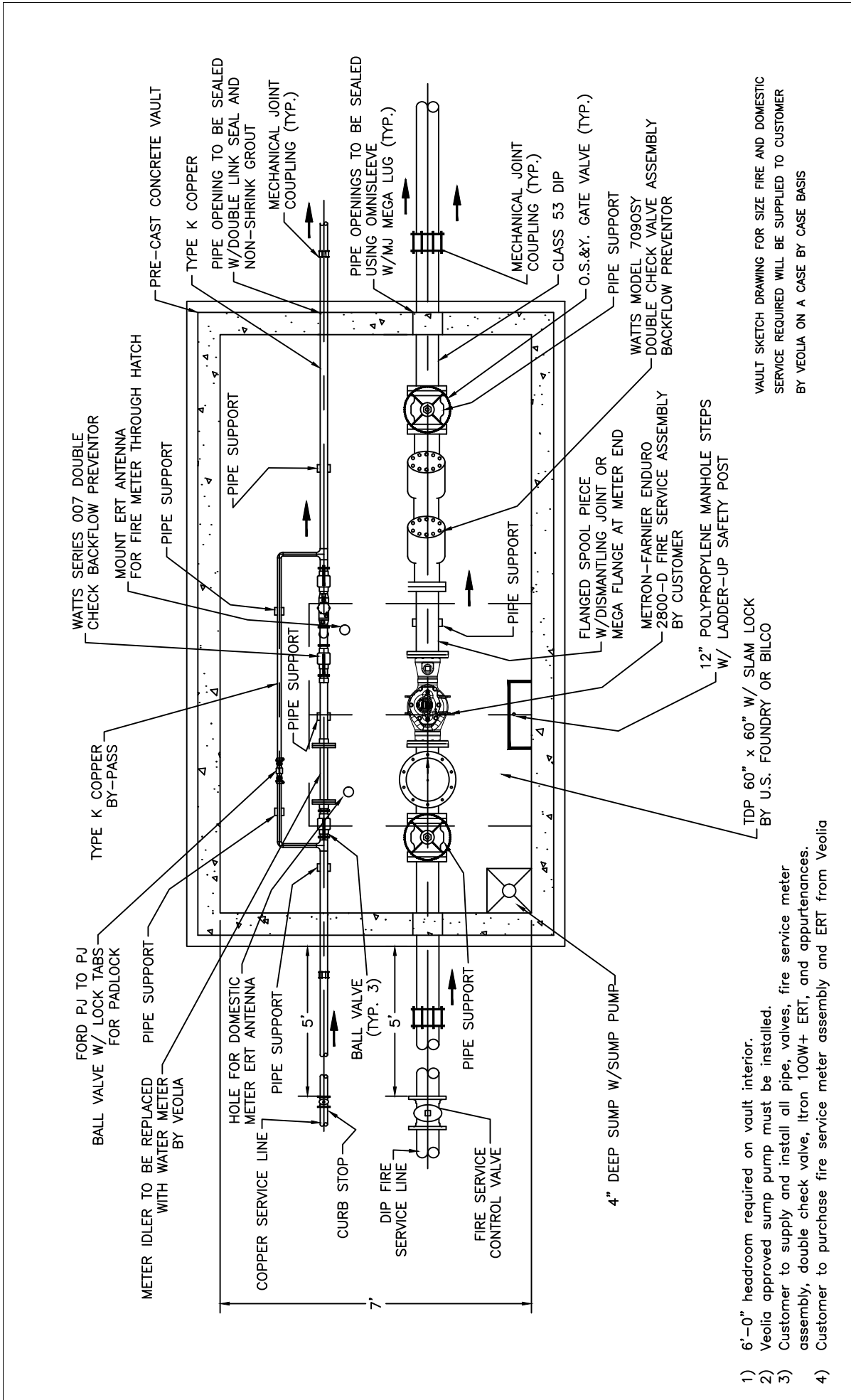

THIS DRAWING IS PROVIDED BY VEOLIA WATER PENNSYLVANIA FOR DISPLAY AND IS SUBJECT TO CHANGE WITHOUT NOTICE. NO CLAIMS, EITHER REAL OR ASSUMED AS TO ABSOLUTE OR RELATIVE ACCURACY OR PRECISION OF ANY DATA CONTAINED HEREIN ARE MADE BY VEOLIA WATER PENNSYLVANIA, NOR WILL THE COMPANY BE HELD RESPONSIBLE FOR ANY USE OF THIS DOCUMENT FOR PURPOSES OTHER THAN WHICH IT IS INTENDED.		DWG NAME <b>TYPICAL FS/DS METER VAULT</b> NOT FOR CONSTRUCTION - REFERENCE ONLY		
		DRAWN BY DRP	SCALE N.T.S.	DATE 11-27-17
NO.	REVISION	VEOLIA VEOLIA WATER PENNSYLVANIA 6310 ALLENTOWN BLVD HARRISBURG, PENNSYLVANIA 17112		
NO.	REVISION	DATE	TYPICAL FS/DS METER VAULT NOT FOR CONSTRUCTION - REFERENCE ONLY	



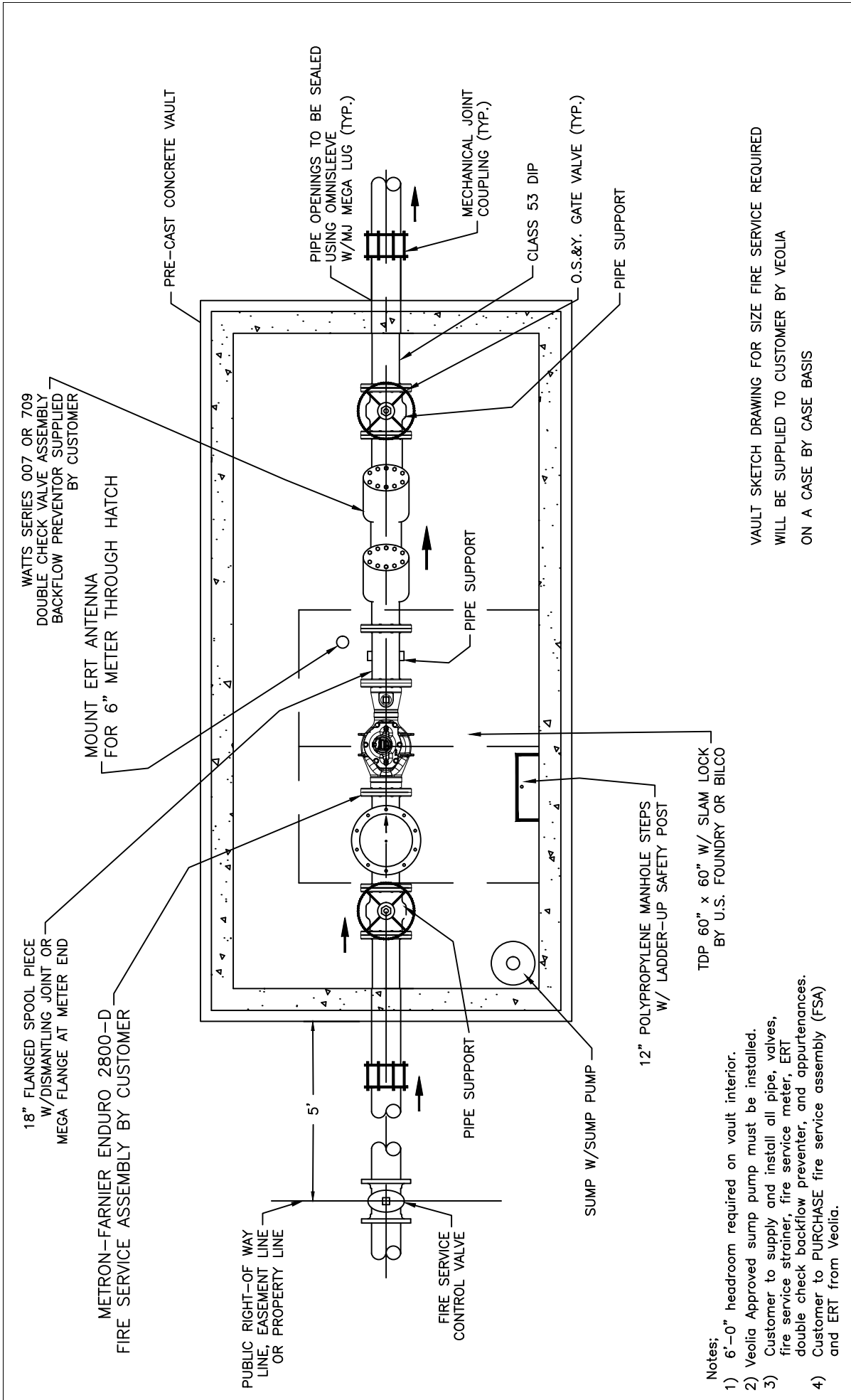

VAULT SKETCH DRAWING FOR SIZE FIRE SERVICE REQUIRED  
 WILL BE SUPPLIED TO CUSTOMER BY VEOLIA  
 ON A CASE BY CASE BASIS

- Notes:
- 1) 6'-0" headroom required on vault interior.
  - 2) Veolia Approved sump pump must be installed.
  - 3) Customer to supply and install all pipe, valves, fire service strainer, fire service meter, ERT double check backflow preventer, and appurtenances.
  - 4) Customer to PURCHASE fire service assembly (FSA) and ERT from Veolia.

 VEOLIA WATER PENNSYLVANIA 6310 ALLENTOWN BLVD HARRISBURG, PENNSYLVANIA 17112		DWG NAME	TYPICAL FIRE SERVICE VAULT - FOR REFERENCE ONLY DO NOT USE FOR DESIGN OR CONSTRUCTION	
		DRAWN BY	SCALE	DATE
NO.	REVISION	DATE		
			DRP	N.T.S.
			11-27-17	SWPA-TYP DWG

NOTE;  
IF DOMESTIC SERVICE SIZE IS 2" OR SMALLER, EXISTING STUB MUST  
BE TAPPED W/ TAPPING SADDLE FOR ALL PVC AND DIP <8" DIAMETER  
OR DIRECT THREADED INTO WATERMAIN (DIP) >/=8" DIAMETER

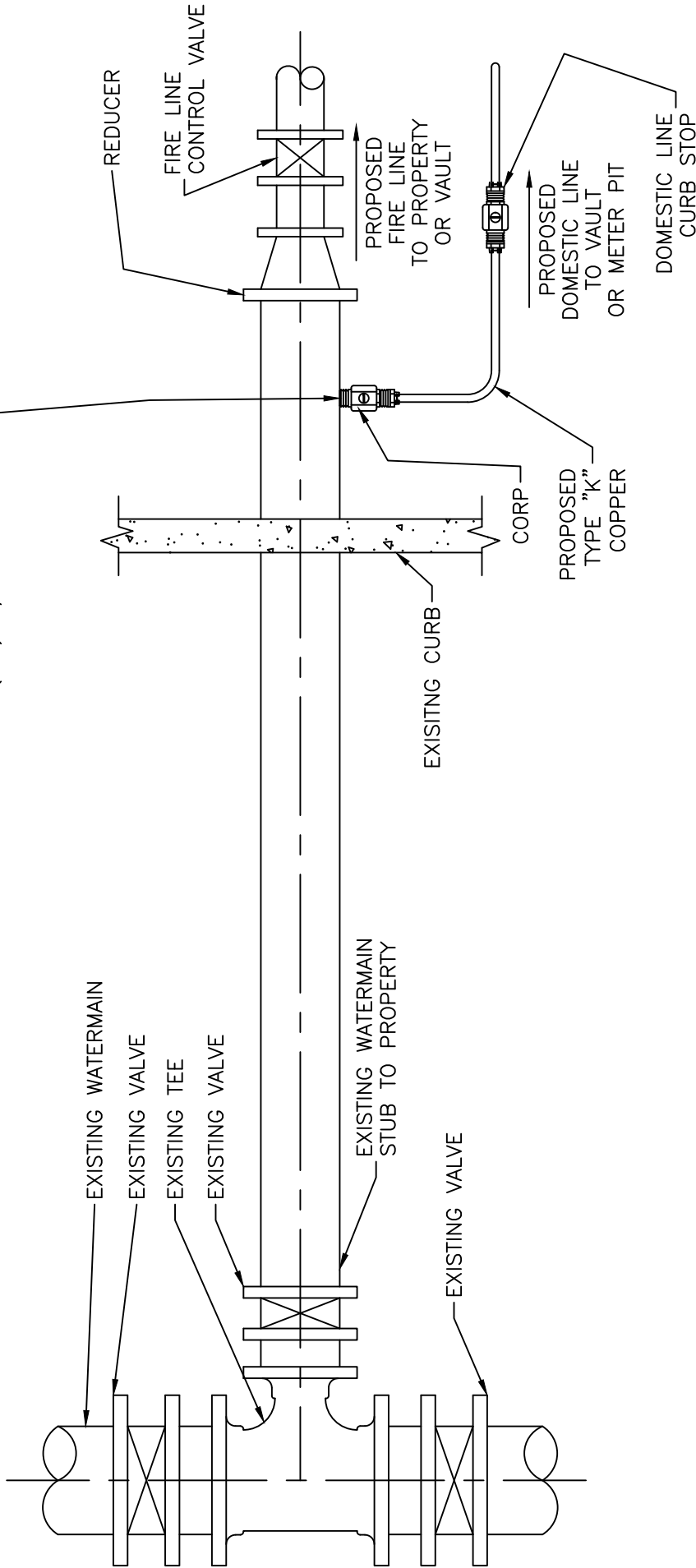

DWG NAME

PROPOSED DOMESTIC / FIRE FITTINGS  
ON EXISTING WATERMAIN STUB

DRAWN BY

DRP

SCALE

N.T.S.

DATE

11-27-17

CAD FILE NAME

SWPA-TYP DWG



VEOLIA WATER PENNSYLVANIA  
6310 ALLENTOWN BLVD  
HARRISBURG, PENNSYLVANIA 17112

THIS DRAWING IS PROVIDED BY VEOLIA WATER PENNSYLVANIA FOR DISPLAY AND IS SUBJECT TO CHANGE WITHOUT NOTICE. NO CLAIMS, EITHER REAL OR ASSUMED AS TO ABSOLUTE OR RELATIVE ACCURACY OR PRECISION OF ANY DATA CONTAINED HEREIN ARE MADE BY VEOLIA WATER PENNSYLVANIA, NOR WILL THE COMPANY BE HELD RESPONSIBLE FOR ANY USE OF THIS DOCUMENT FOR PURPOSES OTHER THAN WHICH IT IS INTENDED.

NO.	REVISION	DATE

**REVISED FOR 2020**

NOTE: METER PIT MAY NOT BE INSTALLED IN VEHICLE TRAFFIC AREAS

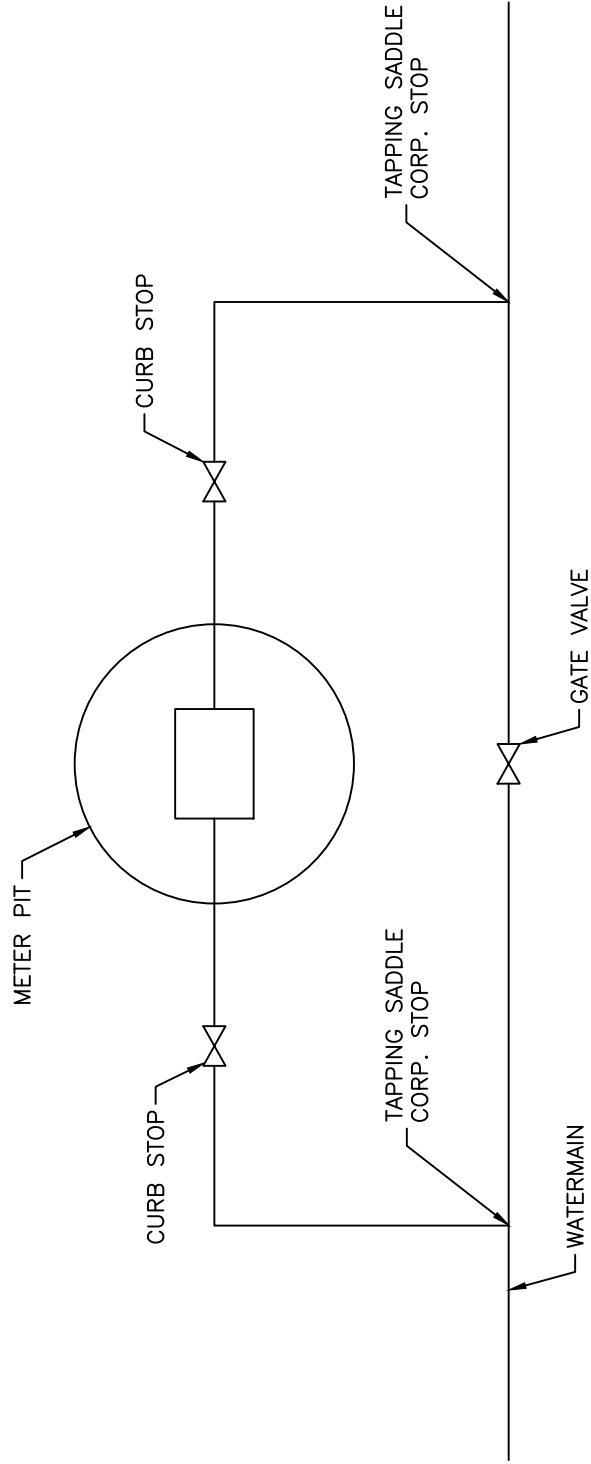

DWG NAME

TYPICAL LEAK DETECTION  
METER PIT INSTALLATION

DRAWN BY

DRP

SCALE

N.T.S.

DATE

11-27-17

CAD FILE NAME

SWPA-TYP DWG



VEOLIA WATER PENNSYLVANIA  
6310 ALLENTOWN BLVD  
HARRISBURG, PENNSYLVANIA 17112

THIS DRAWING IS PROVIDED BY VEOLIA WATER PENNSYLVANIA FOR DISPLAY AND IS SUBJECT TO CHANGE WITHOUT NOTICE. NO CLAIMS, EITHER REAL OR ASSUMED AS TO ABSOLUTE OR RELATIVE ACCURACY OR PRECISION OF ANY DATA CONTAINED HEREIN ARE MADE BY VEOLIA WATER PENNSYLVANIA, NOR WILL THE COMPANY BE HELD RESPONSIBLE FOR ANY USE OF THIS DOCUMENT FOR PURPOSES OTHER THAN WHICH IT IS INTENDED.

NO.	REVISION	DATE

ECLIPSE NO. 88  
Sampling Station



NO. 88  
Eclipse  
Standard



NO. 88-2  
California



NO. 88-1  
California

## ECLIPSE #88 SAMPLING STATION

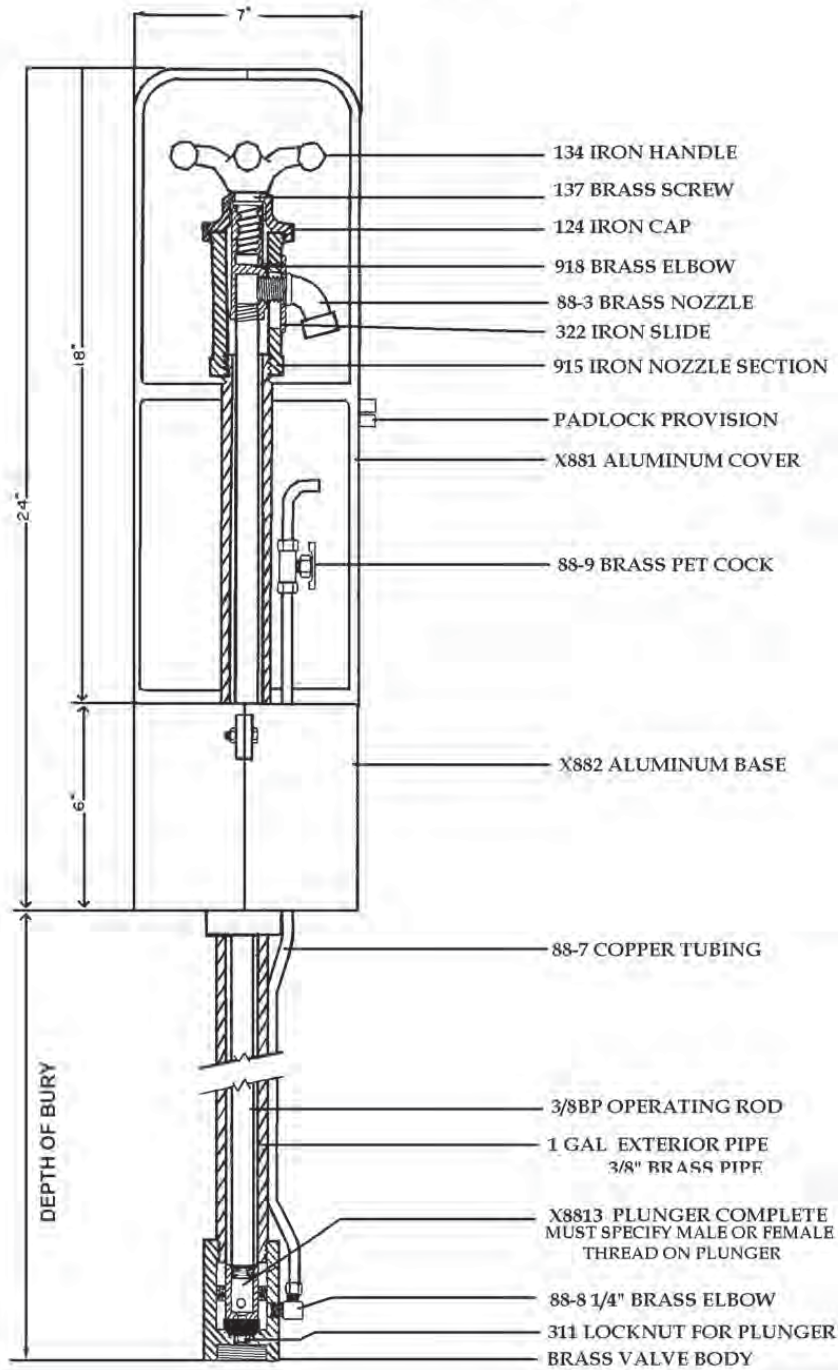

**KUPFERLE FOUNDRY COMPANY**

2511 N. 9TH STREET, ST. LOUIS, MO 63102  
(314) 231-8738 FAX (314) 231-2820 (800) 231-3990



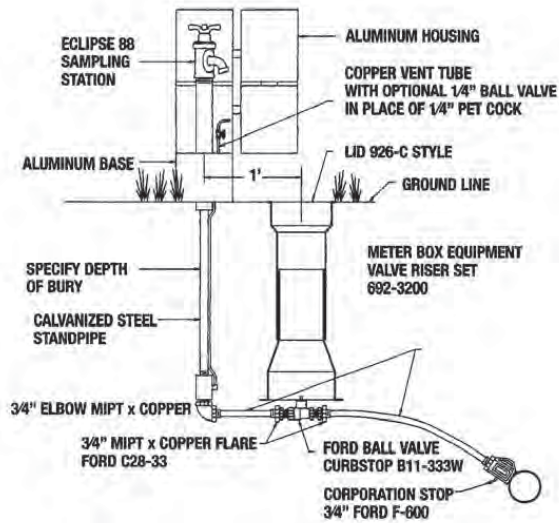

### #88 Specifications

Sampling Stations shall be \_\_\_' bury, with a 3/4" FIP inlet, and (3/4" hose or unthreaded) nozzle. All stations shall be enclosed in a lockable, nonremovable, aluminum-cast housing.

When opened, the station shall require no key for operation, and the water will flow in an all brass waterway.

All working parts will also be of brass and be removable from above ground with no digging. Exterior piping shall be galvanized steel (brass pipe also available).

A copper vent tube will enable each station to be pumped free of standing water to prevent freezing and to minimize bacteria growth.

Eclipse No. 88 Sampling Station shall be manufactured by Kupferle Foundry, St. Louis, MO 63102.

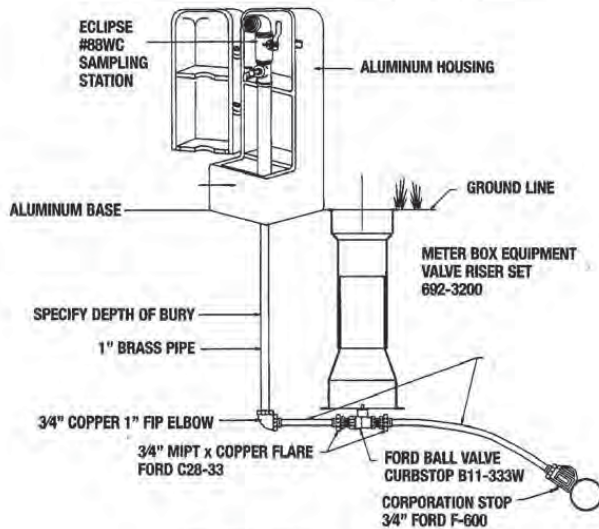

### #88WC Specifications

Sampling Stations shall be \_\_\_' bury, with a 1" MIP inlet, and a 1" FIP discharge. A 1/4" bent-nose sampling bibb shall be located before the discharge.

All stations shall be enclosed in a lockable, nonremovable, aluminum-cast housing.

When opened, the station shall require no key for operation, and the water will flow in an all brass waterway.

All working parts will also be of brass and be removable from above ground with no digging. (OPTIONAL: if desired, a 1/2" brass drain tube will be provided within the locking cover).

A 1" ball valve will control the water flow, and be located before (or after) the sampling bibb, as manufactured by Kupferle Foundry, St. Louis, MO 63102.

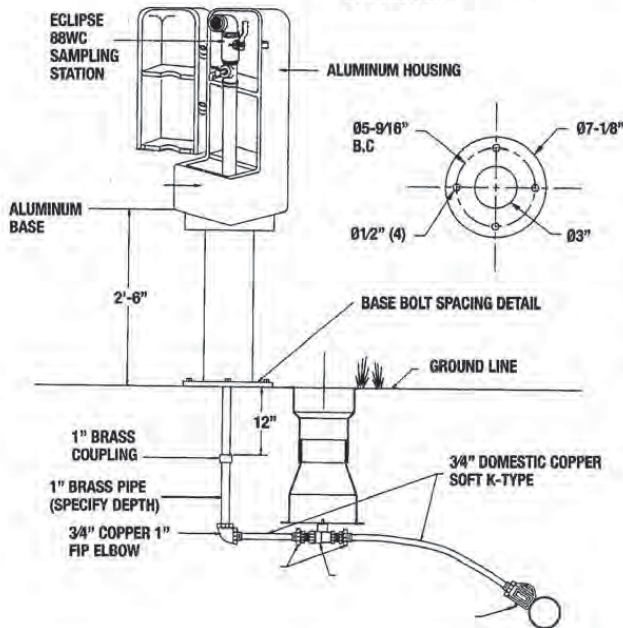

### #88WC On Pedestal Specifications

Sampling Stations shall be \_\_\_' bury, with a 1" MIP inlet, and a 1" FIP discharge. A 1/4" bent-nose sampling bibb shall be located before the discharge. All stations shall be enclosed in a lockable, nonremovable, aluminum-cast housing. Housing shall be on a 2'-6" pedestal with a 7-118" mounting flange. When opened, the station shall require no key for operation, and the water will flow in an all brass and serviceable from above ground with no digging.

A 1" ball valve will control the water flow, and be located before (or after) the sampling bibb, as manufactured by Kupferle Foundry, St. Louis, MO 63102.



# ECLIPSE NO. #88 SAMPLING STATION

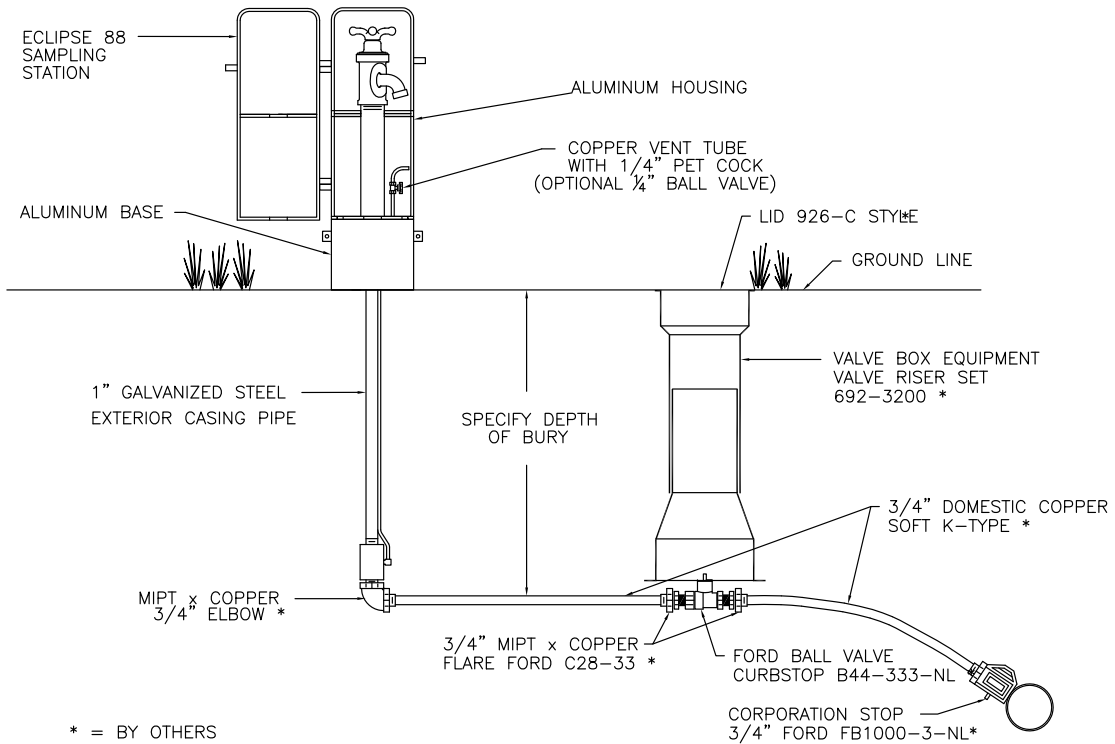

Sampling Stations shall be 4' bury, with a 3/4" FIP inlet, and a (3/4" hose or unthreaded) nozzle.

All stations shall be enclosed in a lockable, nonremovable, aluminum-cast housing.

When opened, the station shall require no key for operation, and the water will flow in an all brass waterway.

All working parts will also be of brass and be removable from above ground with no digging. Exterior piping shall be brass or galvanized.

A copper vent tube will enable each station to be pumped free of standing water to prevent freezing and to minimize bacteria growth.

Eclipse No. #88 Sampling Station shall be manufactured by Kupferle Foundry, St. Louis, MO 63102.

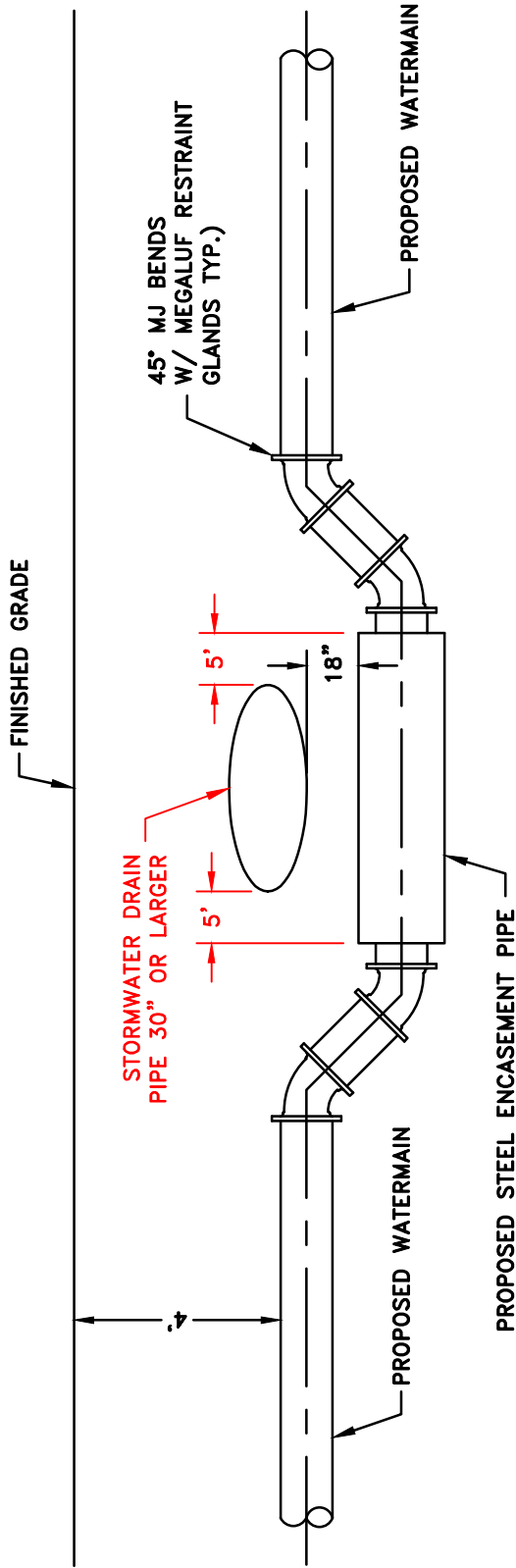

**TYPICAL WATERMAIN / STORMWATER CROSSINGS**

not to scale

STEEL ENCASEMENT PIPE W/DIP WATERMAIN, NEOPRENE END CAPS,  
 3 STAINLESS STEEL SPACERS PER 20' PIPE SECTION & FIELDLOK  
 RESTRAINT GASKETS (DIAMETER OF ENCASEMENT PIPE IS TO BE  
 8" LARGER THAN DIAMETER OF WATERMAIN). FIELDLOK GASKETS TO EXTEND  
 TWO (2) PIPE LENGTHS IN EITHER DIRECTION BEYOND UPPER 45° BENDS.

THIS DRAWING IS PROVIDED BY VEOLIA WATER PENNSYLVANIA FOR DISPLAY AND IS SUBJECT TO CHANGE WITHOUT NOTICE. NO CLAIMS, EITHER REAL OR ASSUMED AS TO ABSOLUTE OR RELATIVE ACCURACY OR PRECISION OF ANY DATA CONTAINED HEREIN ARE MADE BY VEOLIA WATER PENNSYLVANIA, NOR WILL THE COMPANY BE HELD RESPONSIBLE FOR ANY USE OF THIS DOCUMENT FOR PURPOSES OTHER THAN WHICH IT IS INTENDED.

NO.	REVISION	DATE
1	REVISED CLEARANCE BETWEEN STORM AND END OF ENCASEMENT PIPE & SIZE OF STORM FOR ENCASEMENT REQUIREMENTS	2024

DWG NAME

DWGNME1  
 DWGNME2



VEOLIA WATER PENNSYLVANIA  
 6310 ALLENTOWN BLVD  
 HARRISBURG, PENNSYLVANIA 17112

DRAWN BY

DRAWNBY

SCALE

SCALE

DATE

DATE

CAD FILE NAME

CADFILE



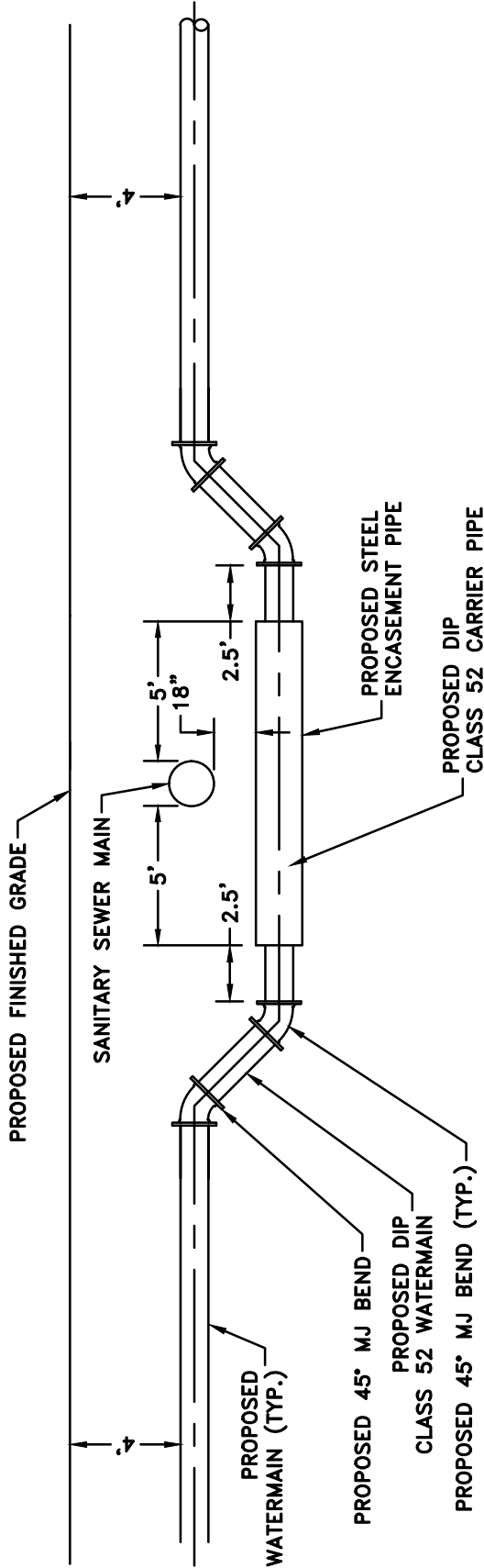

## TYPICAL WATERMAIN / SANITARY SEWER CROSSINGS

not to scale

STEEL ENCASUREMENT PIPE W/DIP WATERMAIN, NEOPRENE END CAPS, 3 STAINLESS STEEL SPACERS PER 20' PIPE SECTION & FIELDLOK RESTRAINT GASKETS (DIAMETER OF ENCASUREMENT PIPE IS TO BE 8" LARGER THAN DIAMETER OF WATERMAIN). FIELDLOK GASKETS TO EXTEND TWO (2) PIPE LENGTHS IN EITHER DIRECTION BEYOND UPPER 45° BENDS. SHUT-OFF VALVES SHOWN IN THE EVENT WATERMAIN CROSSES UNDER THE SANITARY SEWER LINE.

THIS DRAWING IS PROVIDED BY VEOLIA WATER PENNSYLVANIA FOR DISPLAY AND IS SUBJECT TO CHANGE WITHOUT NOTICE. NO CLAIMS, EITHER REAL OR ASSUMED AS TO ABSOLUTE OR RELATIVE ACCURACY OR PRECISION OF ANY DATA CONTAINED HEREIN ARE MADE BY VEOLIA WATER PENNSYLVANIA, NOR WILL THE COMPANY BE HELD RESPONSIBLE FOR ANY USE OF THIS DOCUMENT FOR PURPOSES OTHER THAN WHICH IT IS INTENDED.

NO.	REVISION	DATE
1	(2) - MJ VALVES REMOVED	2024

DWG NAME

PROPOSED WATERMAIN CROSSING  
SANITARY SEWER MAINS

DRAWN BY

DRP

SCALE

N.T.S.

DATE

11/02/24

CAD FILE NAME

SWPA-TYP DWG



VEOLIA WATER PENNSYLVANIA  
6310 ALLENTOWN BLVD  
HARRISBURG, PENNSYLVANIA 17112

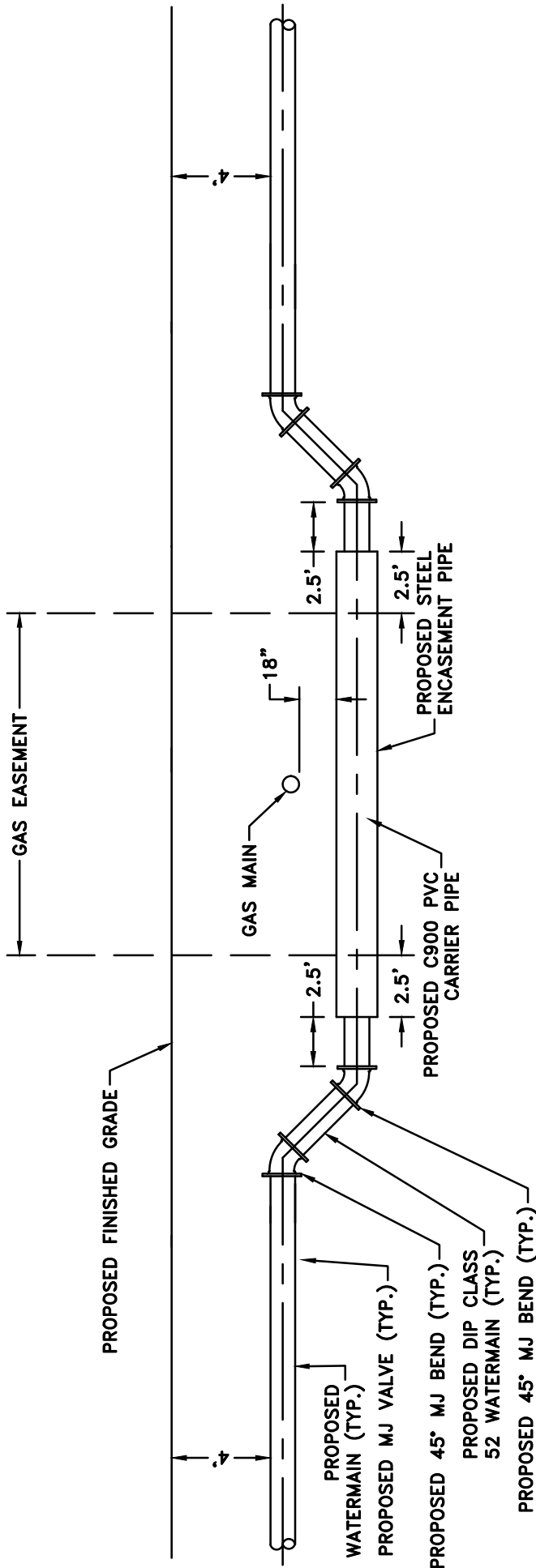

## TYPICAL WATERMAIN / HIGH PRESSURE GAS CROSSINGS

not to scale

STEEL ENCASUREMENT PIPE W/PVC WATERMAIN, NEOPRENE END CAPS,  
 3 STAINLESS STEEL SPACERS PER 20' PIPE SECTION & LOCKING  
 RESTRAINT GASKETS (DIAMETER OF ENCASUREMENT PIPE IS TO BE  
 8" LARGER THAN DIAMETER OF WATERMAIN)

THIS DRAWING IS PROVIDED BY VEOLIA WATER PENNSYLVANIA FOR DISPLAY AND IS SUBJECT TO CHANGE WITHOUT NOTICE. NO CLAIMS, EITHER REAL OR ASSUMED AS TO ABSOLUTE OR RELATIVE ACCURACY OR PRECISION OF ANY DATA CONTAINED HEREIN ARE MADE BY VEOLIA WATER PENNSYLVANIA, NOR WILL THE COMPANY BE HELD RESPONSIBLE FOR ANY USE OF THIS DOCUMENT FOR PURPOSES OTHER THAN WHICH IT IS INTENDED.

NO.	REVISION	DATE
1	PVC WATERMAIN	2023
1	(2) - MJ VALVES REMOVED	2024

 <small>VEOLIA WATER PENNSYLVANIA          6310 ALLENTOWN BLVD          HARRISBURG, PENNSYLVANIA 17112</small>		<b>DWG NAME</b> PROPOSED WATERMAIN CROSSING HIGH PRESSURE NATURAL GAS MAINS
<b>DRAWN BY</b> DRP	<b>SCALE</b> N.T.S.	<b>DATE</b> 11-27-17
		<b>CAD FILE NAME</b> SWPA-TYP DWG

**2024 APPROVED MATERIAL LIST**

ITEM	SPECIFICATIONS			MANUFACTURER
<b>TAPPING SLEEVES</b>	Stainless Steel w/ MJ outlet, Ford Fast style(required for AC, PVC,DI pipe applications); Cast Iron (required for Cast Iron pipe applications)			FORD, ROMAC
	Pack joint, 1/4" Turn, ball valve, no plug types			MUELLER, FORD
	<b>DESCRIPTION</b>	<b>MUELLER</b>	<b>FORD</b>	
	2" Corp	P25008-N-NL	FB1000-7-NL	MUELLER, FORD
	2" Curb Stop PAC/PAC	P25209-2-NL	B44-777-NL	MUELLER, FORD
	2" Insert	528707	INSERT #55	MUELLER, FORD
<b>CORB &amp; CURB STOPS</b>				
	1" Corp	P25008-1-NL	FB1000-4-NL	MUELLER, FORD
	1" Curb Stop PAC/PAC	P25209-1-NL	B44-444-NL	MUELLER, FORD
	1" Insert	528705	INSERT #52	MUELLER, FORD
	3/4" Corp			
	3/4" Curb Stop PAC/PAC	P25008-3/4-NL	FB1000-3-NL	MUELLER, FORD
	3/4" Insert	P25209-3/4-NL	B44-333-NL	MUELLER, FORD
<b>SADDLES</b>	Epoxy Coated with S.S. band: Wide bands AC and PVC Pipe), narrow bands (CI and DI Pipe)			FORD
<b>SERVICE TUBING</b>	Type K Copper 200 PSI rated - CTS Size PE			VARIOUS
<b>MANIFOLDS</b>	U-Branch connections (threaded) / required for double services; twelve inch minimum spread between curb stops;	U48-43-12.5-NL		FORD
	refer to Typical Drawing section of Veolia Specifications			
<b>SERVICE BEDDING</b>	Silica Sand			VARIOUS
<b>VALVE BOXES</b>	Cast Iron Valve Box			VARIOUS
<b>VALVE BOX ADAPTOR</b>	Rubber adaptor to align valve box on valve			ADAPTOR INC.
	<b>CONCRETE PAVED AREAS</b>			
<b>SERVICE BOXES</b>	Street rated Erie Style with recessed lid			VARIOUS
	<b>NON- PAVED AREAS</b>			
	Erie Style with Stainless Steel Rod			VARIOUS
<b>EXTENDED RANGE COUPLING</b>	Stainless steel bolts and nuts			VARIOUS

**2024 APPROVED MATERIAL LIST**

ITEM	SPECIFICATIONS	MANUFACTURER
DI PIPE	Ductile Iron, Class 52, Tyton Joint, Fastite, Cement Lined.	VARIOUS
PIPE BEDDING	2A Modified (1B and 2A is not acceptable)	VARIOUS
LOCATE WIRE	10 Gauge, Blue Coating, Continuous run, loop up through roadway box to allow for instrument connection	VARIOUS
FITTINGS, BENDS	DI, MJ, Cement Lined	SIGMA, TYLER
GATE VALVE HARRISBURG, DALLAS AND MECHANICSBURG OPERATIONS	Ductile Iron Body, 350 psi rated, or Cast Iron Body 250 psi rated stainless steel bolts and nuts, resilient seated open LEFT, No Lead	AFC, CLOW, MUELLER/US PIPE
GATE VALVE BLOOMSBURG OPERATION	Ductile Iron Body, 350 psi rated, or Cast Iron Body 250 psi rated stainless steel bolts and nuts, resilient seated open RIGHT, No Lead	AFC, CLOW, MUELLER/US PIPE
FIRE HYDRANT HARRISBURG, DALLAS OPERATION	Fire Hydrant SHOE, 5-1/4", VO, MJ 4'-6" Bury, Catalog # 423-529689, A-423 5-1/4" CENTURION OL 3-WAY 2-2-1/2" HOSE NOZ GA NS, 1-5" SNAP-TITE STORZ PUMPER 1-1/2" PENT OPEN LEFT, 6" HYMAX SHOE RED W/ "NS" STENCILED IN WHITE, NO LEAD	MUELLER
FIRE HYDRANT BLOOMSBURG OPERATION	Fire Hydrant SHOE, 5-1/4", VO, MJ 4'-6" Bury, Catalog # 423-529689, A-423, 5-1/4" CENTURION OR 3-WAY, 2-2-1/2" HOSE NOZ GA NS, 1-5" SNAP-TITE STORZ PUMPER, 1-3/16" SQUARE OPERATING NUT OPEN LEFT 6" HYMAX SHOE RED W/ WHITE VBONNET AND CAPS W/ "NS" STENCILED IN WHITE, NO LEAD	MUELLER
FIRE HYDRANT MECHANICSBURG OPERATION	Fire Hydrant SHOE, 5-1/4", VO, MJ 4'-6" Bury, Catalog # 423-529689, A-423 5-1/4" CENTURION OL 3-WAY 2-2-1/2" HOSE NOZ GA NS, 1-5" SNAP-TITE STORZ PUMPER 1-1/2" PENT OPEN LEFT, 6" HYMAX SHOE RED W/ "NS" STENCILED IN WHITE, NO LEAD	MUELLER

2024 APPROVED MATERIAL LIST

Veolia Water Pennsylvania Inc.  
Meter Pit Part Number Specification

METER SIZE	PIT SETTER CAT. #	PIT COVER FRAME CAT. #	PIT LID CAT. # Trumbull Industries Inc	Specification Detail Page #
5/8" x 3/4"	AY McDonald 780W248WDPP 33X18X970 NO LEAD	AY McDonald: 74MWF18 FRAME ONLY-1PE-18PIT	367-5518 w/Itron 100W+ ERT Bracket	17
5/8" x 3/4" PRV Meter Pit	AY McDonald 782W248QFPP 33X21X970 NO LEAD	AY McDonald: 74MWF21 FRAME ONLY-1PE-21PIT	367-5518 W/ Itron 100W ERT BRACKET	18
3/4"	AY McDonald 780W348WDPP 33X21X970 NO LEAD	AY McDonald 74MWF21 FRAME ONLY-1 PCE-21 PIT	367-5518 w/Itron 100W+ ERT Bracket	19
3/4" - PRV Meter Pit	AY McDonald 780W348WDPP 33X18X970 NO LEAD	AY McDonald 74MWF18 FRAME ONLY-1 PCE-18 PIT	367-5518 w/Itron 100W+ ERT Bracket	20
1"	AY McDonald 80W448WDPP 44X21 NO LEAD	AY McDonald 74MWF21 FRAME ONLY-1 PCE-21 PIT	367-5518 w/Itron 100W+ ERT Bracket	21
1-1/2"	Ford PDBHH-688-36HB-48-NL	Ford MONITOR FRAME ONLY	367-5610 w/Itron 100W+ ERT Bracket	22
2"	Ford PDBHH-788-36HB-48-NL	Ford MONITOR FRAME ONLY	367-5610 w/Itron 100W+ ERT Bracket	23

Revised 01/2024  
This replaces all lists prior to the revision date  
\*URR METER PIT

**VEOLIA WATER PENNSYLVANIA, INC.**

**DEVELOPER PROJECT "PRELIMINARY" COST SUMMARY**

Contractor: \_\_\_\_\_

Project ID: \_\_\_\_\_

Project No.: \_\_\_\_\_



**1. WATERMAIN MATERIALS & INSTALLATION**

(Note: water main material costs to include pipe, fittings, tapping sleeves, concrete, locate tape, locate wire, stone bedding, blow-off assemblies w/ valve boxes.)

TYPE	SIZE (IN)	QUANTITY	MATERIAL COST	LABOR COST	TOTAL
PET	2				\$ -
DIP	4				\$ -
DIP	6				\$ -
DIP	8				\$ -
DIP	10				\$ -
DIP	12				\$ -
Other					\$ -
<b>WATERMAIN TOTAL</b>					<b>\$ -</b>

**2. VALVES MATERIALS & INSTALLATION**

(Note: Includes gate valves and roadway boxes other than those associated with fire hydrants.)

ITEM	SIZE (IN)	QUANTITY	MATERIAL COST	LABOR COST	TOTAL
Valve	2				\$ -
Valve	4				\$ -
Valve	6				\$ -
Valve	8				\$ -
Valve	10				\$ -
Valve	12				\$ -
Valve					\$ -
<b>VALVES TOTAL</b>					<b>\$ -</b>

**3. SERVICES**

(Note: service material costs to include both long-sided and short-sided taps, corps, 3/4" and 1" type "K" copper, curb stops, curb boxes and manifolds.)

ITEM	SIZE (IN)	QUANTITY	MATERIAL COST	LABOR COST	TOTAL
Service	3/4				\$ -
Service	1				\$ -
Service	2				\$ -
Fire Service					\$ -
Other					\$ -
<b>SERVICES TOTAL</b>					<b>\$ -</b>

**4. FIRE HYDRANTS**

(Note: fire hydrant assembly to include hydrant, 6" gate valve and roadway box, tee, 6" pipe, concrete and threaded rod.)

ITEM	QUANTITY	MATERIAL COST	LABOR COST	TOTAL
Fire Hydrants				\$ -
<b>FIRE HYDRANT TOTAL</b>				<b>\$ -</b>

**PROJECT SUMMARY**

DESCRIPTION	TOTAL
1. WATERMAIN MATERIALS & INSTALLATION	\$ -
2. VALVES MATERIALS & INSTALLATION	\$ -
3. SERVICES	\$ -
4. FIRE HYDRANTS	\$ -
<b>TOTAL PRELIMINARY COST SUMMARY</b>	
	<b>\$ -</b>

Company Name: \_\_\_\_\_

Print Name: \_\_\_\_\_

Title: \_\_\_\_\_

Signature: \_\_\_\_\_

Date: \_\_\_\_\_

**VEOLIA WATER PENNSYLVANIA, INC.**

**DEVELOPER PROJECT "FINAL" COST SUMMARY**

Contractor:

Project ID:

Project No.:



**1. WATERMAIN MATERIALS & INSTALLATION**

(Note: water main material costs to include pipe, fittings, tapping sleeves, concrete, locate tape, locate wire, stone bedding, blow-off assemblies w/ valve boxes.)

TYPE	SIZE (IN)	QUANTITY	MATERIAL COST	LABOR COST	TOTAL
PET	2				\$ -
DIP	4				\$ -
DIP	6				\$ -
DIP	8				\$ -
DIP	10				\$ -
DIP	12				\$ -
Other					\$ -
<b>WATERMAIN TOTAL</b>					<b>\$ -</b>

**2. VALVES MATERIALS & INSTALLATION**

(Note: Includes gate valves and roadway boxes other than those associated with fire hydrants.)

ITEM	SIZE (IN)	QUANTITY	MATERIAL COST	LABOR COST	TOTAL
Valve	2				\$ -
Valve	4				\$ -
Valve	6				\$ -
Valve	8				\$ -
Valve	10				\$ -
Valve	12				\$ -
Valve					\$ -
<b>VALVES TOTAL</b>					<b>\$ -</b>

**3. SERVICES**

(Note: service material costs to include both long-sided and short-sided taps, corps, ¾" and 1" type "K" copper, curb stops, curb boxes and manifolds.)

ITEM	SIZE (IN)	QUANTITY	MATERIAL COST	LABOR COST	TOTAL
Service	3/4				\$ -
Service	1				\$ -
Service	2				\$ -
Fire Service					\$ -
Other					\$ -
<b>SERVICES TOTAL</b>					<b>\$ -</b>

**4. FIRE HYDRANTS**

(Note: fire hydrant assembly to include hydrant, 6" gate valve and roadway box, tee, 6" pipe, concrete and threaded rod.)

ITEM	QUANTITY	MATERIAL COST	LABOR COST	TOTAL
Fire Hydrants				\$ -
<b>FIRE HYDRANT TOTAL</b>				<b>\$ -</b>

**PROJECT SUMMARY**

DESCRIPTION	TOTAL
1. WATERMAIN MATERIALS & INSTALLATION	\$ -
2. VALVES MATERIALS & INSTALLATION	\$ -
3. SERVICES	\$ -
4. FIRE HYDRANTS	\$ -
<b>TOTAL FINAL COST SUMMARY</b>	
	<b>\$ -</b>

Company Name:

Print Name:

Title:

Signature:

Date:

**Project Name:** Example 2024 Project  
**Project ID No.:** Example 123  
**Area:** Example Area  
**Contractor:** Example contractor  
**Date:** 1/1/2023

**Instructions:**  
 Contractor to populate the highlighted Unit Price cells below.

**BASE BID ITEMS**

Item	Description	Units	Est. Qty	Unit Price	Total
<b>1</b>	<b>WATERMAIN INSTALLATION</b>				
	<i>Note: Contractor to supply concrete, locate tape, stone bedding, temporary and final trench restoration (i.e. pavement, sidewalk, &amp; grass area restoration).</i>				
a.	1" PET Watermain	LF		\$ -	\$ -
b.	2" PET Watermain	LF		\$ -	\$ -
c.	4" DIP Watermain	LF		\$ -	\$ -
d.	6" DIP Watermain	LF		\$ -	\$ -
e.	8" DIP Watermain	LF		\$ -	\$ -
f.	10" DIP Watermain	LF		\$ -	\$ -
g.	12" DIP Watermain	LF		\$ -	\$ -
h.	16" DIP Watermain	LF		\$ -	\$ -
i.	24" DIP Watermain	LF		\$ -	\$ -
<b>2</b>	<b>VALVE INSTALLATION</b>				
a.	1" Valve & Box	EA		\$ -	\$ -
b.	2" Valve & Box	EA		\$ -	\$ -
c.	4" Valve & Box	EA		\$ -	\$ -
d.	6" Valve & Box	EA		\$ -	\$ -
e.	8" Valve & Box	EA		\$ -	\$ -
f.	10" Valve & Box	EA		\$ -	\$ -
g.	12" Valve & Box	EA		\$ -	\$ -
h.	16" Valve & Box	EA		\$ -	\$ -
i.	24" Valve & Box	EA		\$ -	\$ -
<b>3</b>	<b>REPLACEMENT SERVICES - INSTALLATION</b>				
	<i>Note: Contractor to supply silica sand bedding, customer-side service line connection and restoration.</i>				
a.	3/4" Replacement Water Service	EA		\$ -	\$ -
b.	1" Replacement Water Service	EA		\$ -	\$ -
c.	2" Replacement Water Service	EA		\$ -	\$ -
d.	Other (specify)	EA		\$ -	\$ -
e.	Other (specify)	EA		\$ -	\$ -
f.	Other (specify)	EA		\$ -	\$ -
g.	Other (specify)	EA		\$ -	\$ -
h.	Other (specify)	EA		\$ -	\$ -
<b>4</b>	<b>METER PITS - INSTALLATION</b>				
	<i>Note: Contractor to supply stone bedding and restoration.</i>				
a.	3/4" New Meter Pit	EA		\$ -	\$ -
b.	1" New Meter Pit	EA		\$ -	\$ -
c.	2" New Meter Pit	EA		\$ -	\$ -
<b>5</b>	<b>FIRE HYDRANTS - INSTALLATION</b>				
	<i>Note: Where indicated on plan, includes installation of supplied fire hydrant, valve, fire hydrant tee &amp; connecting piping; and Contractor supplied stone, concrete, rodding, etc.</i>				
a.	Replacement Fire Hydrant	EA		\$ -	\$ -
<b>6</b>	<b>FINAL RESTORATION (BASE BID ESTIMATE - OUTSIDE OF TRENCH)</b>				
	<i>Note: Estimated quantities based upon anticipated local/state requirements for areas outside of the pipe trench.</i>				
a.	Concrete Sidewalk	CY		\$ -	\$ -
b.	Bituminous Base	TON		\$ -	\$ -
c.	Bituminous Wearing	TON		\$ -	\$ -
d.	Milling	SF		\$ -	\$ -

ITEM	PROJECT SUMMARY - BID ITEMS 1 - 6	TOTAL
1	Watermain	\$ -
2	Valves	\$ -
3	Services	\$ -
4	Meter Pits	\$ -
5	Fire Hydrants	\$ -



<b>6</b>	Final Restoration - Base Bid	\$	-
	<b>LUMP SUM TOTAL</b>	<b>\$</b>	<b>-</b>

**ADD ALTERNATE BID ITEMS**

Item	Description	Units	Est. Qty	Unit Price	Total
<b>7</b>	<b>FINAL RESTORATION - ADD/ALT</b>				
	a. Concrete Sidewalk	CY		\$ -	\$ -
	b. Bituminous Base	TON		\$ -	\$ -
	c. Bituminous Wearing	TON		\$ -	\$ -
	d. Milling	SF		\$ -	\$ -
<b>8</b>	<b>EXTRA DEPTH EXCAVATION - ADD/ALT</b>				
	a. Extra Depth Excavation	CY		\$ -	\$ -
<b>9</b>	<b>NEW FIRE HYDRANT - ADD/ALT</b>				
	a. New Fire Hydrant	EA		\$ -	\$ -
<b>10</b>	<b>NEW DOMESTIC SERVICES - ADD/ALT</b>				
	a. 3/4" Short Side	EA		\$ -	\$ -
	b. 1" Short Side	EA		\$ -	\$ -
	c. 2" Short Side	EA		\$ -	\$ -
	d. 3/4" Long Side	EA		\$ -	\$ -
	e. 1" Long Side	EA		\$ -	\$ -
	f. 2" Long Side	EA		\$ -	\$ -
<b>11</b>	<b>METER PITS - ADD/ALT</b>				
	a. 3/4" Meter Pit	EA		\$ -	\$ -
	b. 1" Meter Pit	EA		\$ -	\$ -
	c. 1.5" Meter Pit	EA		\$ -	\$ -
	d. 2" Meter Pit	EA		\$ -	\$ -

EXAMPLE

# Change Order Request Form



Summarize Change Request, contractor to populate highlighted cells only

Project Name:	
Veolia Project No.:	
Vendor Name:	
Submission Date:	

Change Order No: \_\_\_\_\_

Describe Change:

Amount: \$ \_\_\_\_\_ -

Change Order requests require advance approval from authorized Company representative. Company Representative for this Change Order shall be:

Name: \_\_\_\_\_

Title: \_\_\_\_\_

Indicate All Deliverables and due dates:

Veolia Water Pennsylvania Inc.			
Print name:		Print name:	
Title:		Title:	
Signature:		Signature:	
Witness:		Witness:	
Date:		Date:	

R 11/16/22





PROJECT:

APPLICATION NO:

Distribution to:

<input type="checkbox"/>	OWNER
<input type="checkbox"/>	ARCHITECT
<input type="checkbox"/>	CONTRACTOR
<input type="checkbox"/>	
<input type="checkbox"/>	

PERIOD TO:

VIA ARCHITECT:

PROJECT NOS:

CONTRACT DATE:

CONTRACT FOR:

CONTRACTOR'S APPLICATION FOR PAYMENT

Application is made for payment, as shown below, in connection with the Contract. Continuation Sheet, AIA Document G703, is attached.

The undersigned Contractor certifies that to the best of the Contractor's knowledge, information and belief the Work covered by this Application for Payment has been completed in accordance with the Contract Documents, that all amounts have been paid by the Contractor for Work for which previous Certificates for Payment were issued and payments received from the Owner, and that current payment shown herein is now due.

- ORIGINAL CONTRACT SUM \$ 0.00
- Net change by Change Orders \$ 0.00
- CONTRACT SUM TO DATE (Line 1 + 2) \$ 0.00
- TOTAL COMPLETED & STORED TO DATE (Column G on G703) \$ 0.00
- RETAINAGE:
  - % of Completed Work (Column D + E on G703) \$ 0
  - % of Stored Material (Column F on G703) \$
- TOTAL EARNED LESS RETAINAGE (Line 4 Less Line 5 Total) \$ 0.00
- LESS PREVIOUS CERTIFICATES FOR PAYMENT (Line 6 from prior Certificate) \$ 0.00
- CURRENT PAYMENT DUE (Line 3 less Line 6) \$ 0.00
- BALANCE TO FINISH, INCLUDING RETAINAGE (Line 3 less Line 6) \$

CONTRACTOR:

By: \_\_\_\_\_ Date: \_\_\_\_\_

State of: \_\_\_\_\_ County of: \_\_\_\_\_

Subscribed and sworn to before me this \_\_\_\_\_ day of \_\_\_\_\_

Notary Public: \_\_\_\_\_

My Commission expires: \_\_\_\_\_

ARCHITECT'S CERTIFICATE FOR PAYMENT

In accordance with the Contract Documents, based on on-site observations and the data comprising the application, the Architect certifies to the Owner that to the best of the Architect's knowledge, information and belief the Work has progressed as indicated, the quality of the Work is in accordance with the Contract Documents, and the Contractor is entitled to payment of the AMOUNT CERTIFIED.

AMOUNT CERTIFIED .....\$ \_\_\_\_\_

(Attach explanation if amount certified differs from the amount applied. Initial all figures on this Application and on the Continuation Sheet that are changed to conform with the amount certified.) ARCHITECT:

By: \_\_\_\_\_ Date: \_\_\_\_\_

This Certificate is not negotiable. The AMOUNT CERTIFIED is payable only to the Contractor named herein. Issuance, payment and acceptance of payment are without prejudice to any rights of the Owner or Contractor under this Contract.

CHANGE ORDER SUMMARY	ADDITIONS	DEDUCTIONS
Total changes approved in previous months by Owner		
Total approved this Month		
TOTALS	\$0.00	\$0.00
NET CHANGES by Change Order	\$0.00	



	TASK ORDER FORM	
--	-----------------	--

**TASK ORDER**

**Date:** 1/1/2024

**Agreement #:** XXXX

**Contractor/Consultant Name:** Example

**Project Name:** Example

**Scope of Services and Deliverables:** Example Description

**Deliverable Due Date Schedule:** 1/1/2024

**Estimated Task Order amount:** \$1.00

**Consultant/Contractor is not to exceed the Task Order amount without advance approval of Company representative.**

**Company Representative for this Task Order shall be:** XXXX

**Consultant/Contractor Representative for this Task Order shall be:** XXXX

	Applicable	Not Applicable
Contract Client:	<input type="checkbox"/>	<input checked="" type="checkbox"/>
Performance Bond	<input type="checkbox"/>	<input checked="" type="checkbox"/>
Payment Bond	<input type="checkbox"/>	<input checked="" type="checkbox"/>
Retainage	<input checked="" type="checkbox"/>	<input type="checkbox"/>
Prevailing Wages	<input type="checkbox"/>	<input checked="" type="checkbox"/>

IN WITNESS WHEREOF, the parties hereto have executed this Task Order as of the date above written.

<b>Veolia Water Pennsylvania Inc.</b>	<b>XXXX</b>
Print Name:	Print Name:
Title:	Title:
Signature:	Signature:
Witness:	Witness:
Date:	Date:

	<b>MASTER SERVICES AGREEMENT - CONSTRUCTION</b>	
--	---	--

**SCHEDULE C**

**CERTIFICATE AND RELEASE OF LIEN**

*(to be executed by Contractor and to accompany all payment requests)*

The undersigned, in consideration of the payment in the amount of \$ \_\_\_\_\_, hereby waives and releases its lien and right to claim a lien for labor, services or materials furnished through \_\_\_\_\_, 20\_\_ to Veolia Water \_\_\_\_\_ ("Veolia Water") or ("Company") for the benefit of Veolia Water pursuant to the Agreement between Contractor and Veolia Water dated \_\_\_\_\_ ("Agreement"). Contractor hereby certifies that all of its subcontractors under the Agreement have been paid for labor, services furnished through the date hereof in connection with the above project. Contractor hereby agrees to indemnify, defend and hold harmless the Company, its affiliates, officers, directors and agents against any claims or liens from such subcontractors arising out of the Agreement or the Work.

Dated: \_\_\_\_\_

Contractor: \_\_\_\_\_

\_\_\_\_\_  
Name:

Title:

Address: \_\_\_\_\_

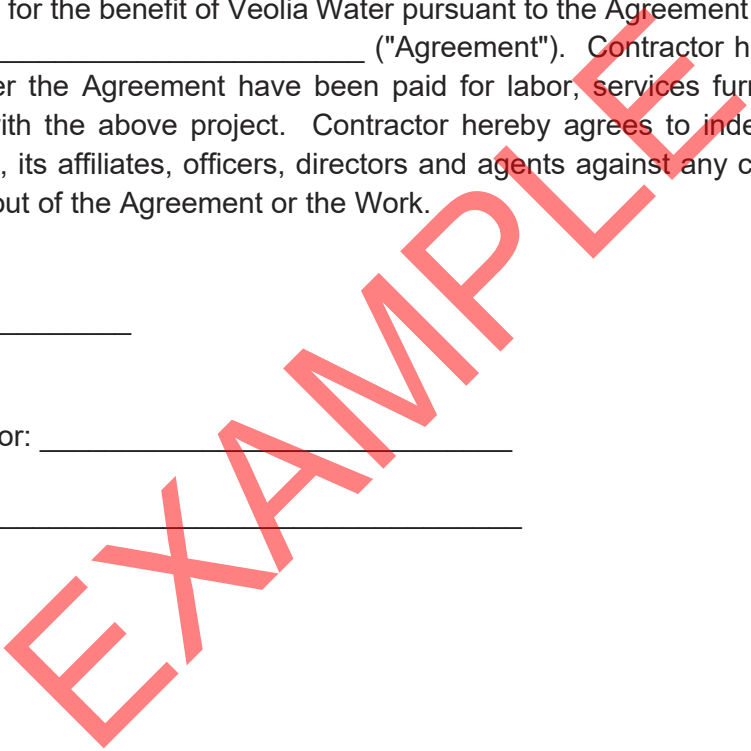



## 2024 GPS DIRECTIONS

1. The As-Built is to be produced by the Contractor using GPS collection equipment as described below. The GPS As-Built Coordinates shall be collected and transmitted in “real time” and shall indicate the exact location and elevation of all facilities installed, prior to backfilling. Facilities shall include all pipe joints, fittings, valves, fire hydrants, hydrant valves, corporation stops, curb stops, blow-offs, air release valves, meter pits/vaults, and Water Main Points. Water Main points shall be collected at intervals no greater than fifty (50) feet.
2. The record of service spreadsheet shall be delivered to the company representative at the project closeout.
3. The following equipment and licenses will be required for GPS Collection
  - A. GNSS Bluetooth Receiver (make and model agnostic) – must be capable of at least centimeter collection, and must be compatible with ArcGIS Field Maps. VEOLIA recommends Trimble R2 receiver(with Trimble Mobile Manager) or EOS Arrow Gold receiver (with EOS Pro Tools applications)
  - B. An annual RTK subscription for centimeter accuracy GPS collection. This license is \$1,000/year. More information regarding purchasing this subscription should be available from your GPS vendor
  - C. iPad mobile devices with cellular data plan are recommended, however any mobile device can be used that supports ArcGIS Field Maps & connectivity to GNSS Bluetooth Receiver (and associated support applications)
  - D. Contractors should download ArcGIS Field Maps (Collector support ended 12/31/21)
  - E. ESRI ArcGIS Online “Creator” level ArcGIS Online License (±\$500 annual subscription)  
<https://www.esri.com/en-us/arcgis/products/arcgis-online/buy>
4. *The contractor shall provide the ArcGIS Online Username to Veolia Pennsylvania GIS team once obtained from ESRI. The GIS team will add your company to the VEOLIA PA Contractors mapping group. Contact Veolia Pennsylvania to setup a training session if necessary. Training may be provided by VEOLIA or the equipment vendor. **\*\*Important: All points must be collected in real time (prior to backfilling) as the water network is installed\*\*\****
5. *GPS As-Built will replace red-line drawings*

# Trimble R2 Setup Guide

## with Esri Field Maps Application

(v1.0 – December 2021)

### Download the latest versions of these applications:

1. Esri Field Maps (Application that is replacing the Esri Collector App)
2. Trimble Mobile Manager (TMM) (TMM replaces the GNSS Status App and is used to configure RTK settings for connection between Esri Field Maps and the Trimble R2 GPS Receiver)
  - a. Create a user account for TMM, if you have not done so already.
  - b. Alternately, you can use the Apple ID assigned to the device (one less username and password to remember).

### Setting up the GPS Receiver with your iPad/iPhone

1. Go to the Settings menu on your iPad/iPhone and select Bluetooth and turn on the Bluetooth radio button and let the device discover your Arrow receiver.
2. Tap the Trimble R2 Receiver you want to connect to in the ‘MY DEVICES’ list and wait a few seconds for the two to pair and connect.

*\*Ensure the Trimble R2 receiver status updates from “Not Connected” to “Connected”\**

### Configuring the R2 in Trimble Mobile Manager (TMM)

1. Open the Trimble Mobile Manager on your iPad/iPhone and sign in using the account you created above.
2. In TMM, click on Home and “Select Position Source” then choose to connect to Trimble R2.
3. Click the hamburger (3 lines top left corner) and select GNSS Configuration then choose Custom Local for the GNSS correction source.
4. Update the remaining GNSS server settings using the information below.
  - a. Your ‘Server Account’ Username and Password is located on the label placed on your R2 GPS receiver (Example: evsm151.....)

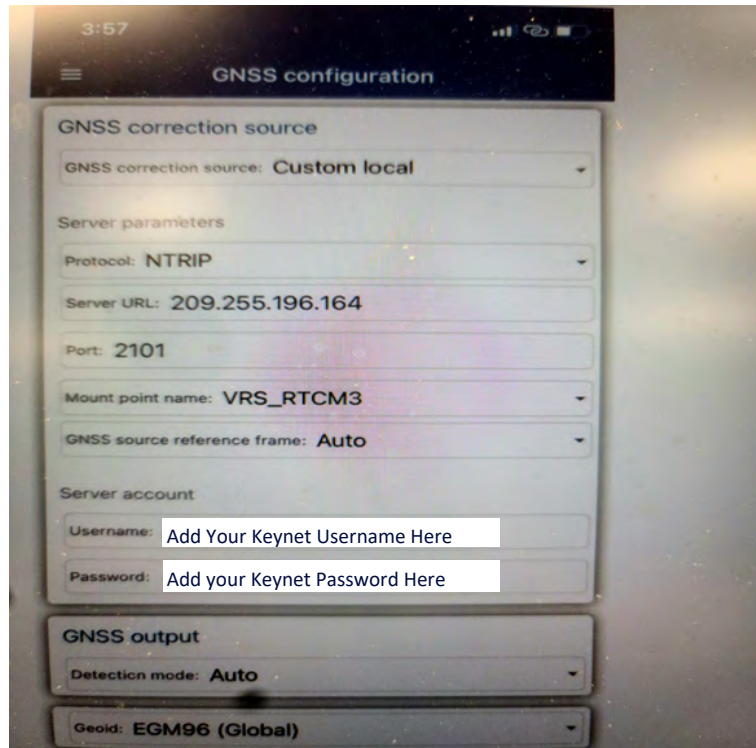

## Setting up the GPS Receiver with the Field Maps

1. Open the Field Maps Application using the following icon on your iPad/iPhone and sign in using your network single sign-on credentials

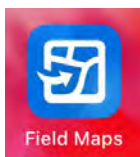

2. In the top left corner of your screen, select the small 'person' symbol to open your individual Profile settings

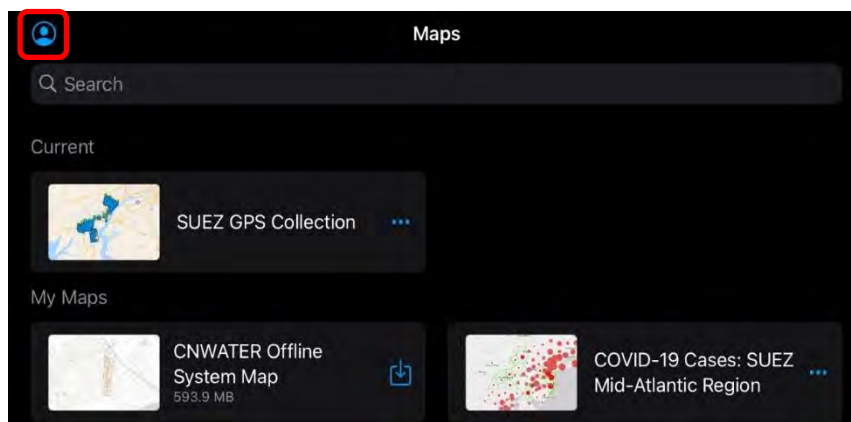

3. The following steps will guide you through the configuration needed for the 'Collection', 'Provider' and 'Profile' settings

a. Collection settings

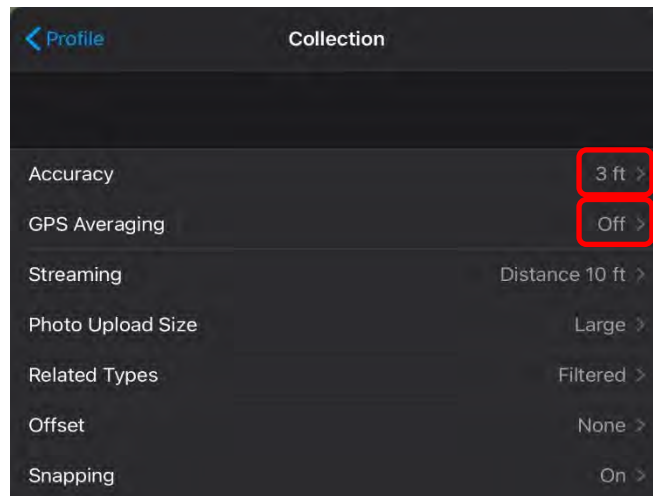

b. Provider settings

i. Tap on 'Add' to add your Arrow Receiver to the list of location providers

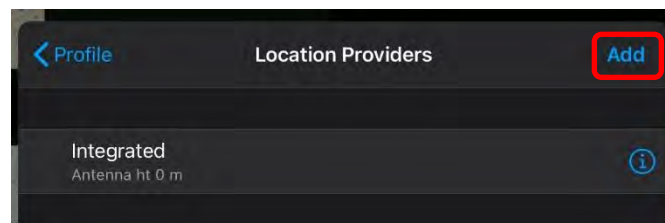

ii. Select your R2 Receiver. Once added to the list of location providers, be sure to tap the name of your receiver again so the blue check moves next to your selected receiver name as shown below.

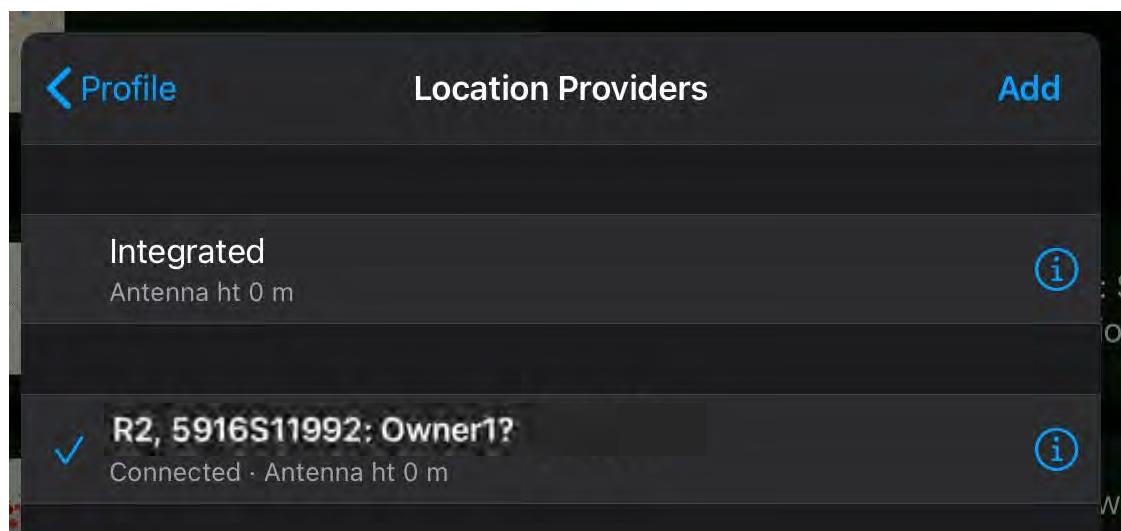

c. Profile settings

i. Tap on 'Add' to add the appropriate Profile settings

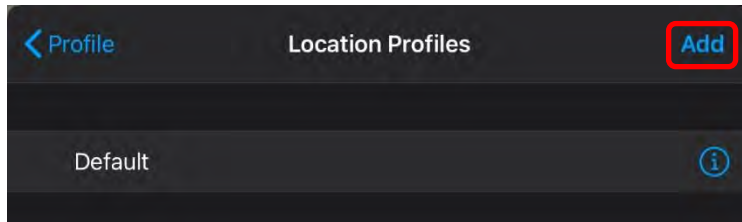

ii. Set the following three values as seen in the screenshot and name the profile "R2" and tap 'Done'.

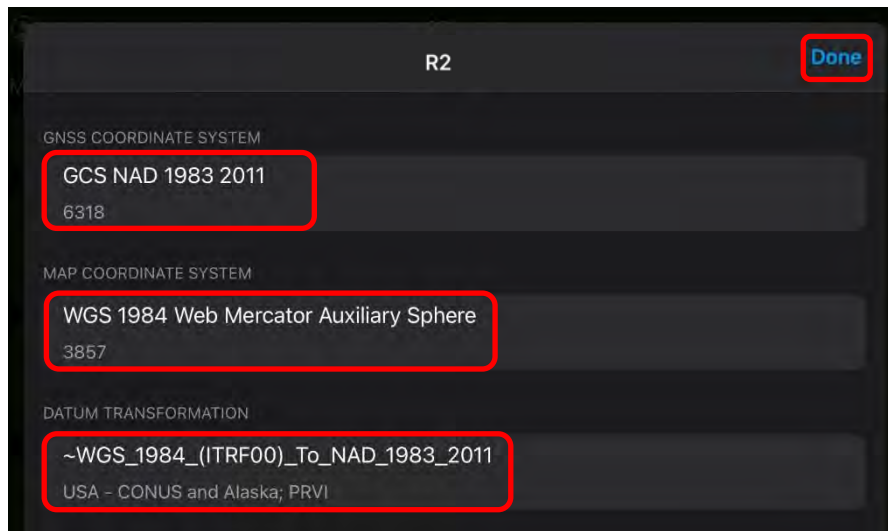

iii. Tap on the "Primary" profile you just created and ensure the blue check moves next to the "Primary" profile name.

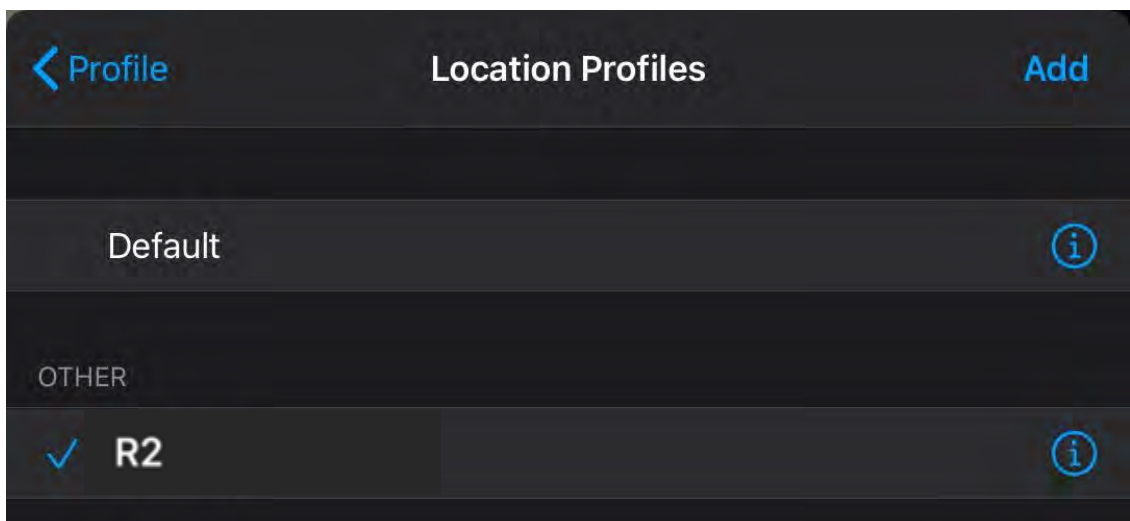

# Establish GPS position on the map

1. Go back to the GPS collection map and tap the blue arrow at the top right corner of your map. Your GPS will now connect. Once connected your accuracy should be displayed. Note: Your accuracy is required to be below 3 feet in order to collect a GPS point.

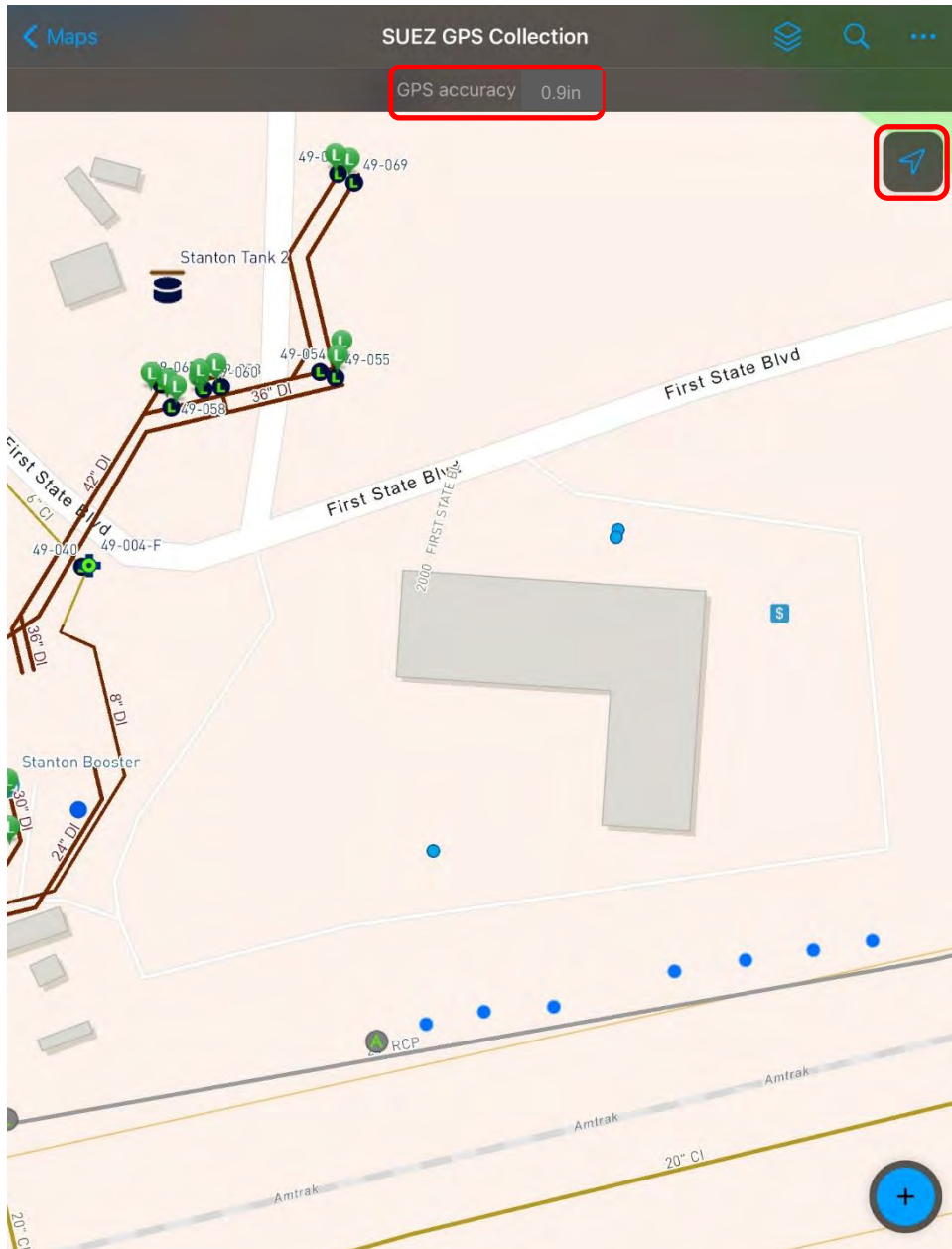



## Having trouble getting accuracy below 3 feet?

First try closing Collector by double pressing the home button and swiping up on the App you would like reopen Collector, ensure the R2 is still connected via Bluetooth in the iPad settings and the Collector Pro

*Accuracy is still no better?*

Next, you can try re-setting the mount point. Please note, you will need the R2 KeyNet username and pas perform this reset.

Open the Collector App and go to Profile Settings Click on “Provider” to expand Settings

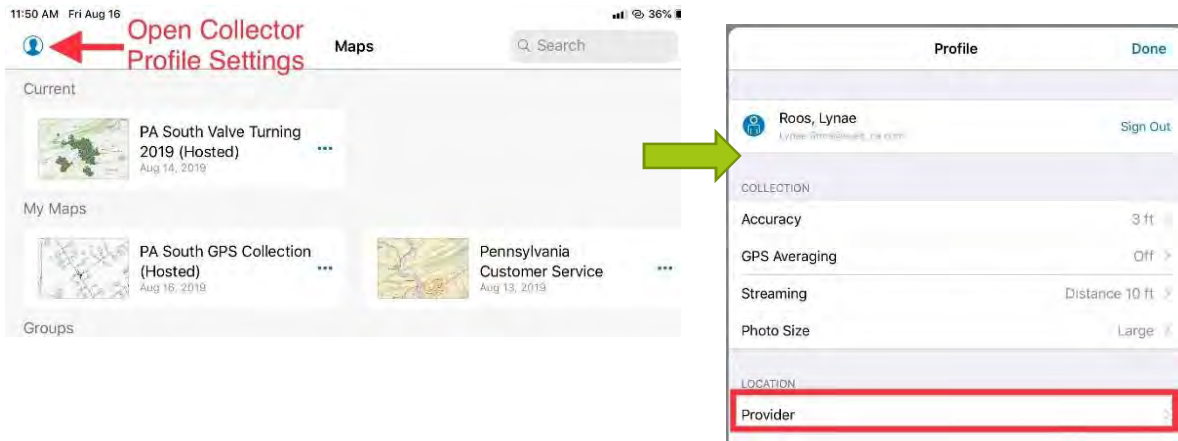

Click on the “i” inside the circle to edit the “Mount Point”

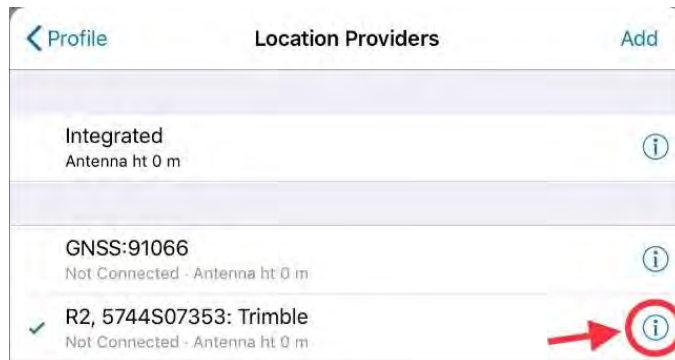

Change your “Mount Point” to either of the following two options

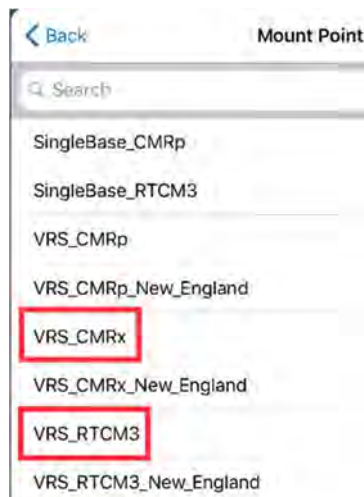

# Developer Package

For Non-Bona Fide Customer





## STEPS FOR DEVELOPER PROJECTS



## VEOLIA REQUIRED STEPS FOR DEVELOPER PROJECTS

---

The following is the procedure for the installation of a water network and facilities for a new Developer project within the Veolia Water Pennsylvania, Inc. (Veolia) Certificated Service Area. The Items are listed in the order required for the project to progress.

### ABILITY TO SERVE:

1. Developer Submits a request for ability to serve
  - a. Letter of request
  - b. A layout of subdivision and/or land development plan set, including phasing plan and site contours
  - c. Location map for site and directions to site
  - d. Completed meter and service sizing form or proposed water demands for each type of unit (gpm)
2. Veolia evaluates plan (Please allow 30 days for departmental review)
3. Veolia issues an Ability to Serve Letter: letter states conditions of service for proposed plan

### DESIGN:

1. Developer submits an electronic package to Veolia that includes **ALL** of the following: (all items must be included and submitted via link or email. We will no longer accept CD's or USBs)
  - a. A copy, in AutoCAD 2023 or earlier, and if required a survey of the off-site water main extension route including a Subsurface Utility Engineering (SUE) to locate vertically and horizontally all subsurface utilities,
  - b. A copy of the approved subdivision plan signature page fully executed by Municipal Officials,
  - c. A letter from the local municipality official approving all proposed fire hydrant locations and that the local municipality agrees to pay Veolia the monthly fee for any public fire hydrants,
  - d. A letter from the fire suppression system designer stating the size of the fire service if a fire suppression system is required,
  - e. An updated / completed Veolia meter and service sizing form for all facilities to be served, if required, and
  - f. A check for \$1,000 payable to Veolia Water Pennsylvania, which is applied to the cost of the water main design. The \$1,000 is non-refundable; however, it will be applied to the final cost of the project.
2. A final water design will be completed by Veolia and emailed to the developer, and will be the **ONLY** acceptable design used for bidding and construction of the proposed water network. Depending on the size of the project, a final design can take anywhere from 30-90 days to complete.
3. The Developer is responsible for all required permitting. Application packages shall be completed and submitted to Veolia for review and signature prior to submitting to approval agencies.
4. Developer selects a Veolia prequalified contractor, no exceptions and enters into a contract with contractor

### WATER MAIN EXTENSION AGREEMENT:

1. A Veolia Preliminary Cost Summary must be forwarded to Veolia Engineering.
2. The submitted Preliminary Cost Summary will be used to create a Water Main Extension Agreement for the proposed subdivision. The construction deposit costs include Veolia overheads, which are based on the total cost of the supply and installation of the proposed water network including water main, public fire hydrants, services from the water main to and including the curb stop, any other water facilities such as pump stations, tanks, PRV's etc. and inspection fees. The \$1,000 design deposit will be deducted from the total construction deposit. Veolia will send the prepared Agreement to the Developer for signature.
3. Developer returns the following to Veolia
  - a. Signed and Notarized Water Main Extension Agreement for a Non-Bona Fide Customer with the Preliminary Memorandum (2 copies)
  - b. A check for the total amount due
  - c. Permits (if applicable)
  - d. Fully executed Veolia Easement Agreement if any water facilities that will be owned by Veolia are being installed on private property.



4. Veolia returns the following to developer
  - a. Fully executed Water Main Extension Agreement for a Non-Bona Fide Customer, a Preliminary Memorandum and any required Easement Agreements signed and notarized by Veolia.

***At this point the pre-construction meeting can be scheduled by the Developer/Developer's Contractor.***

**CONSTRUCTION:**

1. Veolia schedules the preconstruction meeting with all appropriate representatives. The following is required for the meeting:
  - a. All material on site for inspection,
  - b. Verification that safety cards have been issued to all workers,
  - c. Copy of the latest edition of the Veolia Specification Manual on site,
  - d. Proof of Veolia required GPS equipment owned by Contractor and of Veolia approved training of GPS procedure and equipment operation,
  - e. All permits on site for inspection
  - f. Project schedule for review,
  - g. Plan for tie-ins, including scheduling and notification of tie-ins
2. Construction
  - a. Any tie-ins that need to be made will be scheduled in advance with Veolia Construction Coordinator and inspector. Customers must be notified 48 hours in advance.
  - b. Pressure tests will be performed by or under the direction of Veolia on all new main segments.
  - c. Any proposed field changes from the Veolia design must be approved by Veolia prior to work being done.

**CLOSE OUT:**

1. Upon completion of the project, the Developer must submit **ALL** of the following to Veolia in **ONE** package.
  - a. A Veolia Final Cost Summary Form
  - b. GPS data per current Veolia specifications
  - c. Record of Service spreadsheet (ROS) listing all details for each water service curb stop installed.
    - Must include USPS verified address for each lot
2. Veolia will inspect the project and develop a punch list of corrections to be completed prior to acceptance by Veolia. When the corrections are completed Veolia will re-inspect the project. If acceptable, Veolia will flush and test the system for bacteria contamination.
3. When the bacteria test is completed and prior to activation the Developer will provide the following to Veolia:
  - a. Maintenance Bond or letter of credit for a two (2) year period from the date of Veolia acceptance.
  - b. The Bill of Sale
4. Once all above are received, Veolia will activate the water main. There are no exceptions.

**MAINTENANCE BOND RELEASE:**

1. Veolia will conduct a final inspection of the project prior to the maintenance bond expiration date. If deficiencies are found a punch list of corrections that need completed will be developed and forwarded to the Developer. When the corrections are completed the project will be re-inspected by Veolia. When the project passes inspection the maintenance bond will be released to the developer.

**CONTACT:**

Angela Marcus  
Project Manager  
223-231-4984  
[Angela.Marcus@veolia.com](mailto:Angela.Marcus@veolia.com)

**Water Main Extension Agreement for a Non Bona Fide Customer**

C.E.A. No. \_\_\_\_\_

THIS AGREEMENT, made this \_\_\_\_\_ day of \_\_\_\_\_ (MONTH), (YEAR) by and between \_\_\_\_\_ (hereinafter called the "APPLICANT"), and SUEZ Water Pennsylvania Inc., a Pennsylvania Corporation, (hereinafter called The "COMPANY").

WHEREAS, the Applicant has requested the Company to extend its water mains to service areas or property, the dimensions and locations of which do fully and accurately appear on a certain plan attached to this agreement, made a part hereof and marked Exhibit "A"; and

WHEREAS, Company has determined that the potential revenues from such extension are such as to make it economically unfeasible for the Company to assume all of the initial cost; and

WHEREAS, the Applicant is willing and desires to assist in the installation of such extension and desires initially to bear the cost thereof, and the Company is willing to reimburse the Applicant for the cost of said extension to the extent and in the manner hereinafter set forth.

NOW, THEREFORE, IN CONSIDERATION OF THESE PRESENTS, the parties, intending to be legally bound hereby, mutually promise, covenant and agree as follows:

First: Prior to the execution of this Agreement, the Applicant hereby agrees to give to the Company, a written estimated cost for the water main extension including mains, services, public fire hydrants and other appurtenances. In addition the applicant hereby agrees to deposit with the Company an amount in cash equal to the company's construction overhead percentage rate of the total estimated cost of the water main extension and any additional facilities as well as the gross up effect of any taxes as may be levied on the installed facilities. The Applicant also hereby agrees that the installation and materials selected for the extension shall conform to the Company's specifications.

(1) The Estimated Cost shall be the estimated cost of the extension, including the mains, services, public fire hydrants and the estimated cost of any other facilities which the Company shall have decided are required to render adequate service. Costs for additional facilities, such as booster pumps, storage tanks and the like are Contributions in Aid of Construction which shall not be subject to refund.

(2) The Per Customer Refund Amount shall be for each additional permanent customer for whom a metered service connection shall be directly attached to applicant's main extension. Except that no refund shall be paid with respect to the attachment of an applicant if the applicant is a bona fide service applicant. The amount of the Per-customer Refund shall be determined as follows:

a. For attachments and connections made during the first three years following the date of the Agreement, the refunds will be equal to two (2) times the first year's calculated average annual revenue received from each residential customer, or the calculated annual revenue of that customer's class. The residential revenue shall be calculated on the average annual revenue for residential customers. Townhouses, apartments, and other multifamily customers may be refunded based on their first year's actual revenue or calculated based on their ERC.

SUEZ WATER PENNSYLVANIA INC.

b. For attachments made during the fourth and subsequent years following the date of the Agreement, the refund shall be equal to the first year's annual revenue of that customer as explained in (a.) above.

c. Prior to the execution of this Agreement, a Preliminary memorandum in the form attached to this agreement shall be prepared by the Applicant and signed by both parties showing the estimated cost and deposit required in accordance with the foregoing provisions. Upon completion of the installation of the extension, a Final Memorandum in the form attached to this agreement shall be prepared by the Applicant and signed by both parties showing the actual cost and the company's construction overhead costs on the same calculation as set forth above but by using the actual cost of the extension including the mains, services, fire hydrants and other appurtenances. If the required company's actual construction overhead costs shown to be due on the final memorandum differs from the estimated construction overhead costs shown on the preliminary memorandum, then the construction overhead costs will be adjusted. The Applicant will deposit any additional amount shown to be due, without interest within 30 days of notification of said adjustment, or the company will refund to the applicant any excess amount shown to have been deposited without interest, it being the intent of this agreement that the company's construction overhead costs shall be based on actual installation costs. Failure to make any such additional deposit may result in water service being refused or discontinued subject to Pennsylvania public utility commission regulations.

Second: The Applicant, upon receipt of the signed agreement and the Company approved estimated amount for the water main extension, will begin the installation of the water main extension, together with the necessary valves, service lines, fire hydrants, fittings and other appurtenances, all to be installed by a Contractor approved by the Company at locations and places more fully and completely described on attached Exhibit "A".

Third: The Company agrees that the above water main extension shall be as described in the attached Exhibit "A". The customer's service lines shall be of such sizes and in such locations as shall be agreed to by the Company and shall terminate immediately inside the curb line or at the limits of private rights-of-way.

Fourth: The Applicant covenants and agrees that the Applicant will indemnify the Company against any and all loss or damage which the Company may suffer as a result of any damage to its water mains, service lines, or fire hydrants by the Applicant, Applicant's employees, agents, servants, workmen or any contractors or subcontractors employed by the Applicant: (a) in the development of and construction upon the lots or properties abutting upon the streets or rights-of-way in which water mains are to be constructed pursuant to this agreement; or, (b) in the construction and surfacing of any of the streets in which water mains are to be installed pursuant to this agreement.

Fifth: The Applicant covenants and agrees that the Applicant will secure, at Applicant's sole cost and expense, the approval (if any be required) of the proper regulatory governmental body having jurisdiction thereof as to the established subgrades of the streets or rights-of-way in which water mains are to be installed pursuant to this agreement.

SUEZ WATER PENNSYLVANIA INC.

Sixth: Applicant will grant to the Company an irrevocable easement, at no cost to Company, for the maintenance, operation, repair and replacement of said main extension, services, fire hydrants and appurtenances within the limits of any existing or proposed street, avenue, roadway, private property or easement area, together with right of ingress and egress thereto, in a form satisfactory to the Company and duly executed and acknowledged in proper form for recording.

Seventh: It is further understood and agreed by and between the parties hereto that the Applicant's agreement to construct the said extension is subject to the Applicant obtaining all necessary consents, orders, permits and approvals of public officers or public bodies having jurisdiction over or lawful interest in any of the subject matters herein. In the event that the Applicant, after prompt application and diligent effort is unable to obtain any necessary consent, order, permit or approval as aforesaid, or in the event that the Applicant is enjoined or prevented by lawful action of any such public officer or official body from constructing the said extension, the Company's sole obligation will be to repay the Applicant the amount advanced for the Company's construction overhead costs less the cost which is incurred by the Company in conjunction with the main extension and appurtenances which are the subject of this Agreement.

Eighth: Applicant agrees that before the commencement of work, the Applicant will clearly mark upon the ground by means of stakes or in some other equally positive manner the exact lines and grades to which the street, highway, or land in which the said water pipes are to be laid is to be finally built and that he will grade the said street, highway, or land so that it will be at all points within less than one (1') foot of the above finished grades before the work of installing the said water pipes. The Company, however, shall not permit the Applicant's contractor to lay pipes according to lines or grades of which the Company does not approve. And it is agreed that any time, prior to the dedication and acceptance as a public street or highway by the governing body of any street or highway under which water mains are laid in conformity with this agreement it shall become necessary to change or move the said pipes or their appurtenances by reason of any change or alteration in the lines or grades of the street, highway, or land in which they are laid, then the expense of such change or moving of said pipes and their appurtenances, and any other expense incidental thereto, shall be borne by Applicant. And its also agreed that the applicant shall supply the company with an accurate "as built" set of plans for the construction project certified by a professional engineer or professional surveyor. The As-built plans must clearly show all fittings, valves, bends, hydrants, blow off assemblies, and service lines and include GPS coordinates as specified in the latest version of the Company's general information and standard specifications for the installation of water main and services. All appurtenances must be located using station numbers and or electronically coordinates referenced to a point established by a registered surveyor or engineer. Roadway stations are not acceptable for as built information. The final As-Built plan must be supplied to the Company in an acceptable format (currently AutoCad.dwg). A letter from the applicant's Engineer of Record certifying that the As- Built information is correct must accompany the electronic submission before the Company approves the As-Built.

Ninth: It is agreed by Applicant that the Applicant will not build at any time hereafter on, in, or over the said easement any structure, the construction or presence of which will endanger or render ineffective or difficult of access the water pipes or appurtenances of the Company, or lay other pipes or conduits within four (4') feet or ten (10) feet in the case of sewer mains measured horizontally, from the said water pipe except pipes crossing same at right angles in which latter case a minimum distance of eighteen (18") inches shall be maintained between the pipes. No excavation or blasting shall be carried on which in any way endangers the said water



SUEZ WATER PENNSYLVANIA INC.

---

pipes. Provided, however, that should the Applicant wish to do so it may, at its own expense, provide a new location acceptable to the Company for the said water pipes and the Applicant's contractor will then move said water pipes and appurtenances to said new location, and the whole cost of such moving and altering and any expense incident thereto, shall be borne by the Applicant.

Tenth: After acceptance by the Company, the water main extension as hereinbefore described with the necessary valves, connections, fittings and other appurtenances shall be the property of the Company and no charge or lien upon them shall arise as a result of the refund agreement set forth in Paragraph Twelfth hereof. The Company shall also have the right, by virtue of its ownership of said extensions, to make any additions to or extensions to said extension in its sole and absolute discretion.

Eleventh: Upon the completion of the aforesaid water main extension the Company, upon proper application shall provide water service to customers located along said extension in accordance with the rules and regulations of its published tariff.

Twelfth: The Company hereby agrees to refund to the Applicant during the period of ten (10) years from actual date of the agreement a per-customer refund amount for each additional Non Bona

Fide Customer for whom a service connection shall be directly attached to such main extension, as distinguished from main extensions thereof; provided however, that the total amount refunded shall not exceed the total actual cost, and that all or any part of the deposit not refunded within said 10 year period shall be considered a contribution to the Company.

Thirteenth: It is agreed between the parties hereto that the Applicant shall execute this agreement within thirty (30) days from the date upon which this agreement is transmitted to the Applicant and that upon the failure of the Applicant to execute within the time mentioned, this agreement shall be void at the option of the Company.

Fourteenth: This agreement shall be binding upon the heirs, executors, administrators, successors and assigns of the respective parties, however, it is understood and agreed between the parties hereto that the right to receive payment of refunds under the terms hereof shall be personal to the Applicant and the same shall not be assigned either as collateral security or otherwise.

IN WITNESS WHEREOF, the Applicant has hereunto set his hand and seal and the Company upon proper authority of its Board of Directors has caused this agreement to be executed by its Vice President, all on the day and year first above written.

ATTEST:

APPLICANT:

---

ATTEST:

---

SUEZ WATER PENNSYLVANIA INC.:

---

Vice President

SUEZ WATER PENNSYLVANIA INC.

---

**PRELIMINARY MEMORANDUM**

This Preliminary Memorandum is executed by the parties hereto under and pursuant to the provisions of Paragraph First of a certain agreement in writing between the parties entered into on the    day of (month), (year) for the installation by the Applicant of a certain water main(s) therein described. It is, therefore, agreed and stipulated:

	Refundable	Non-Refundable
(a) Estimated Cost Main(s)	\$ _____	\$ _____
(b) Estimated Cost of Fire Hydrants	\$ _____	\$ _____
(c) Estimated Cost of Services	\$ _____	\$ _____
(d) Estimated Cost of Other Facilities	\$ _____	\$ _____
(e) Subtotal	\$ _____	\$ _____
(f) Estimated Company Construction Overhead	\$ _____	\$ _____
(g) Estimated Gross Up Taxes	\$ _____	\$ _____
(h) Total	\$ _____	\$ _____

This Preliminary Memorandum shall be attached to the original agreement in accordance with the provisions of Paragraph First thereof.

Dated:

WITNESS:

SUEZ WATER PENNSYLVANIA INC.:

\_\_\_\_\_

Vice President

WITNESS:

APPLICANT:

\_\_\_\_\_



SUEZ WATER PENNSYLVANIA INC.

---

**FINAL MEMORANDUM**

This Final Memorandum is executed by the parties hereto under and pursuant to the provisions of Paragraph First of a certain agreement in writing between the parties entered into on the \_\_ day of (month), (year) for the installation by the Applicant of a certain water main(s) therein described. It is, therefore, agreed and stipulated:

	Refundable	Non-Refundable
(a) Actual Cost Main(s)	\$ _____	\$ _____
(b) Actual Cost of Fire Hydrants	\$ _____	\$ _____
(c) Actual Cost of Services	\$ _____	\$ _____
(d) Actual Cost of Other Facilities	\$ _____	\$ _____
(e) Subtotal Actual Costs	\$ _____	\$ _____
(f) Actual Company Construction Overhead	\$ _____	\$ _____
(g) Actual Estimated Gross Up Taxes	\$ _____	\$ _____
(h) Total	\$ _____	\$ _____

This Final Memorandum shall be attached to the original agreement in accordance with the provisions of Paragraph First thereof.

Dated:

WITNESS:

SUEZ WATER PENNSYLVANIA INC.:

\_\_\_\_\_  
Vice President

WITNESS:

APPLICANT:



## EXAMPLE WATER SERVICE & METER SIZING FORM



Water Service and Meter Sizing Customer Information					
<i>Customer Name</i>				<i>Phone</i>	
<i>Company</i>				<i>Fax</i>	
<i>Address</i>				<i>Cell</i>	
<i>City</i>		<i>State</i>		<i>Zip Code</i>	
<i>Project Name and Location</i>					
<b>This is <u>not</u> an application for service. Customer must call VEOLIA Customer Service (888) 299-8972, (717) 920-3663 to complete an application</b>					
Fixture		Total Number of Fixtures (New and Existing)			
Bathtub					
Bedpan Washers					
Combination Sink and Tray					
Dental Unit					
Dental Lavatory					
Drinking Fountain	Cooler				
	Public				
Kitchen Sink	1/2" Connection				
	3/4" Connection				
Lavatory Sinks	3/8" Connection				
	1/2" Connection				
Laundry Tray	1/2" Connection				
	3/4" Connection				
Shower Head	(shower only)				
Service Sink	1/2" Connection				
	3/4" Connection				
Urinal	Pedestal Flush Valve				
	Wall Flush Valve				
	Trough (2 ft. unit)				
Wash Sink	(each set of faucets)				
Toilets	Flush Valve				
	Tank Type				
Dishwasher	1/2" Connection				
	3/4" Connection				
Washing Machine	1/2" Connection				
	3/4" Connection				
	1" Connection				
Hose Bibb (wash down)	1/2" Connection				
	5/8" Connection				
Misc. Outlet (Not listed above)	3/4" Connection				
Elevation in Feet - Height of Highest Fixture from Ground Level					
Total Length of Service - Water main to structure					
Is fire service needed? Yes or No					
Type of Service: Check All That Apply					
Residential		Shopping Center			
Apartment		Restaurant			
Motel		Public School			
Condominium		Public Building			
Trailer Park		Hospital			
Hotel		Irrigation			

## VEOLIA APPROVED CONTRACTOR LIST

**VEOLIA Water Pennsylvania, Inc.  
2024 Harrisburg/Mechanicsburg  
Pre-Qualified Water Main  
Construction Contractors**

**B.R. Kreider & Son, Inc.**  
Roger Armstrong  
63 Kreider Lane  
Manheim, PA 17545  
Ph: (717) 898-7651  
[rarmstrong@brkreider.com](mailto:rarmstrong@brkreider.com)

**CH+N Construction**  
Matt Eshelman  
322 North Arch Street  
Lancaster, PA 17603  
Ph: (717) 560-1400  
[m.eshelman@chnsite.com](mailto:m.eshelman@chnsite.com)

**Concept Excavating Inc.**  
Jim Martin/ Reid Martin  
503 Alexander Drive  
Ephrata, PA 17522  
Ph: (717) 733-3545/(717)490-9057  
[Jim@conceptexcavating.net](mailto:Jim@conceptexcavating.net)  
[Reid@conceptexcavating.net](mailto:Reid@conceptexcavating.net)  
[office@conceptexcavating.net](mailto:office@conceptexcavating.net)

**DSW Services**  
David Watchman  
PO 7309 Stoneridge Circle  
Harrisburg, PA 17112  
Ph: (717) 554-0533  
[dsw.services@aol.com](mailto:dsw.services@aol.com)

**Ebersole Excavating, Inc.**  
Jeff Ebersole  
PO Box 418  
Hershey, PA 17033  
Ph: (717) 367-3597  
[JeffEbersole@comcast.net](mailto:JeffEbersole@comcast.net)

**E.K. Service, Inc.**  
Ken Beinhower, Sr.  
260 Old York Road  
New Cumberland, PA 17070  
Ph: (717) 774-7913/ 554-9883  
[Kbeinhower@EKServiceinc.com](mailto:Kbeinhower@EKServiceinc.com)

**Hershey Excavating LLC**  
Shawn Hershey  
1943 Old Line Road  
Manheim, PA 17545  
Ph: (717) 664-0084  
[shawn@hersheyexcavating.com](mailto:shawn@hersheyexcavating.com)

**J. F. Kiely Construction Co.**  
Douglas Hulse  
700 McClellan Street  
Long Branch, NJ 07740  
Ph: (732) 403-8500 x209  
Cell: (732) 677-8589  
[www.jfkielyservice.com](http://www.jfkielyservice.com) [dhulse@jfkiely.com](mailto:dhulse@jfkiely.com)

**J. L. B. Construction, Inc.**  
Jeffrey Bonawitz, Pres.  
PO Box 429  
Grantville, PA 17028  
Ph: (717) 533-3373  
[JLBJeff@comcast.net](mailto:JLBJeff@comcast.net)

**John W. Gleim, Inc.**  
Donald Smith  
625 Hamilton Street  
Carlisle, PA 17013  
Ph: (717) 243-7160  
[dsmith2@jwgleim.com](mailto:dsmith2@jwgleim.com)

**JVH Excavating, Inc.**  
Scott Gergal  
700 Ayers Avenue  
Lemoyne, PA 17043  
Ph: (717) 737-4820  
[jvhexcavating@pa.net](mailto:jvhexcavating@pa.net)  
[scott@JVHexcavating.com](mailto:scott@JVHexcavating.com)

**Keystone Contracting, Inc.**  
Rick Jones  
4 South Market Street  
Duncannon, PA 17020  
Ph: (717) 834-9900/(717)443-9738  
[KCIfrisch@aol.com](mailto:KCIfrisch@aol.com)

**Kinsley Construction**  
Brian Babula  
2700 Water Street  
York, PA 17403  
Ph: (717) 741-3841/(717)324-2010  
[gmyers@kinsleyconstruction.com](mailto:gmyers@kinsleyconstruction.com)

**Leon E. Wintermyer, Inc.**  
Ed Fessler  
220 Yocumtown Road  
Etters, PA 17319  
Ph: (717) 685-6019  
[efessler@lewinc.com](mailto:efessler@lewinc.com)

## Pre-Qualified Contractors Continued

### **Main Line Excavating, Inc.**

Wayne Stevens  
2325 Paxton Church Road  
Harrisburg, PA 17110  
Telephone No. (717) 909-5578  
[wstevens@mlexc.com](mailto:wstevens@mlexc.com)

### **R.L. Livingston, Inc.**

Rick Livingston  
15 Industrial Drive  
Manchester, PA 17345  
Ph: (717) 384-6782  
[RL@RLLivingston.com](mailto:RL@RLLivingston.com)

### **Robert-Thomas Construction, Inc.**

Tom Mellott  
P. O. Box 413  
Hershey, PA 17033-0413  
Ph: (717) 664-4094  
[TKM17112@aol.com](mailto:TKM17112@aol.com)

### **Rogele, Inc.**

Dennis McClure  
1025 S. 21<sup>st</sup> Street  
P. O. Box 1757  
Harrisburg, PA 17105-1757  
Ph: (717) 564-0478  
[dmcclure@rogele.com](mailto:dmcclure@rogele.com)

### **T & D Excavating**

David Wolgemuth  
1940 E. Mount Hope Road  
Manheim, PA 17545  
Ph: (717) 665-6776  
[Tdexec@pdexc.com](mailto:Tdexec@pdexc.com)

### **York Excavating Co. LLC**

Eric Yun  
3180 East Prospect Road  
York, PA 17406  
Ph: (717) 755-0607  
[eric@yecoi.com](mailto:eric@yecoi.com)

**Veolia Water Pennsylvania  
2024 Bloomsburg/Dallas  
Pre-Qualified Water Main  
Construction Contractors**

**Fehlinger Construction Group**

Herb Fehlinger

106 S. Lehigh Street, Suite 203

Shavertown, PA 18708

Ph: (570) 696-2792

[hfehlinger@fehlingerconstruction.com](mailto:hfehlinger@fehlingerconstruction.com)

[tquinnan@fehlingerconstruction.com](mailto:tquinnan@fehlingerconstruction.com)

**G & M Crawford, Inc.**

Steven W. Crawford, President

276 Mellick Hollow Road

Bloomsburg, PA 17815

Ph: (570) 784-9313

[jim@gmcrawford.com](mailto:jim@gmcrawford.com)

**James T. O'Hara, Inc.**

Bob Opalka

205 Old School House Road

Covington Township, PA 18444

Ph: (570) 842-2140

[jtobids@gmail.com](mailto:jtobids@gmail.com)

**J. F. Kiely Construction Co.**

Douglas Hulse

1 Radar Way

Tinton Falls, NJ 17724

Ph: (732) 403-8500 x209

Cell: (732) 677-8589

[www.jfkielyservice.com](http://www.jfkielyservice.com) [dhulse@jfkiely.com](mailto:dhulse@jfkiely.com)

**Pioneer Construction Co., Inc.**

Michael Cavage/ Steve Durhammer

3298 Lake Ariel Highway

Honesdale, PA 18431

Ph: (717) 479-1197

[pcci@ptd.net](mailto:pcci@ptd.net)

**Sikora Brothers Paving, Inc.**

Chase Kelch

10 Nevel Hollow Road

Hunlock Creek, PA 18621

Ph: (570) 256-3708

[ckelch32@gmail.com](mailto:ckelch32@gmail.com)

**Sokol, Inc.**

Paul Sokol

P.O. Box 366

128 Harris Road

Bloomsburg, PA 17815

Ph: (570) 784-4411

[Paul@sokolinc.com](mailto:Paul@sokolinc.com)